

HALE

6/1/99

FOAM MASTER

ROTARY GEAR PUMP ELECTRONIC FOAM PROPORTIONING SYSTEM

DESCRIPTION, INSTALLATION AND OPERATION MANUAL

NOTICE: This manual is divided into four sections for clarity and ease of use. **Section I: DESCRIPTION;** Provides an introduction to the Hale FoamMaster System along with guidelines for designing and ordering a complete system. **Section II: INSTALLATION;** Provides information to assist the OEM with installation and initial set-up of Hale FoamMaster systems on an apparatus. **Section III: SET-UP AND CALIBRATION;** Is used by the installer and end user for start-up and calibration of the Hale FoamMaster system. **Section IV: OPERATION;** Is primarily used by the apparatus user for proper operation and maintenance of the Hale FoamMaster system. Each manual section can be a stand alone section or can be used in conjunction with each other.

Hale FoamMaster System Serial Number: _____

All Hale products are quality components: ruggedly designed, accurately machined, precision inspected, carefully assembled and thoroughly tested. In order to maintain the high quality of your unit, and to keep it in a ready condition, it is important to follow the instructions on care and operation. Proper use and good preventive maintenance will lengthen the life of your unit. ALWAYS INCLUDE THE UNIT SERIAL NUMBER IN CORRESPONDENCE.

HALE PRODUCTS, INC. • A Unit of IDEX Corporation • 700 Spring Mill Avenue • Conshohocken, PA 19428 • TEL: 610-825-6300 • FAX: 610-825-6440

MANUAL P/N 029-0020-35-0, REV E, © 1999 HALE PRODUCTS, INC., PRINTED IN U.S.A.



Hale Products cannot assume responsibility for product failure resulting from improper maintenance or operation. Hale Products is responsible only to the limits stated in the product warranty. Product specifications contained in this material are subject to change without notice.



TABLE OF CONTENTS

Chapter Title	Page
SECTION I: DESCRIPTION	
SAFETY	I-1
SYSTEM DESCRIPTION	I-3
Hale FoamMaster SYSTEM SPECIFICATIONS	I-6
SYSTEM CONFIGURATION	I-8
SYSTEM DIAGRAMS	I-17
SECTION II: INSTALLATION	
SAFETY	II-1
APPARATUS INSTALLATION PLANNING	II-3
INSTALLER SUPPLIED COMPONENT RECOMMENDATIONS	II-5
FOAM PUMP MOUNTING	II-9
PLUMBING COMPONENT INSTALLATION	II-12
SYSTEM PLUMBING DIAGRAMS	II-24
ELECTRICAL INSTALLATION	II-32
Hale FoamMaster SYSTEM ELECTRICAL DIAGRAMS	II-42
START-UP CHECKLIST	II-44
SYSTEM INSTALLER START-UP	II-45
SECTION III: SET-UP AND CALIBRATION	
SAFETY	III-1
INSTALLATION AND DELIVERY CHECKLIST	III-3
INITIAL END USER SET-UP	III-4
USER CALIBRATION	III-6
SECTION IV: SYSTEM OPERATION	
SAFETY	IV-1
OPERATING INSTRUCTIONS	IV-3
Normal Operation Summary	IV-8
Simulated Flow Operation	IV-10
Tank Selection With Dual Tank System	IV-12
Flushing Hale FoamMaster	IV-13
Operation with Remote ON/OFF Switch	IV-14
Priming The Foam Pump When Foam Tank Has Run Dry	IV-14
MAINTENANCE	IV-15
TROUBLESHOOTING	IV-16
PARTS IDENTIFICATION	IV-22
WARRANTY	IV-29

System installer must provide two copies of this Hale FoamMaster System Description, Installation and Operation Manual to the end user of the equipment. If additional manuals are required, contact Hale Products Inc. Communications Department at (610) 825-6300.
Ask for Manual P/N 029-0020-35-0.

HALE

FOAM MASTER

ROTARY GEAR PUMP ELECTRONIC FOAM PROPORTIONING SYSTEM

DESCRIPTION, INSTALLATION AND OPERATION
MANUAL

SECTION I DESCRIPTION

NOTICE: This manual section provides a general description of the Hale Foammaster System along with guidelines for designing and ordering a complete system. This manual section can be used as a stand alone section or in conjunction with other sections of the complete manual.

HALE PRODUCTS, INC. • A Unit of IDEX Corporation • 700 Spring Mill Avenue • Conshohocken, PA 19428 • TEL: 610-825-6300 • FAX: 610-825-6440

IDEX
IDEX CORPORATION

Hale Products cannot assume responsibility for product failure resulting from improper maintenance or operation. Hale Products is responsible only to the limits stated in the product warranty. Product specifications contained in this material are subject to change without notice.

HALE

GODIVA

HK



SAFETY

Hale FoamMaster systems are designed to provide reliable and safe foam concentrate injection. Before installing or operating a Hale FoamMaster system read all safety precautions and follow carefully to ensure proper installation and personnel safety.

WARNINGS

1. Do not permanently remove or alter any guard or insulating devices or attempt to operate the system when these guards are temporarily removed.
2. To prevent electrical shock always disconnect the primary power source before attempting to service any part of the Hale FoamMaster system.
3. All electrical systems have the potential to cause sparks during service. Take care to eliminate explosive or hazardous environments during service/repair.
4. To prevent system damage or electrical shock the main power supply wire will be the last connection made to the Hale FoamMaster distribution box.
5. Release all pressure then drain all concentrate and water from the system before servicing any of its component parts.
6. Rotating drive line components can cause injury. When working on components of the Hale FoamMaster system be careful of rotating components.
4. Hale FoamMaster systems are designed for use on negative ground direct current electrical systems only.
5. Do not mount radio transmitter or transmitter cables in direct or close contact with the Hale FoamMaster unit.
6. Before connecting the cordsets inspect the seal washer in the female connector. If the seal washer is missing or damaged, water can enter the connector causing corrosion of the pins and terminals resulting in possible system failure.
7. Always disconnect the power cable, ground straps, electrical wires and control cables from the control unit or other Hale FoamMaster equipment before electric arc welding at any point on the apparatus. Failure to do so could result in a power surge through the unit that could cause irreparable damage.
8. **DO NOT** connect the main power lead to small leads that are supplying some other device such as a light bar or siren. The Hale FoamMaster Model 3.3 and Model 5.0 require 60 AMP minimum current. The Hale FoamMaster Model 3.0 requires 40 AMP minimum current. Use correct gauge wire as specified.

CAUTIONS

1. Foam tank low level sensors must be utilized to protect the Hale FoamMaster from dry running. Failure to use low level sensors with the Hale FoamMaster system will void warranty.
2. Do not operate system at pressures higher than the maximum rated pressure.
3. Use only pipe, hose, and fittings from the foam pump outlet to the injector fitting, which are rated at or above the maximum pressure rating at which the water pump system operates.
9. When operating the Hale FoamMaster in Simulated Flow mode an outlet for the foam concentrate must be provided to prevent excessive pressure buildup in discharge piping or hoses.
10. Unless engaged in Class B foam operations, the Hale FoamMaster ADT toggle switch or Hale FoamMaster MDT II selector handle must be in the **TANK A** position. If the toggle switch or selector handle is in the **FLUSH** position when the Hale FoamMaster foam pump is started the foam pump will only run for 20 seconds and shut down.

11. Make sure the foam tank and foam concentrate suction hoses are clean before making final connection to foam pump. If necessary flush tank and hoses prior to making connection.

NOTES

1. Check all hoses for weak or worn conditions after each use. Ensure that all connections and fittings are tight and secure.
2. Ensure that the electrical source of power for the unit is a negative ground DC system, of correct input voltage, with a reserve minimum current available to drive Hale FoamMaster system.
3. The in-line strainer/valve assembly is a low pressure device and WILL NOT withstand flushing water pressure. When installing the in-line strainer in systems equipped with Hale MDT II or Hale MST make sure the in-line strainer/valve assembly is in the hose on the inlet side of the valve. If the strainer will be subject to flushing water pressure, use Hale FS series strainers.
4. When determining the location of Hale FoamMaster components keep in mind piping runs, cable routing and other interferences that will hinder or interfere with proper system performance.
5. The Hale HPF flowsensor is assembled and tested at the factory. Removal of the flow sensor from the tee is not necessary or recommended for installation in the system.
6. Always position the check valve/injector fitting at a horizontal or higher angle to allow water to drain away from the fitting. This will avoid sediment deposits or the formation of an ice plug.
7. The cordsets provided with each Hale FoamMaster system are 100% electrically shielded assemblies. Never attempt to shorten or lengthen the molded cables. If necessary order longer or shorter cordsets from Hale Products to suit the particular installation.
8. The cordsets provided with each Hale FoamMaster system are indexed so they only go in the correct receptacle and they can only go in one way. When making cordset connections DO NOT force mismatched connections as damage can result in improper system operation.
9. The system can only perform when the electrical connections are sound, so make sure each one is correct.
10. The cables shipped with each Hale FoamMaster system are 100% tested at the factory with that unit. Improper handling and forcing connections can damage these cables which could result in other system damage.
11. There are no user servicable parts inside Hale FoamMaster system electrical/electronic components. Opening of these components (distribution box, control unit, foam discharge multiplexing display unit) will void warranty.
12. Use mounting hardware that is compatible with all foam concentrates to be used in the system. Use washers, lockwashers and capscrews made of brass or 300 series stainless steel.
13. When making wire connections make sure they are properly insulated and sealed using an adhesive filled heat shrink tubing.
14. Before running wires from the low tank switches to the A-B switch box make sure the wire from Tank A is identified and properly labeled.
15. **ALWAYS** connect the primary positive power lead from the terminal block to the master switch terminal or the positive battery terminal using minimum 4 AWG type SGX (SAE J1127) chemical resistant battery cable and protect with wire loom.
16. Prevent corrosion of power and ground connections by sealing these connections with silicone sealant provided.
17. Prevent possible short circuit by using the rubber boot provided to insulate the primary power connection at the Hale FoamMaster distribution box.

SYSTEM DESCRIPTION

Hale FoamMaster foam proportioning systems are completely engineered, factory matched foam proportioning systems that provide reliable, consistent foam concentrate injection for Class A and Class B foam operations. Hale FoamMaster systems accurately deliver from 0.1% to 10.0% foam concentrate through a check valve/injector fitting directly into the water discharge stream. It is then fed as foam solution into a standard fog nozzle, an air aspirated nozzle, or CAFS equipment, through the apparatus discharge piping. A properly configured and installed Hale FoamMaster system with Hale recommended components virtually eliminates contamination of the booster tank, fire pump and relief valve with foam concentrate.

The heart of the Hale FoamMaster system is an electric motor driven rotary gear pump. The pump is constructed of bronze and stainless steel and is compatible with almost all foam concentrates. The pump is close coupled to the electric motor thereby eliminating maintenance of an oil filled gearbox. An internal relief valve, constructed of stainless steel, protects the foam pump and foam concentrate discharge hoses from overpressurization and damage.

The control unit, mounted on the operator panel, is the single control point for the Hale FoamMaster system. Depressing the **ON** button starts foam concentrate injection. A super brite digital LED display shows the water flow rate, total water flowed, foam concentrate injection percentage and total foam concentrate used depending on the display mode selected. A bargraph on the control unit provides indication of the approximate system capacity being used. Adjustment of foam concentrate injection rate can be accomplished by pushing a

button while the system is operating. The control unit display also warns the operator when errors or abnormal operations occur in the system.

Foam concentrate injection rate is controlled by an Intel® computer chip in the control unit for accurate, repeatable, reliable foam concentrate injection. A water flowsensor constantly monitors water flow through the discharge piping. The information from the flowsensor is provided to the control unit by a shielded cable. When the Hale FoamMaster system is activated at the control unit a signal is sent from the control unit through the shielded control cable to the distribution box to begin foam concentrate injection. The distribution box then provides power to the electric motor. As the motor rotates the pump, foam concentrate flows through the foam pump discharge to the one piece check valve/injector fitting into the water discharge stream.

A feedback sensor in the foam pump body measures foam concentrate flow. The water flow rate and foam concentrate flow rate are constantly compared by the computer chip in the control unit. The motor speed is constantly adjusted to maintain the operator selected foam concentrate injection rate. Since the system is flow based, injection rate remains constant regardless of changes in system pressure or the number of discharges open.

There are three models of Hale FoamMaster systems covered by this manual. The Hale FoamMaster Model 3.0, Model 3.3 and Model 5.0. The maximum rated foam concentrate flow in gallons per minute is denoted by the model number. Table 1 shows system capacities at various foam concentrate injection rates for the different Hale FoamMaster Models.

Table 1. Maximum Foam Solution Flows

FOAM CONCENTRATE (%)	WATER FLOW					
	MODEL 3.0		MODEL 3.3		MODEL 5.0	
	GPM	LPM	GPM	LPM	GPM	LPM
0.1	3000	11355	3300	12491	5000	18925
0.2	1500	5678	1650	6245	2500	9463
0.3	1000	3785	1100	4164	1667	6310
0.5	600	2271	660	2498	1000	3785
1	300	1136	330	1249	500	1893
3	100	379	110	416	167	632
6	50	189	55	208	83	314

Hale FoamMaster systems can be configured to operate with single or dual foam concentrate tanks. Examples of the various Hale FoamMaster system configurations are shown in figures 1-1 through 1-6 at the end of this section.

The available Air Dual Tank (ADT) valve for the Hale FoamMaster system is an air operated foam tank selector valve that provides selection of foam concentrate dependent on fire ground operational demands. The ADT is an integral part of the foam pump and provides an electrical interlock for the low tank level sensors and concentrate injection rate. A panel mounted selector toggle switch with indicator lights controls foam concentrate tank selection and shows which foam concentrate tank is in use.

The Manual Dual Tank (MDT II) selector valve is available for the Hale FoamMaster systems with dual tanks. The MDT II is a panel mounted manually operated selector that provides selection of foam concentrate dependent on fire ground operational demands. The MDT II also provides an electrical interlock for the low tank level sensors and concentrate injection rate. It should be noted that the MDT II is not suitable for top mount operator panel installations and some side operator panels due to gravity feed requirements of foam concentrate.

Selection of the desired foam concentrate tank with the ADT panel mounted toggle switch or MDT II selector will automatically change the foam concentrate injection rate to the preset default rate for the selected foam tank. No further operator intervention is required.

Single tank Hale FoamMaster systems can be configured with a Manual Single Tank (MST) selector which provides a flush function connection to the Hale FoamMaster electronic controls.

The ADT, MDT II and MST all provide the check valves and connection points to provide foam pump flushing capabilities.

Strainers available for Hale FoamMaster systems protect the foam pump from debris that might accumulate in the foam concentrate tank. The standard in-line strainer/valve assembly has a composite non-metallic housing with stainless steel mesh strainer element. It is provided with a service shutoff valve, mounting bracket and fittings for connection of either 1 inch (25 mm) ID or ¾ inch (19 mm) ID foam concentrate suction hose. The in-line strainer/valve assembly is suitable for use with both Class A and Class B foam concentrates. The in-line strainer/valve assembly is designed for installations where the strainer is mounted in the foam pump suction line and IS NOT subject to flushing water pressure.

Hale FS series strainers are panel mounted strainers with a 500 PSIG (34 BAR) pressure rating suitable for use where flushing water pressure will go through the strainer. The FS15 strainer has ¾ inch NPT connection ports and a 1-½ inch NST cap and is suitable for use with Class A and low viscosity Class B foam concentrates. The FS25 strainer has 1 inch NPT connection ports and a 2-½ inch NST cap and is suitable for use with both Class A and Class B foam concentrates.

All Hale FoamMaster systems require at least one flowsensor for operation. Some systems may be designed to operate using multiple flowsensors for a wide range of discharge flows. When 2 or more flowsensors (up to eight) are installed on an apparatus equipped with a Hale FoamMaster system, Foam Discharge Multiplexing Display Units must be installed. Each multiplexing unit receives a signal from an individual flowsensor and provides a constant digital readout of flow in the monitored discharge. The multiplexing units are interconnected and the final unit is connected to the control unit. The control unit provides a digital readout of the total flow in all flowsensor monitored discharges. Additionally, a pressure transducer mounted in the discharge piping provides a signal that is shown on the multiplexing unit bargraph as the discharge pressure. A push button on the multiplexing unit gives a digital readout of the discharge pressure. The multiplexing unit is used on the operator panel instead of analog line pressure gauges.

Ordering of Hale FoamMaster systems is simple. Using the current Hale FoamMaster System Price List and Order Form helps ensure a complete matched system is provided to the end user. Use the following procedure when ordering a Hale FoamMaster system:

1. Determine the type of foam concentrate to be used in the system and ensure system compatibility by referring to the Hale FoamMaster Concentrate Compatibility list (Bulletin #650).
2. Determine the Hale FoamMaster system desired (**Model 5.0**, Model 3.3 or Model 3.0; **12 VDC** or 24 VDC motor; control

3. Determine tank selector desired based on the number of foam concentrate tanks installed (**ADT** or MDT II for dual tank systems; MST or No Selector for single tank systems).
4. Determine strainers desired (**In-line Strainer/Valve Assembly**, FS 15 Strainer or FS 25 Strainer).
5. Determine the low tank level sensors desired (**Side Mount**, Bottom Mount or Top Mount Assembly).
6. Determine the size of flowsensor desired based on minimum and maximum discharge flow (HPF40, HPF30, **HPF25**, HPF20 or HPF15; flowsensor cable length, **16.5 feet** or 6.5 feet).
7. If multiple flowsensors are required determine the number of foam discharge multiplexing display units to order.
8. Determine additional Hale components that enhance system operation and ease installation (Waterway Check Valves, Manifolds, Flanges, etc.).

A complete Hale FoamMaster system requires steps 1 through 6 above. Components shown in **Bold** type above represent the best value performance system. System components are shown in the following system configuration section. All components listed have been engineered and tested with Hale FoamMaster systems to provide optimum system performance. Using the information provided in this manual section and the detailed ordering procedures on the option order form ensures a complete Hale FoamMaster system is ordered thus eliminating delays caused by missing components.

HALE FOAMMASTER SYSTEM SPECIFICATIONS

Foam Pump	Rotary Gear Positive Displacement
Rated Foam Concentrate Output	
Model 3.0	3.0 GPM (11 LPM)
Model 3.3	3.3 GPM (12 LPM)
Model 5.0	5.0 GPM (19 LPM)
Maximum System Operating Pressure	
Model 3.0	250 PSI (17 BAR)
Model 3.3	400 PSI (28 BAR)
Model 5.0	250 PSI (17 BAR)
Maximum Operating Temperature	160°F (71 C)
Pump Motor	
Model 3.0	½ HP (0.4 kW), 12 VDC (Standard) ½ HP (0.4 kW), 24 VDC (Optional)
Model 3.3 and Model 5.0	¾ HP (0.5 kW), 12 VDC (Standard) ¾ HP (0.5 kW), 24 VDC (Optional)
Operating Ampere Draw	30 AMPS
Maximum Ampere Draw	
Model 3.0	40 AMPS
Model 3.3 and Model 5.0	60 AMPS

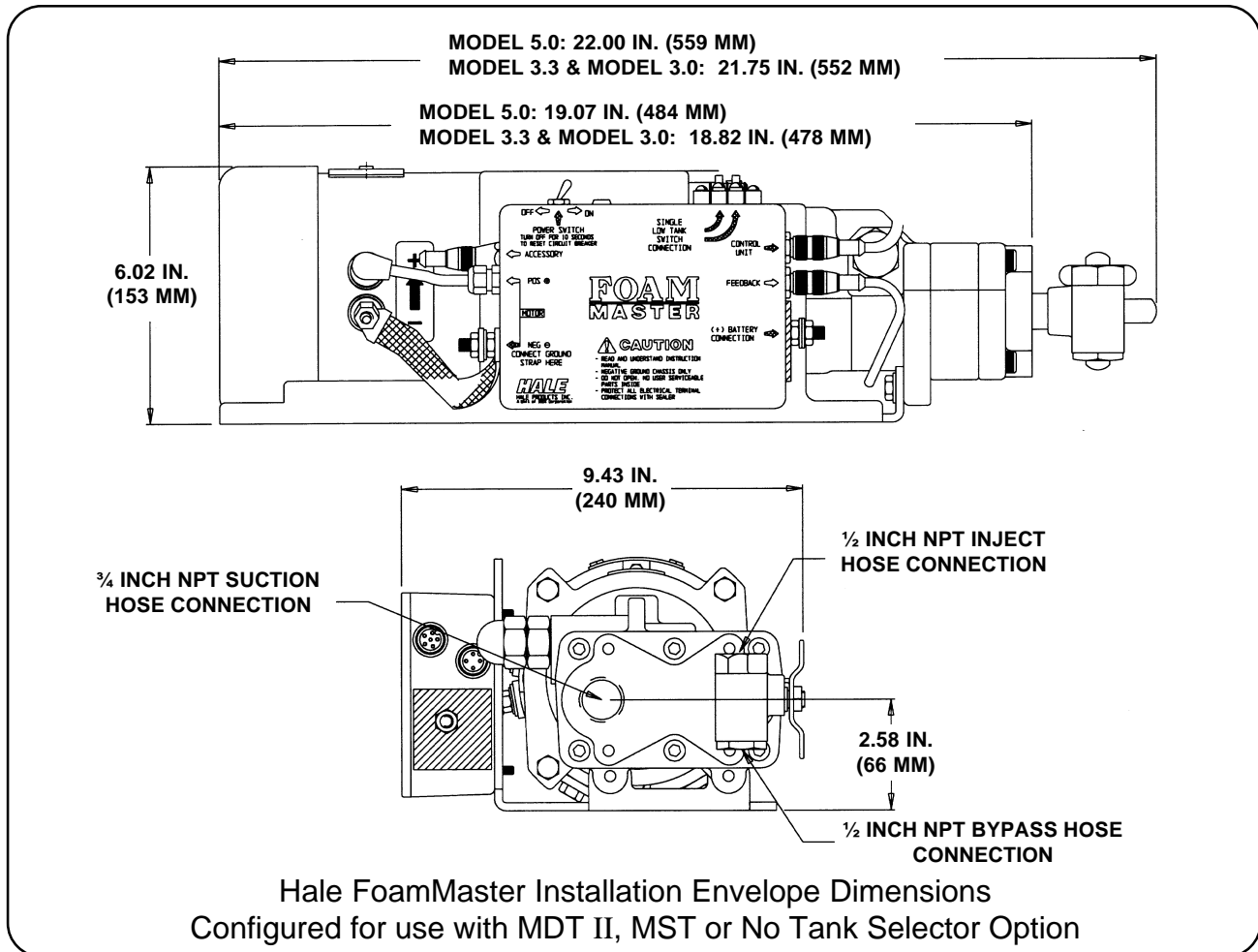

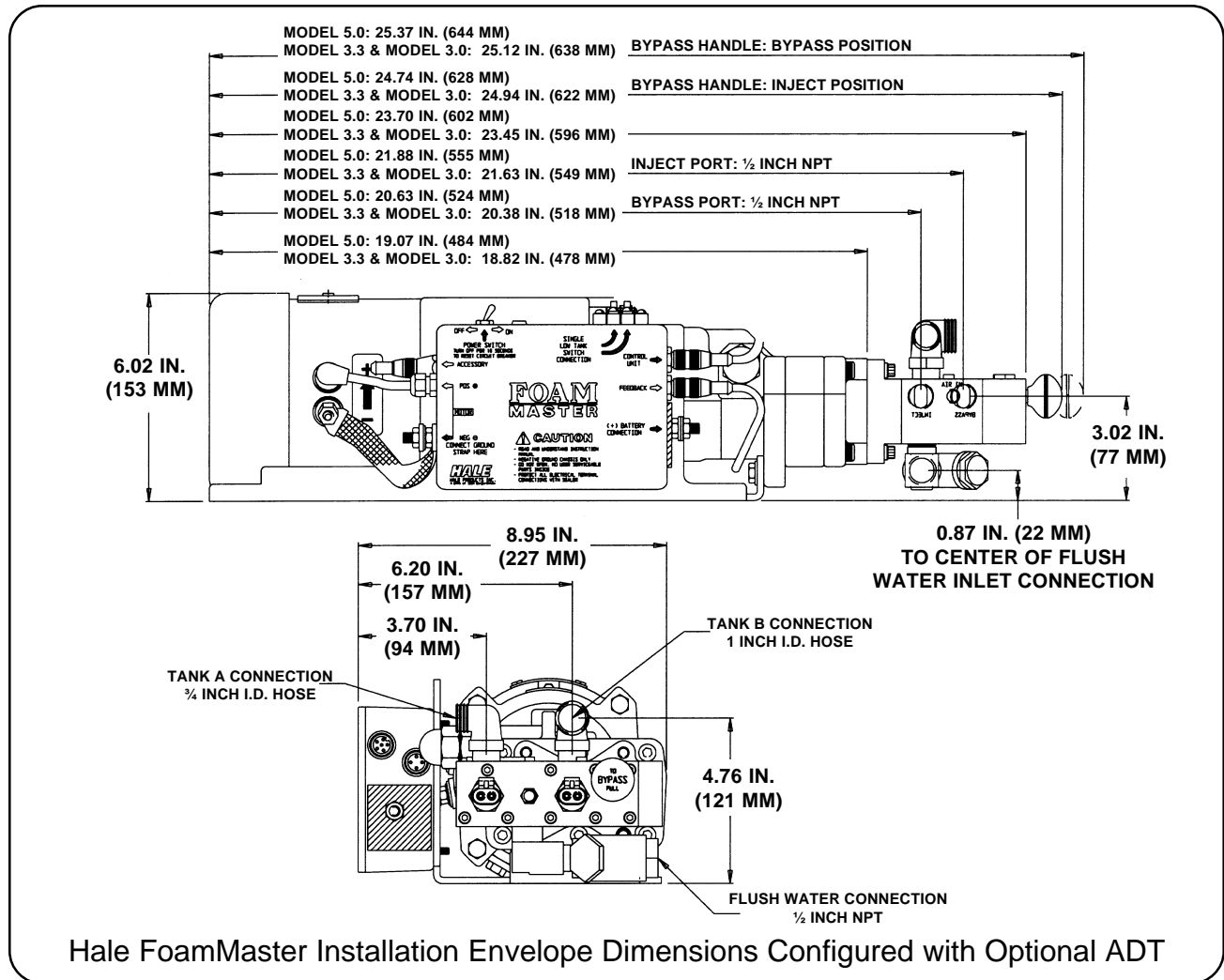

SYSTEM CONFIGURATION

Hale FoamMaster System Model

(Model 3.0, Model 3.3 or Model 5.0)

All Hale FoamMaster systems include: Foam Pump/Motor Assembly, Control Unit, Control Cable and Check Valve/Injector Fitting

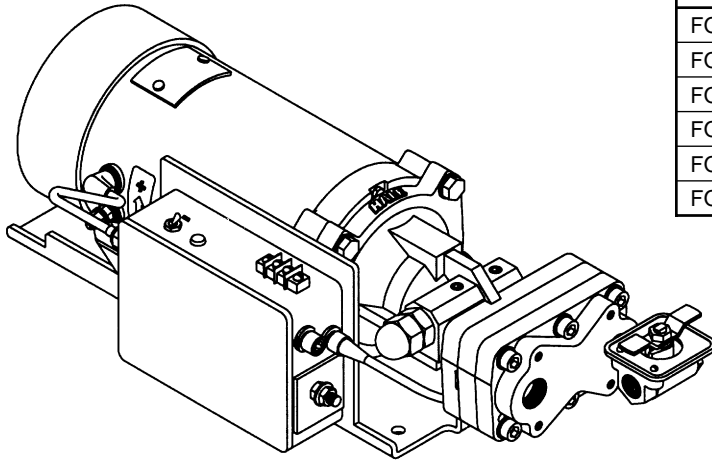

FOAMMASTER MODEL	PART NUMBER
FOAMMASTER 5.0 W/12 VDC MOTOR	501-3130-15-0
FOAMMASTER 5.0 W/24 VDC MOTOR	501-3130-24-0
FOAMMASTER 3.3 W/12 VDC MOTOR	501-3120-15-0
FOAMMASTER 3.3 W/24 VDC MOTOR	501-3120-24-0
FOAMMASTER 3.0 W/12 VDC MOTOR	501-3110-15-0
FOAMMASTER 3.0 W/24 VDC MOTOR	501-3110-24-0

Foam Pump/Motor Assembly

(Shown with Bypass Valve when configured for MDT II, MST or no tank selector option)

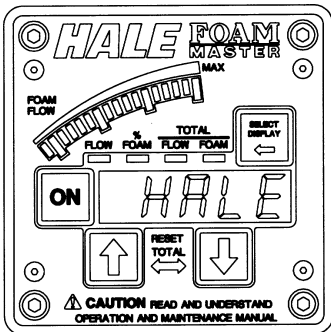

Control Unit

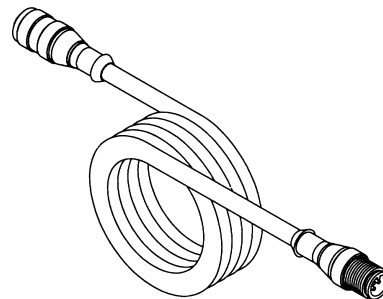

6-Pin Control Cable

16.5 Feet (Recommended) (P/N 013-2020-05-0)

6.5 Feet (Available) (P/N 013-2020-02-0)

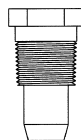

Check Valve/Injector Fitting

Dual Foam Concentrate Tank System Options

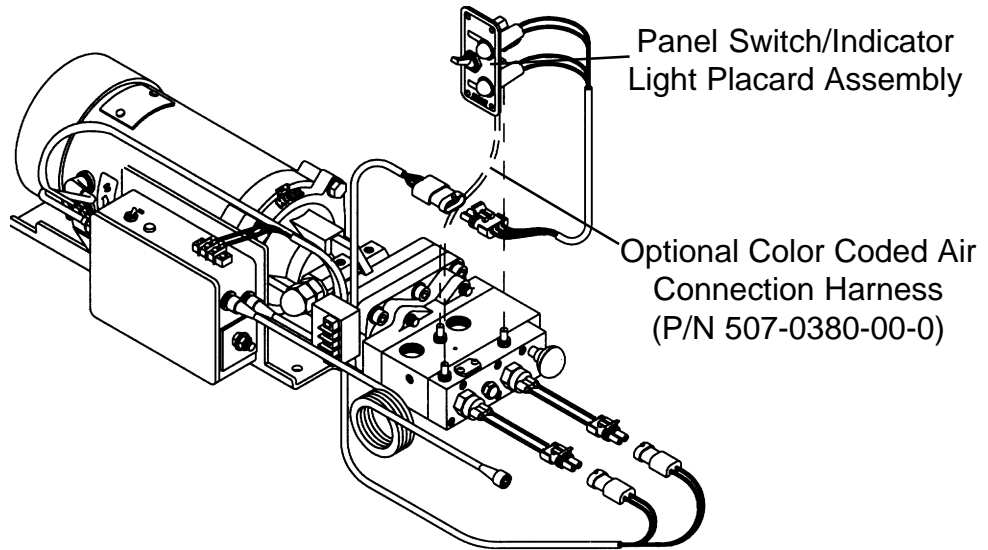

Foam Pump/Motor Assembly with Air Dual Tank (ADT) Selector (P/N 538-1640-02-0)

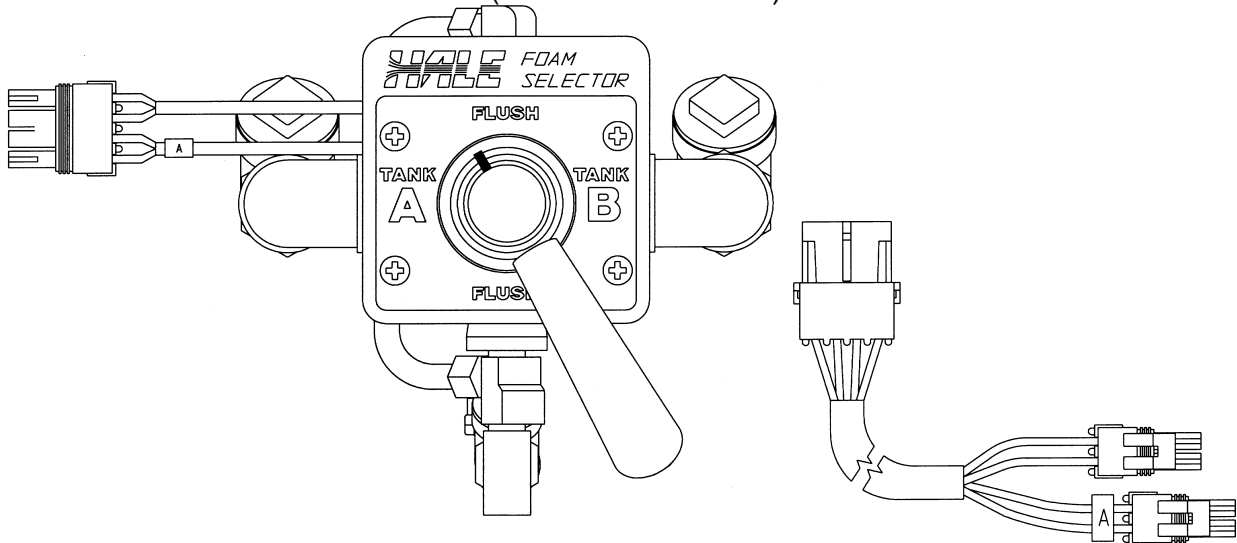

Manual Dual Tank (MDT II) Selector and Wiring Harness (P/N 538-1490-11-0)

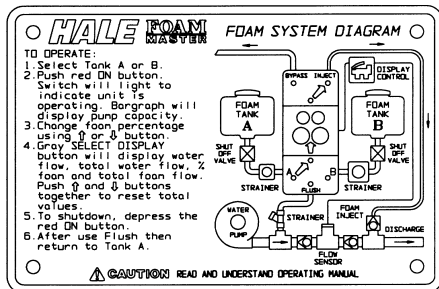

Dual Tank Instruction Placard/System Diagram (P/N 101-1630-07-0)

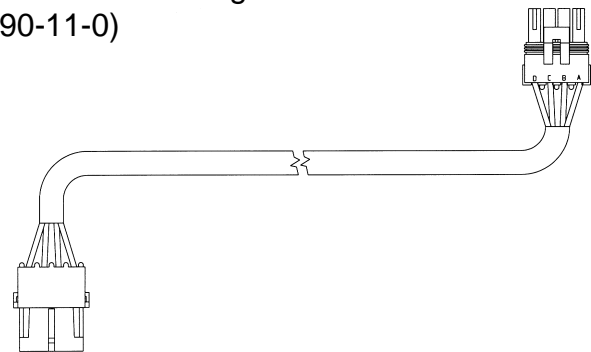

MDT II Wiring Harness Extension (P/N 513-0320-02-0)

Single Foam Concentrate Tank Options

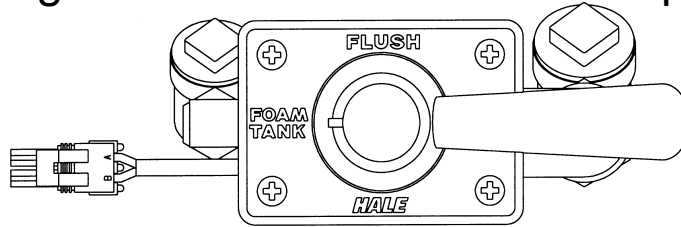

Manual Single Tank (MST) Selector

Provides FoamPump Flushing Capabilities for a Single Tank System
(P/N 538-1490-12-0)

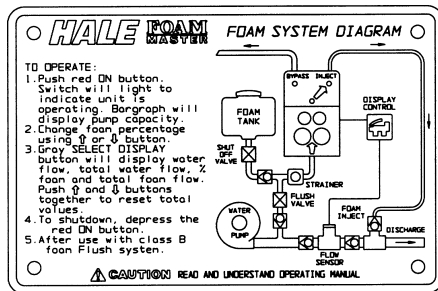

Single Tank Instruction Placard/System Diagram
(P/N 101-1630-12-0)

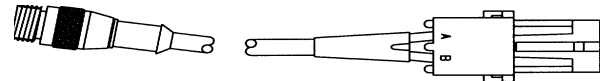

MST Wiring Harness
(P/N 513-0320-04-0)

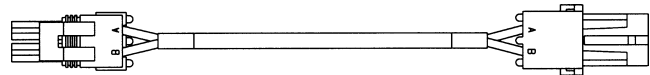

MST Wiring Harness Extension
72 inches (1829 mm) long
(P/N 513-0320-07-0)

Foam Concentrate Strainers

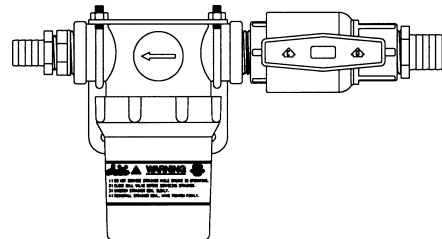

In-Line Strainer/Valve Assembly
(P/N 510-0190-00-0)

(Do Not Use If Subject to Flushing Water Pressure)

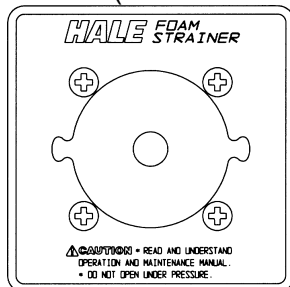

FS-15 STRAINER
(P/N 510-0150-00-0)

($\frac{3}{4}$ Inch NPT Threads. Use With Class A and thin Class B Foam Concentrates)

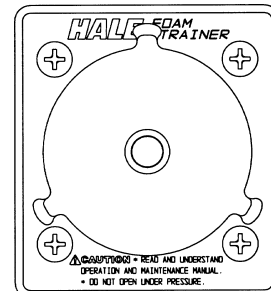

FS-25 STRAINER
(P/N 510-0180-00-0)

(1 Inch NPT Threads. Use With Class A and Class B Foam Concentrates)

Hale FS Series Strainers

(Use When Strainer is Subjected to Flushing Water Pressure)

Low Tank Level Sensor Options

(One Low Tank Level Sensor is Required for Each Foam Tank)

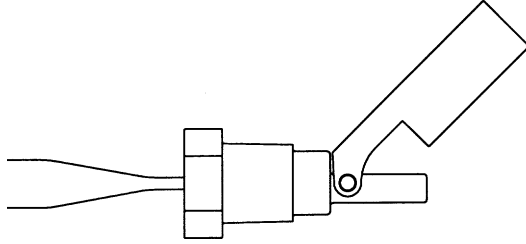

Side Mount Low Tank Level Sensor
(P/N 200-2110-02-0)
($\frac{1}{2}$ Inch NPT Threaded Bushing to Mount
From Outside Foam Tank)

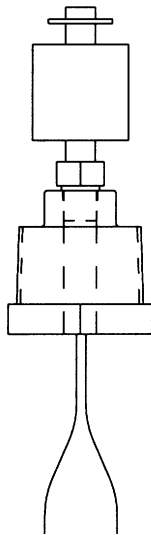

Brass Bottom Mount Low Tank Level
Sensor
(P/N 200-2110-04-0)
(1 Inch NPT Threaded Bushing to Mount
From Outside Foam Tank)

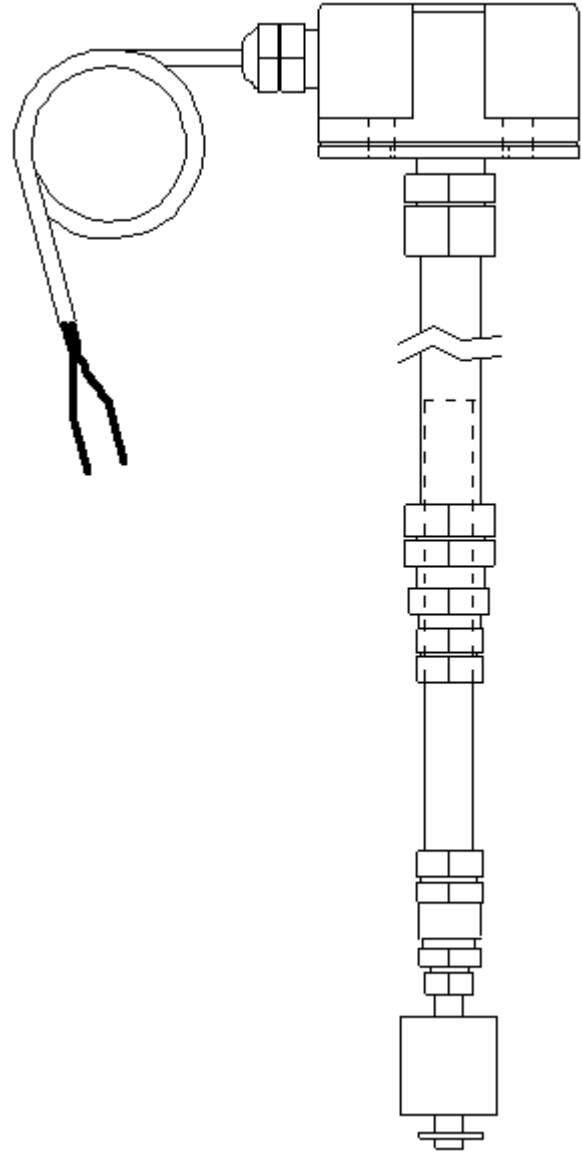

Top Mount Low Tank Level Sensor
Assembly
(P/N 200-2110-06-0)
(Extends From 2- $\frac{1}{2}$ Feet to 5 Feet Long.
May be Cut Shorter)

Flowsensors

Each Hale Foammaster System Requires at Least One Flowsensor to Operate. Flowsensors must be Selected Based on the Minimum and Maximum Water Flow in the Foam Capable Discharge. Following is a List of HPF Flowsensor Models, Pipe Size and Rated Flow Range:

US PIPE THREADED FLOWSENS

MODEL	PART NUMBER	THREADS	VICT
HPF15	538-1600-15-0	1-1/2 NPT	2-
HPF20	538-1600-20-0	2 NPT	
HPF25	538-1600-25-0	2-1/2 NPT	3-
HPF30	538-1600-30-0	3 NPT	
HPF40	538-1600-40-0	4 NPT	

ISO METRIC FLOWSENSOR

MODEL	PART NUMBER	THREADS	VICT
HPF15 ISO	538-1600-16-0	228/1-G1-1/2(ISO)	2-
HPF20 ISO	538-1600-21-0	228/1-G2(ISO)	
HPF25 ISO	538-1600-26-0	228/1-G2-1/2(ISO)	3-
HPF30 ISO	538-1600-31-0	228/1-G3(ISO)	
HPF40 ISO	538-1600-41-0	228/1-G4(ISO)	

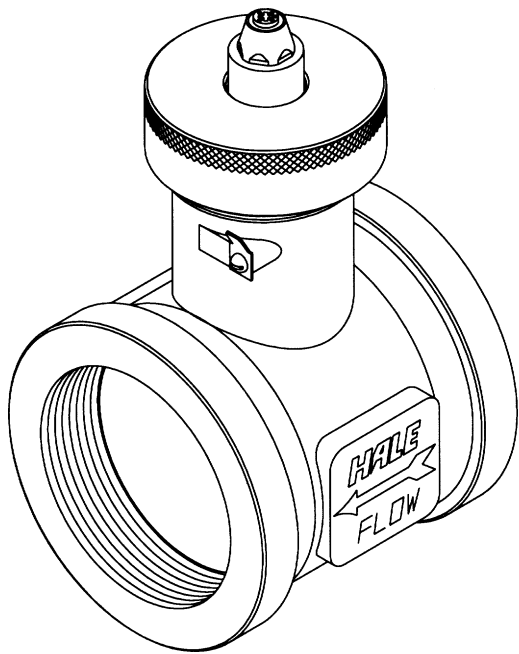

HPF Flowsensor

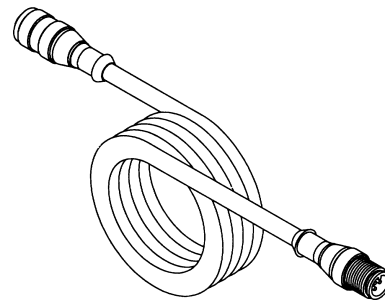

4-Pin Flowsensor Cable
16.5 Feet (Recommended) (P/N 013-2010-05-0)
6.5 Feet (Available) (P/N 013-2010-02-0)

Flowsensor Installation Dimensions

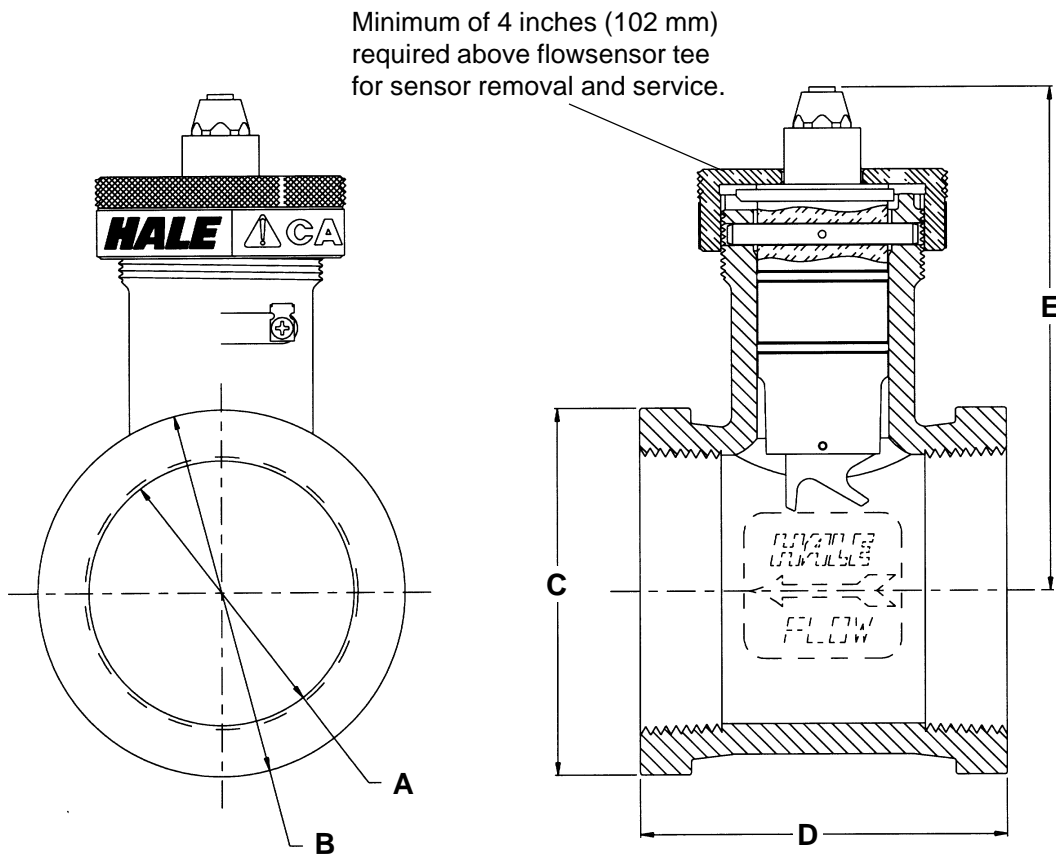

HPF MODEL NUMBER	A THREADS	B VICTAULIC	C OUTSIDE DIAMETER	D LENGTH	E HEIGHT
HPF15	1-1/2 NPT	2-1/2	2.88 IN. (73 MM)	4.50 IN. (114 MM)	5.30 IN. (109 MM)
HPF20	2 NPT	3	3.50 IN. (89 MM)	4.50 IN. (114 MM)	5.55 IN. (116 MM)
HPF25	2-1/2 NPT	3-1/2	4.00 IN. (102 MM)	4.50 IN. (114 MM)	5.75 IN. (121 MM)
HPF30	3 NPT	4	4.50 IN. (114 MM)	4.50 IN. (114 MM)	6.06 IN. (129 MM)
HPF40	4 NPT	5	5.58 IN. (142 MM)	5.00 IN. (127 MM)	6.42 IN. (138 MM)
HPF15 ISO	1-1/2 ISO	2-1/2	2.88 IN. (73 MM)	4.50 IN. (114 MM)	5.19 IN. (106 MM)
HPF20 ISO	2 ISO	3	3.50 IN. (89 MM)	4.50 IN. (114 MM)	5.42 IN. (112 MM)
HPF25 ISO	2-1/2 ISO	3-1/2	4.00 IN. (102 MM)	4.50 IN. (114 MM)	5.61 IN. (117 MM)
HPF30 ISO	3 ISO	4	4.50 IN. (114 MM)	4.50 IN. (114 MM)	5.92 IN. (125 MM)
HPF40 ISO	4 ISO	5	5.58 IN. (142 MM)	5.00 IN. (127 MM)	6.29 IN. (134 MM)

Foam Discharge Multiplexing Display Unit

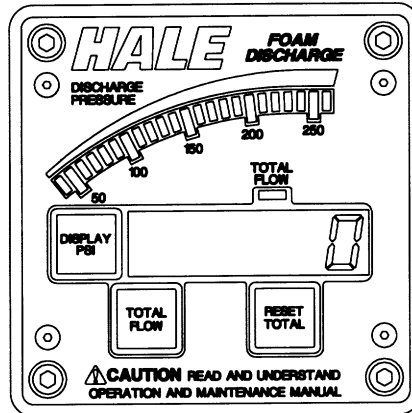

Foam Discharge Multiplexing Display Unit (Including Pressure Transducer)
(P/N 200-2550-00-0)

(Required Component When Number of Flowsensors is Greater Than One)

(When Multiplexing Units are Installed a FoamMaster Power Filter Kit (P/N 546-1870-00-0)
Must be Installed)

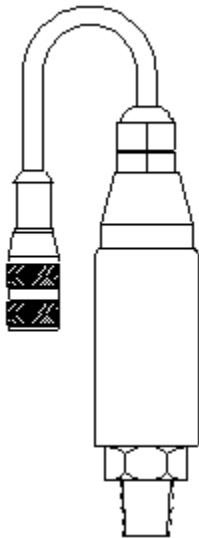

Pressure Transducer

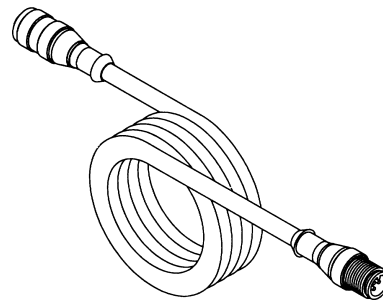

6-Pin Pressure Transducer Cable
16.5 Feet (Recommended) (P/N 013-2020-05-0)
6.5 Feet (Available) (P/N 013-2020-02-0)

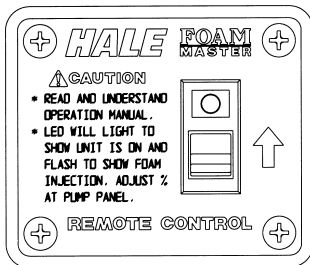

Remote Activation Switch
(P/N 513-0330-01-0)

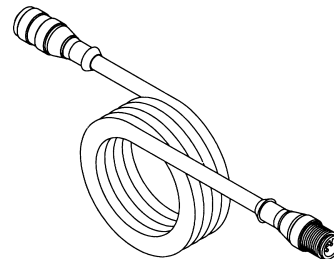

4-Pin Remote Activation Switch Cable
33 Feet (Recommended) (P/N 013-2010-10-0)
16.5 Feet (Available) (P/N 013-2010-05-0)
6.5 Feet (Available) (P/N 013-2010-02-0)

Additional Components

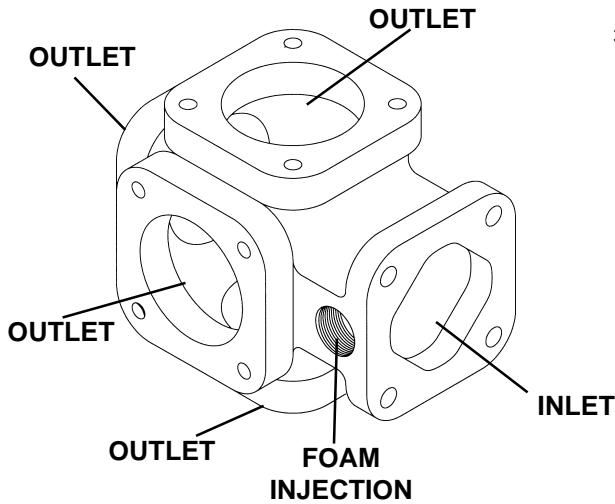

Mini Manifold
(P/N 178-0320-02-0)

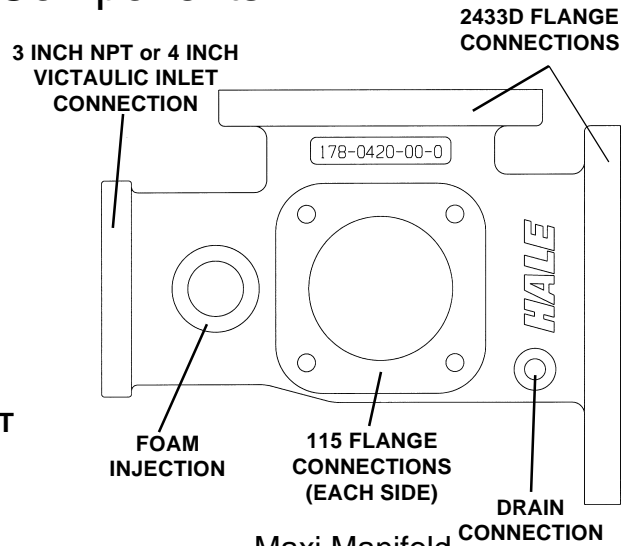

Maxi Manifold
(P/N 178-0420-00-0)

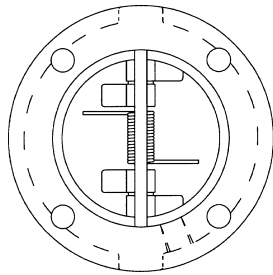

3 Inch "115" Check Valve
(P/N 038-1570-00-0)

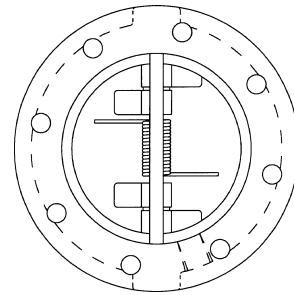

4 Inch "2433D" Check Valve
(P/N 038-1570-04-0)

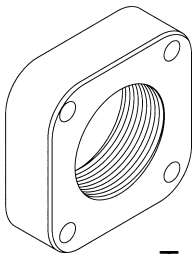

THREADS	PART NUMBER
3 INCH NPT	115-0080-00-0
2-1/2 INCH NPT	115-0070-00-0
2 INCH NPT	115-0060-00-0
BLANK	115-0050-00-0

Type 115 Flange

Use 3 and 2-½ inch NPT with 3 inch check valves.
Also available with 1-½ and 2 inch NPT threads.

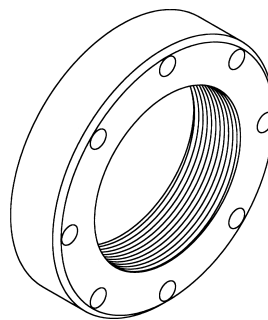

THREADS	PART NUMBER
4 INCH NPT	115-0040-00-0
3 INCH NPT	115-0030-00-0
2-1/2 INCH NPT	115-0020-00-0
BLANK	115-0010-00-0

Type 2433D Flange

Use 4 inch NPT with 4 inch check valves.
Also available with 2-½ and 3 inch NPT threads.

Additional Components

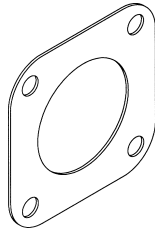

115
(P/N 046-0050-00-0)

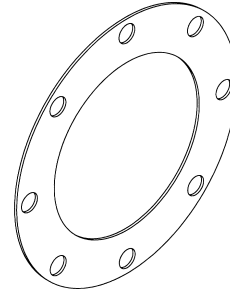

2433D
(P/N 046-0040-00-0)

Flange Gaskets

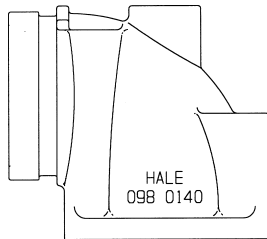

Close Fit Flanged Elbow
(P/N 098-0140-00-0)
115 flange inlet with 3 inch Victaulic outlet.

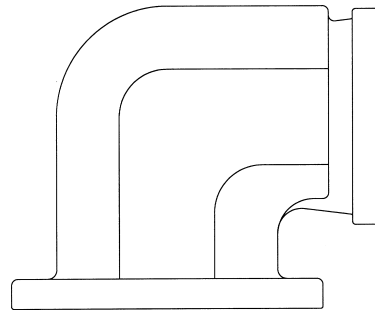

Close Fit Flanged Elbow
(P/N 098-0190-00-0)
2433D flange inlet with 3 inch female NPT
and 4 inch Victaulic outlet.

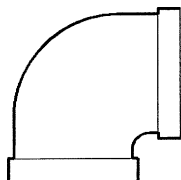

Close Fit Flanged Elbow
(P/N 098-0050-00-0)
115 flange inlet with 2-½ inch female NPT outlet.

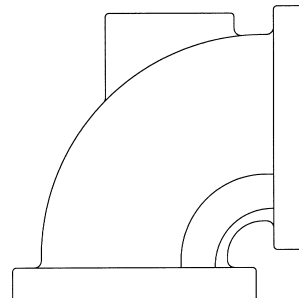

Close Fit Flanged Elbow
(P/N 098-0020-00-0)
115 flange inlet with 115 flange outlet.

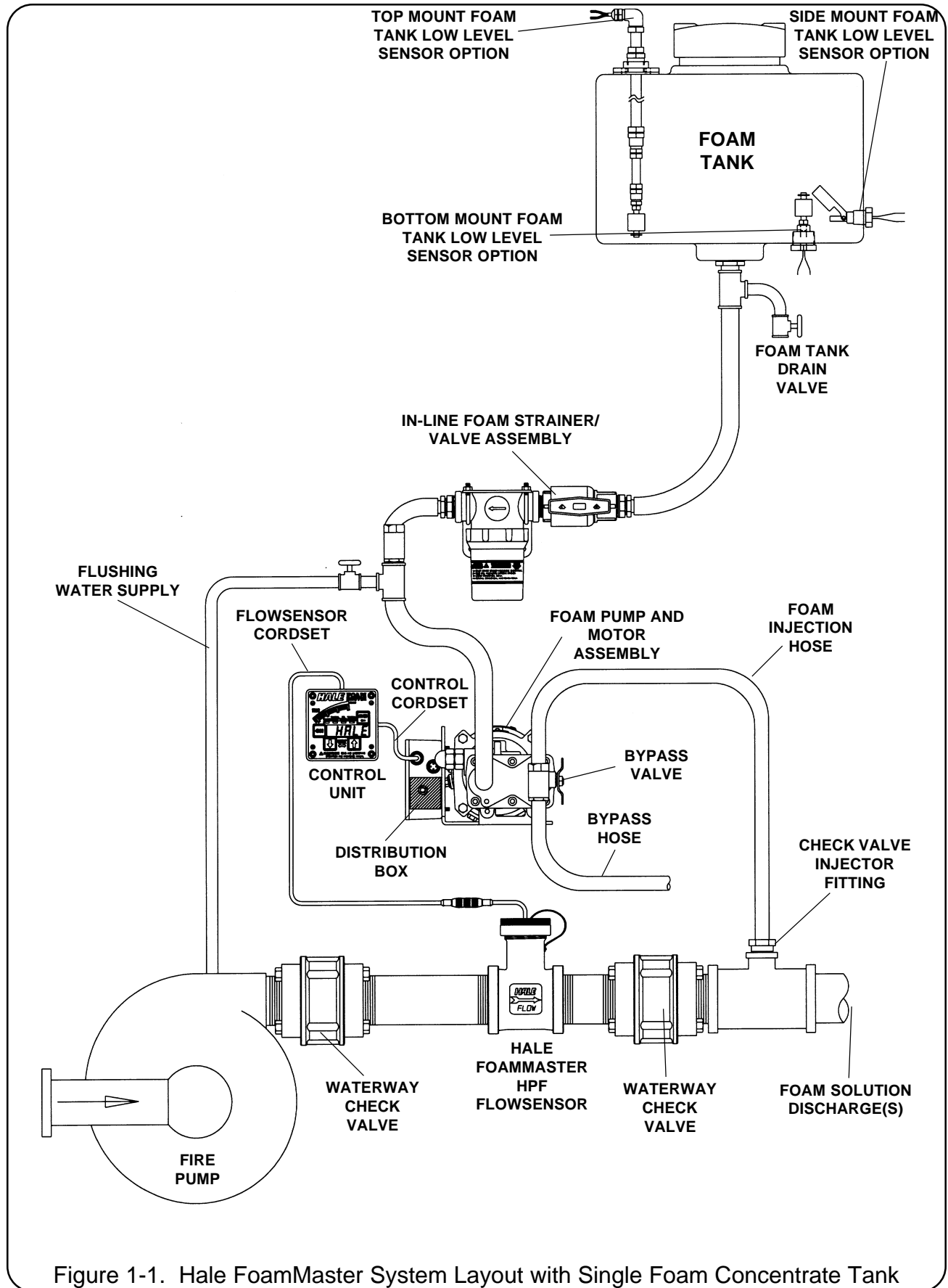

Figure 1-1. Hale FoamMaster System Layout with Single Foam Concentrate Tank

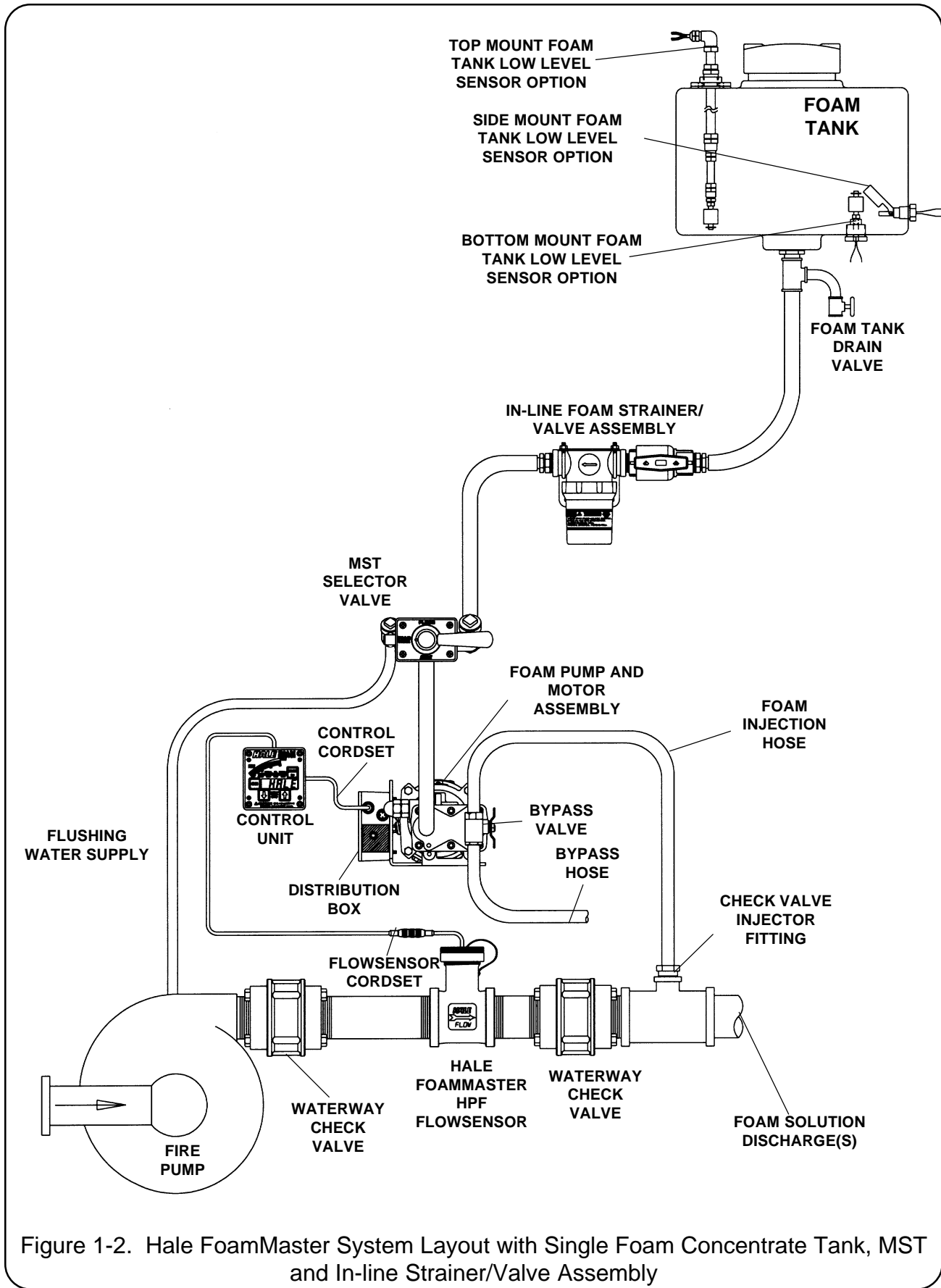

Figure 1-2. Hale FoamMaster System Layout with Single Foam Concentrate Tank, MST and In-line Strainer/Valve Assembly

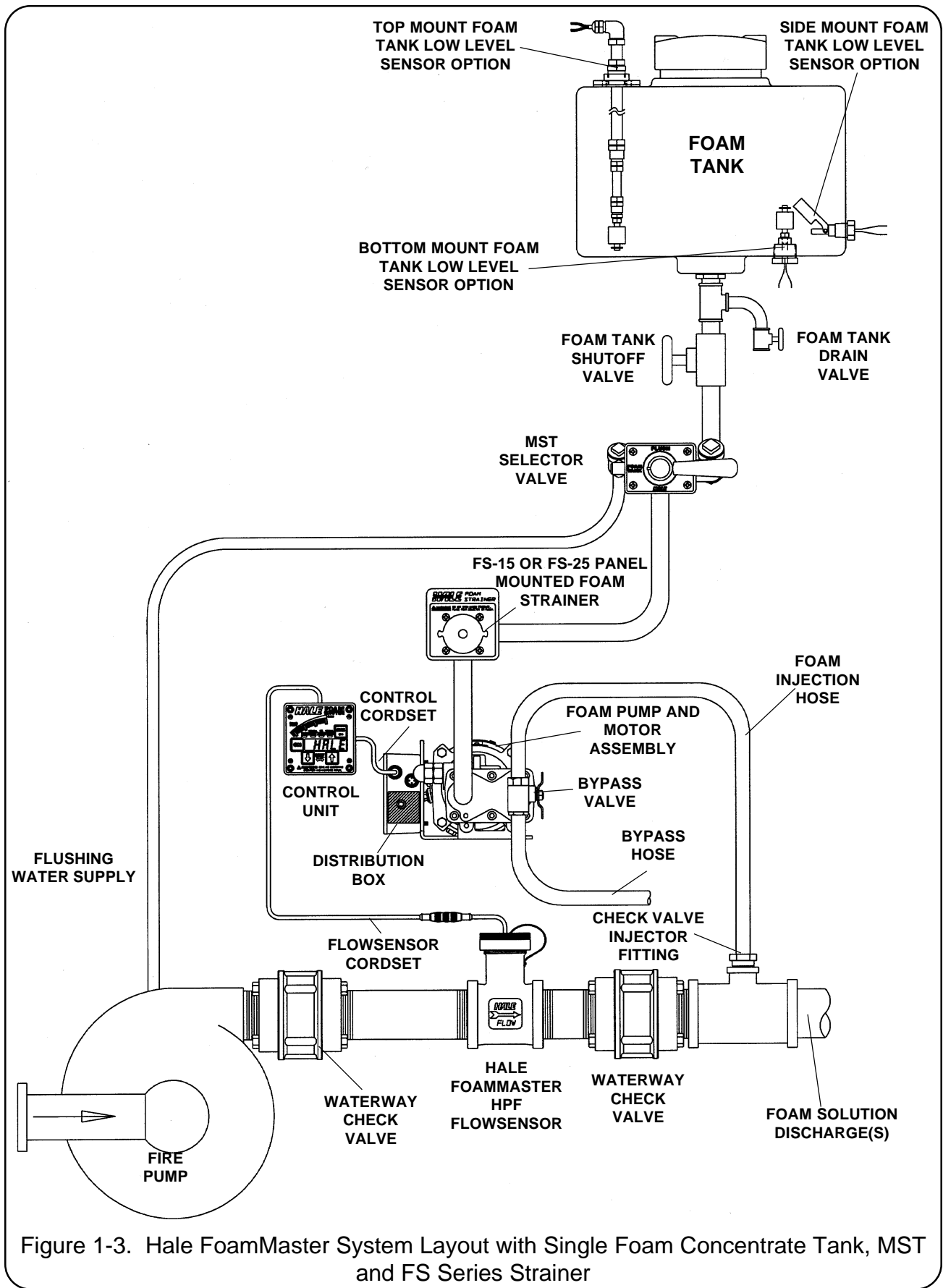

Figure 1-3. Hale FoamMaster System Layout with Single Foam Concentrate Tank, MST and FS Series Strainer

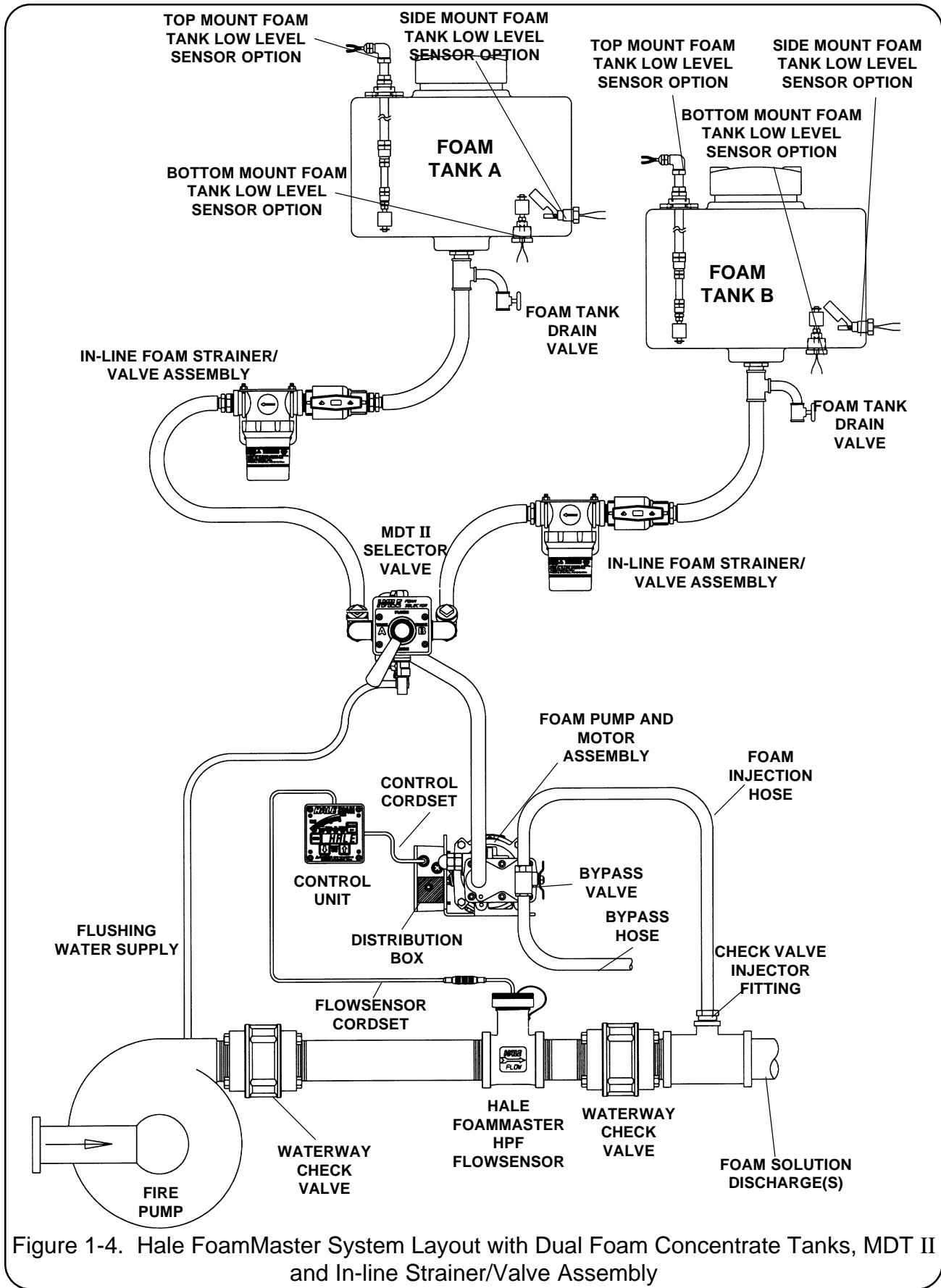

Figure 1-4. Hale FoamMaster System Layout with Dual Foam Concentrate Tanks, MDT II and In-line Strainer/Valve Assembly

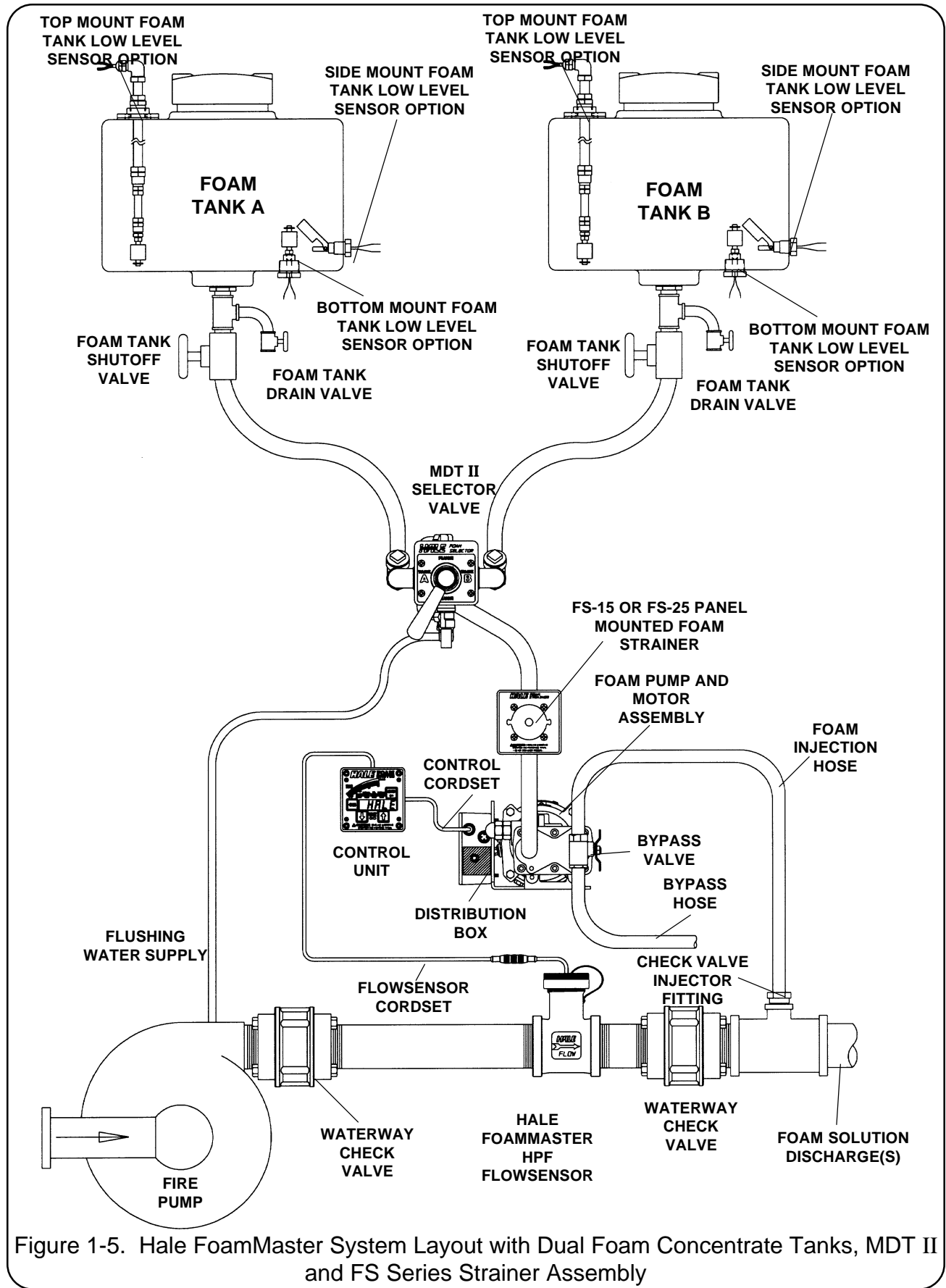

Figure 1-5. Hale FoamMaster System Layout with Dual Foam Concentrate Tanks, MDT II and FS Series Strainer Assembly

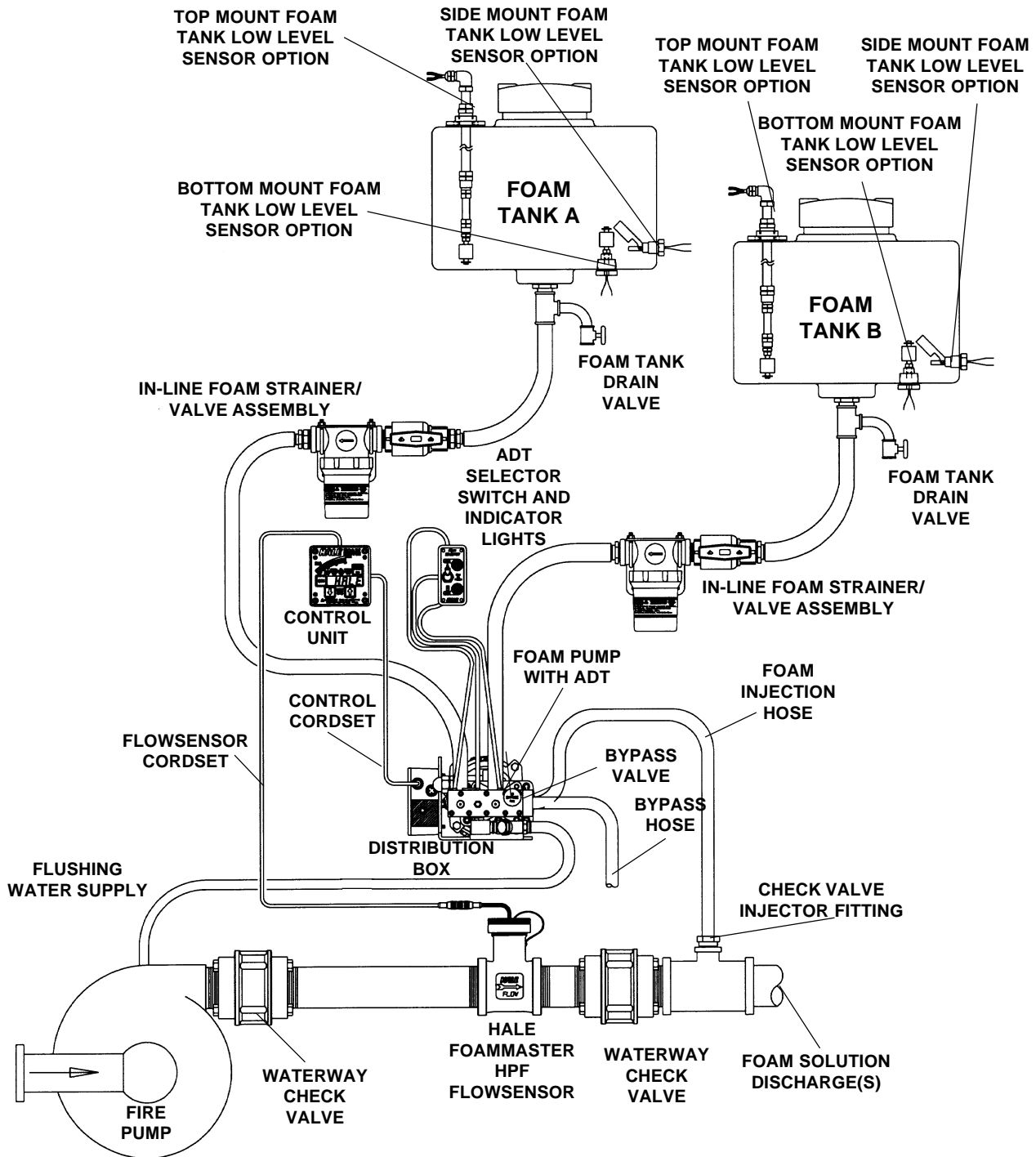

Figure 1-6. HALE FoamMaster System Layout with Dual Foam Concentrate Tanks, ADT and In-line Strainer/Valve Assemblies

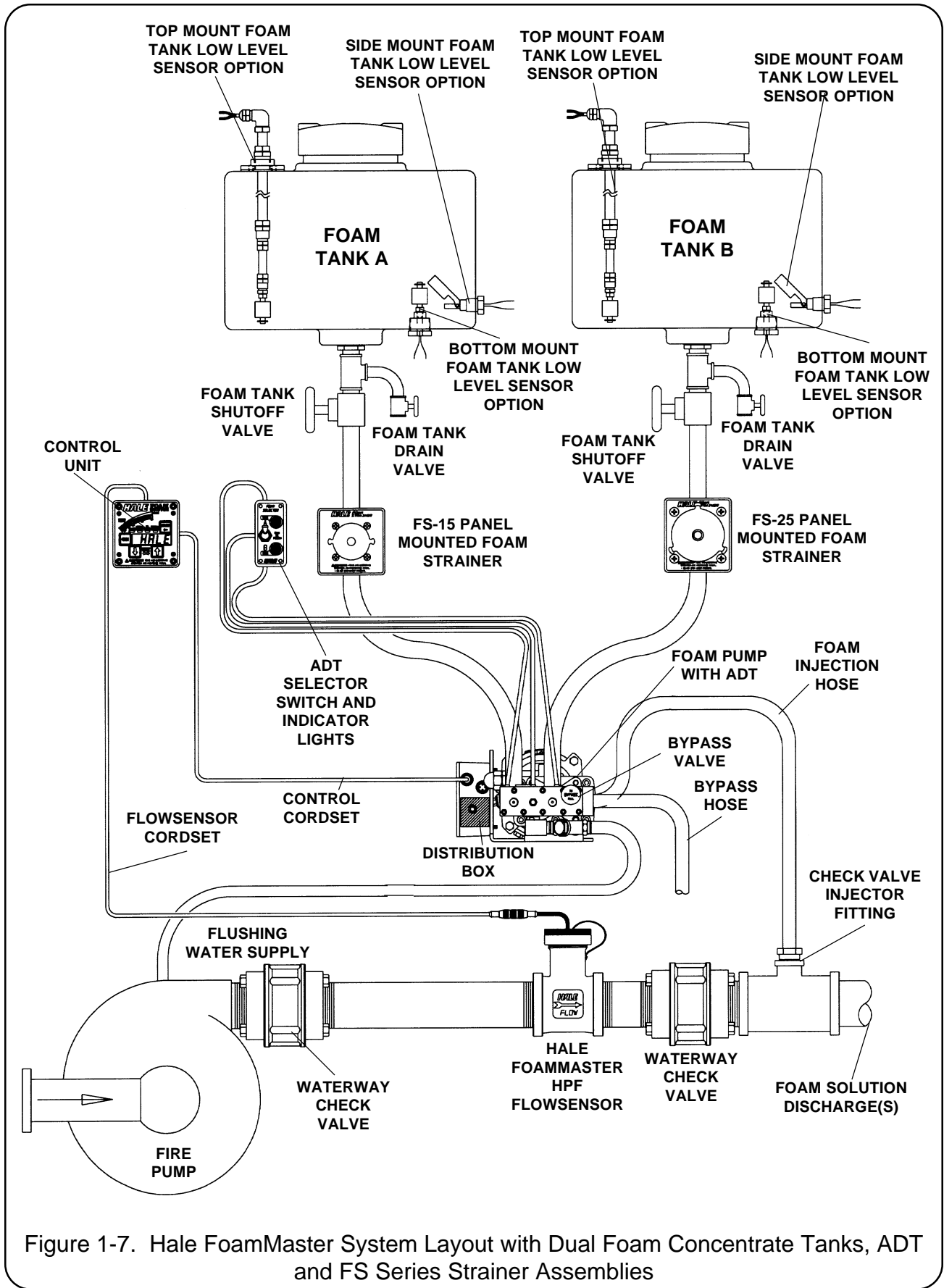

Figure 1-7. Hale FoamMaster System Layout with Dual Foam Concentrate Tanks, ADT and FS Series Strainer Assemblies

HALE

FOAM MASTER

ROTARY GEAR PUMP ELECTRONIC FOAM PROPORTIONING SYSTEM

DESCRIPTION, INSTALLATION AND OPERATION
MANUAL

SECTION II INSTALLATION

NOTICE: This manual section provides information to assist the OEM with installation and initial set-up of Hale FoamMaster systems on an apparatus. This manual section can be used as a stand alone section or in conjunction with other sections of the complete manual.

HALE PRODUCTS, INC. • A Unit of IDEX Corporation • 700 Spring Mill Avenue • Conshohocken, PA 19428 • TEL: 610-825-6300 • FAX: 610-825-6440



Hale Products cannot assume responsibility for product failure resulting from improper maintenance or operation. Hale Products is responsible only to the limits stated in the product warranty. Product specifications contained in this material are subject to change without notice.



SAFETY

Hale FoamMaster systems are designed to provide reliable and safe foam concentrate injection. Before installing or operating a Hale FoamMaster system read all safety precautions and follow carefully to ensure proper installation and personnel safety.

WARNINGS

1. Do not permanently remove or alter any guard or insulating devices or attempt to operate the system when these guards are temporarily removed.
2. To prevent electrical shock always disconnect the primary power source before attempting to service any part of the Hale FoamMaster system.
3. All electrical systems have the potential to cause sparks during service. Take care to eliminate explosive or hazardous environments during service/repair.
4. To prevent system damage or electrical shock the main power supply wire will be the last connection made to the Hale FoamMaster distribution box.
5. Release all pressure then drain all concentrate and water from the system before servicing any of its component parts.
6. Rotating drive line components can cause injury. When working on components of the Hale FoamMaster system be careful of rotating components.
4. Hale FoamMaster systems are designed for use on negative ground direct current electrical systems only.
5. Do not mount radio transmitter or transmitter cables in direct or close contact with the Hale FoamMaster unit.
6. Before connecting the cordsets inspect the seal washer in the female connector. If the seal washer is missing or damaged, water can enter the connector causing corrosion of the pins and terminals resulting in possible system failure.
7. Always disconnect the power cable, ground straps, electrical wires and control cables from the control unit or other Hale FoamMaster equipment before electric arc welding at any point on the apparatus. Failure to do so could result in a power surge through the unit that could cause irreparable damage.
8. **DO NOT** connect the main power lead to small leads that are supplying some other device such as a light bar or siren. The Hale FoamMaster Model 3.3 and Model 5.0 require 60 AMP minimum current. The Hale FoamMaster Model 3.0 requires 40 AMP minimum current. Use correct gauge wire as specified.

CAUTIONS

1. Foam tank low level sensors must be utilized to protect the Hale FoamMaster from dry running. Failure to use low level sensors with the Hale FoamMaster system will void warranty.
2. Do not operate system at pressures higher than the maximum rated pressure.
3. Use only pipe, hose, and fittings from the foam pump outlet to the injector fitting, which are rated at or above the maximum pressure rating at which the water pump system operates.
9. When operating the Hale FoamMaster in Simulated Flow mode an outlet for the foam concentrate must be provided to prevent excessive pressure buildup in discharge piping or hoses.
10. Unless engaged in Class B foam operations, the Hale FoamMaster ADT toggle switch or Hale FoamMaster MDT II selector handle must be in the **TANK A** position. If the toggle switch or selector handle is in the **FLUSH** position when the Hale FoamMaster foam pump is started the foam pump will only run for 20 seconds and shut down.

11. Make sure the foam tank and foam concentrate suction hoses are clean before making final connection to foam pump. If necessary flush tank and hoses prior to making connection.

NOTES

1. Check all hoses for weak or worn conditions after each use. Ensure that all connections and fittings are tight and secure.
2. Ensure that the electrical source of power for the unit is a negative ground DC system, of correct input voltage, with a reserve minimum current available to drive Hale FoamMaster system.
3. The in-line strainer/valve assembly is a low pressure device and WILL NOT withstand flushing water pressure. When installing the in-line strainer in systems equipped with Hale MDT II or Hale MST make sure the in-line strainer/valve assembly is in the hose on the inlet side of the valve. If the strainer will be subject to flushing water pressure, use Hale FS series strainers.
4. When determining the location of Hale FoamMaster components keep in mind piping runs, cable routing and other interferences that will hinder or interfere with proper system performance.
5. The Hale HPF flowsensor is assembled and tested at the factory. Removal of the flow sensor from the tee is not necessary or recommended for installation in the system.
6. Always position the check valve/injector fitting at a horizontal or higher angle to allow water to drain away from the fitting. This will avoid sediment deposits or the formation of an ice plug.
7. The cordsets provided with each Hale FoamMaster system are 100% electrically shielded assemblies. Never attempt to shorten or lengthen the molded cables. If necessary order longer or shorter cordsets from Hale Products to suit the particular installation.
8. The cordsets provided with each Hale FoamMaster system are indexed so they only go in the correct receptacle and they can only go in one way. When making cordset connections DO NOT force mismatched connections as damage can result in improper system operation.
9. The system can only perform when the electrical connections are sound, so make sure each one is correct.
10. The cables shipped with each Hale FoamMaster system are 100% tested at the factory with that unit. Improper handling and forcing connections can damage these cables which could result in other system damage.
11. There are no user servicable parts inside Hale FoamMaster system electrical/electronic components. Opening of these components (distribution box, control unit, foam discharge multiplexing display unit) will void warranty.
12. Use mounting hardware that is compatible with all foam concentrates to be used in the system. Use washers, lockwashers and capscrews made of brass or 300 series stainless steel.
13. When making wire connections make sure they are properly insulated and sealed using an adhesive filled heat shrink tubing.
14. Before running wires from the low tank switches to the A-B switch box make sure the wire from Tank A is identified and properly labeled.
15. **ALWAYS** connect the primary positive power lead from the terminal block to the master switch terminal or the positive battery terminal using minimum 4 AWG type SGX (SAE J1127) chemical resistant battery cable and protect with wire loom.
16. Prevent corrosion of power and ground connections by sealing these connections with silicone sealant provided.
17. Prevent possible short circuit by using the rubber boot provided to insulate the primary power connection at the Hale FoamMaster distribution box.

APPARATUS INSTALLATION PLANNING

Differences in apparatus plumbing and foam system configuration make it impractical to show exactly how each Hale FoamMaster system is installed on a particular apparatus. The information contained in this section, however, will apply to most situations and should be used when designing and installing a Hale FoamMaster system. System plumbing and electrical diagrams are provided at the end of this installation section to assist the apparatus manufacturer with installation of the Hale FoamMaster system.

The following subsections provide the system installer with guidelines for a complete system installation. Before proceeding with system installation carefully review the procedures that follow to ensure the system is properly designed. The subsection titled **Installer Supplied Component Recommendations** lists those components that have been tested with Hale FoamMaster and provide the best system performance. Use of the recommended materials and specified parts will ensure a virtually maintenance free installation.

The Hale FoamMaster system is supplied with six major components that must be located on the apparatus. The major components of the Hale FoamMaster system are:

- Foam pump and motor assembly
- Control unit
- In-Line foam strainer/valve assembly
- Instruction/system diagram placard
- HPF flowsensor
- Check valve injector fitting

Optional components to enhance system installation and operation that require mounting on the apparatus include:

- FS15 or FS25 panel mounted foam strainer
- ADT operating switch and indicator lights (ADT valve is integral part of foam pump)
- Manual dual tank (MDT II) selector valve
- Manual single tank (MST) selector valve
- Foam discharge multiplexing display units
- Additional HPF flowsensors
- Line pressure transducers
- Mini or Maxi Manifolds
- Flanged elbows
- Foam tank(s)
- Remote activation switch

IMPORTANT: When determining the locations of Hale FoamMaster components being installed keep in mind piping runs, cable routing and other interferences that will hinder or interfere with proper system performance.

FOAM PUMP and MOTOR ASSEMBLY: Ideally the foam pump and motor assembly should be located in an area that is protected from road debris and excessive heat buildup. The foam system master power switch and bypass valve are located on the foam pump and motor assembly and access to these controls must be provided. It is recommended that the foam pump and motor assembly be located in a protected area but, foam concentrate gravity feed requirements or apparatus design limitations may necessitate locating the foam pump and motor assembly on a shelf in the apparatus pump house or attached to the apparatus frame. The motor and electrical components are designed to withstand the harsh environment encountered in an emergency apparatus environment.

The foam pump and motor assembly should be mounted below the discharge of the foam tank(s) to provide for gravity feed to the foam pump. The foam tank(s) must be located where refilling can be easily done with 5 gallon (19 liter) pails and other methods suitable to the end user. Most water tank manufacturers will build foam tanks into the booster tank. When specifying foam tank(s) make sure provisions are made for installation of the low tank level sensor as well as foam suction connections, tank drainage and proper fill openings per NFPA requirements.

FOAM CONCENTRATE STRAINER: Determine a location on the apparatus to mount the foam strainer.

CAUTION: The in-line strainer/valve assembly is a low pressure device and WILL NOT withstand flushing water pressure. When installing the in-line strainer in systems equipped with Hale MDT II or Hale MST make sure the in-line strainer/valve assembly is in the hose on the inlet side of the valve. If the strainer will be subject to flushing water pressure, use Hale FS series strainers.

Mount the in-line foam strainer/valve assembly in the foam concentrate hose from the foam tank to the foam pump suction connection, ADT, MDT II or MST. When determining the strainer location keep in mind the requirement for gravity feed of foam concentrate to the foam

pump through the strainer and avoid air traps in the hoses. Also, clearance must be provided to allow removal of the bowl assembly for cleaning the stainless steel mesh, to make hose connections to the strainer and for operation of the service valve.

If panel mounted FS series strainers are installed mount the strainer in the foam concentrate hose that supplies concentrate to the ADT, MDT II or MST. The FS series strainer may also be mounted in the outlet hose of the MDT II or MST. When determining strainer location on the operator panel keep in mind the requirement for gravity feed of foam concentrate to the foam pump through the strainer and avoid air traps in the hoses. Clearance must be provided behind the panel to allow for hose connections to the strainer. The installer must provide a strainer service isolation valve in the foam concentrate hose to prevent spillage during service. An MST or MDT II can serve this purpose also.

CONTROL UNIT and INSTRUCTION/SYSTEM

DIAGRAM PLACARD: Determine a location on the operator panel of the apparatus for the control unit and instruction/system diagram placard. These components must be located at the main pump operator position in close proximity to each other. Consideration must be given for routing the control cable from the control unit to the distribution box on the foam pump and motor assembly. If necessary, order longer or shorter cable assemblies to suit the location demands.

INSTALLER SUPPLIED COMPONENT RECOMMENDATIONS

Due to the many differences in apparatus configuration and apparatus design requirements the Hale FoamMaster system installer must supply components such as mounting brackets, piping, hoses, fittings and some electrical wiring. The following guidelines are recommendations for selection of these additional components for a complete system installation. The recommendations made reflect those materials and components that have been tested extensively with Hale FoamMaster systems and provide proven reliable performance.

FOAM CONCENTRATE SUCTION HOSE

The system installer must supply fittings and hoses from the foam tank to the inlet of the foam pump. All components selected will transfer foam concentrate therefore they must be compatible with the foam concentrates being used in the system. Hoses for Class A foam concentrates must have minimum $\frac{3}{4}$ inch (19 mm) inside diameter. Hoses for Class B foam concentrates must have minimum 1 inch (25 mm) inside diameter due to higher viscosity of the concentrates.

Hoses for the foam concentrate suction that WILL NOT be subjected to high pressure such as flushing water and foam concentrate discharge must have a rating of 23 in (584.2 mm) Hg vacuum and 50 PSI (3 BAR) pressure or greater. These hoses include the hose from the foam tank outlet to strainer inlet; strainer outlet to foam pump, ADT, MDT II or MST inlet.

NFPA requires that foam concentrate suction hose be clear to observe foam concentrate flow during foam pump operation.

RECOMMENDED COMPONENTS:

Hose: PVC, Kuriyama Kuri-Tec K7130 series

Fittings: Hose Barb Type; Brass, Stainless Steel or Nylon

When foam concentrate suction hose will be subject to flushing water pressure it must be rated for 23 in (584.2 mm) Hg vacuum and the maximum discharge pressure of the fire pump (500 PSI (34 BAR) minimum). These hoses include the hose from the outlet of the MDT II or MST to the foam pump inlet.

RECOMMENDED COMPONENTS:

Hose: Aeroquip 2580 Series or Equivalent Reinforced Hydraulic Hose.

Fittings: Brass or Stainless Steel Hose End Crimp or Reusable Type (Aeroquip 412 Series or Equivalent)

A foam tank shut-off valve and drain valve should be provided in the foam tank suction hose to allow strainer service, tank drainage and easier priming. These components are subject to the same material characteristics and pressure ratings as stated above. When the In-line strainer/valve assembly option is installed the shut-off valve is included as an integral part of the assembly and a separate valve is not required.

FOAM CONCENTRATE DISCHARGE HOSE

The system installer must supply fittings and hoses from the foam pump inject connection to the check valve/injector fitting inlet. All components selected will transfer foam concentrate therefore they must be compatible with the foam concentrates being used in the system.

The foam pump discharge port and check valve injector fitting connection port have ½ inch NPT threads. Hoses and fittings of ½ inch (13 mm) minimum inside diameter rated at 500 PSI (34 BAR) working pressure or maximum discharge pressure of the fire pump must be used. Fittings and hoses must be compatible with all foam agents to be used.

RECOMMENDED COMPONENTS:

- Hose: Aeroquip 2580-10 or Equivalent Reinforced Hydraulic Hose.
Fittings: Brass or Stainless Steel Hose End Crimp or Reusable Type (Aeroquip 412-9-10 or Equivalent)

Although air brake tubing has been used for foam concentrate discharge hose, it is not as flexible as the hydraulic hose and readily kinks during installation. Additionally, the air brake tubing may not meet NFPA 500 PSI (34 BAR) test requirements.

FOAM CONCENTRATE BYPASS HOSE

The foam concentrate bypass hose connection has ½ inch NPT threads. Hoses and fittings of ½ inch (13 mm) minimum inside diameter should be used as bypass hose. Since the bypass hose is used for calibration and draining the system it will not see high operating pressures, therefore, a hose with a lower pressure rating than the inject hose can be used. Fittings and hoses used must be compatible with all foam agents expected to be used. Use fittings made of brass or 300 series stainless steel compatible with all foam concentrates to be used.

RECOMMENDED COMPONENTS:

- Hose: Low Pressure Hydraulic Hose or Air Brake Tubing
Fittings: Brass or Stainless Steel

The foam concentrate bypass hose should be long enough to extend past the apparatus running board making foam pump setup and calibration simpler.

CHECK VALVES

Check valves must be installed on apparatus with foam systems to prevent contamination of the foam concentrate with water and contamination of the fresh water tank with foam. (Refer to figures 1-1 through 1-5) When a Hale FoamMaster foam injection system and related components are properly installed the required check valves are integral parts of the component parts.

NFPA standards require a check valve in the foam concentrate injection line at the injection point. The foam concentrate check valve shall have a 4 to 5 PSI (0.28 to 0.34 BAR) cracking pressure to prevent foam concentrate siphoning from the foam concentrate tank due to static head pressure. The check valve shall be rated for 500 PSIG (34 BAR) water pump discharge pressure. The Hale P/N 038-1790-00-0 Integral Check Valve/Injector fitting, a standard component included with the Hale FoamMaster system, meets these requirements and threads directly into the foam injection port on Hale manifolds.

Check valves must be installed in all water piping locations where foam concentrate could drain back into pumps or other components of the fire apparatus. As a minimum one check valve must be installed where the water piping that will supply foam solution connects to the fire pump discharge. To more effectively keep foam contamination out of the fire pump and water tank double check valves should be used. Separate two check valves by at least 8 inches (203 mm) of piping to form a dead zone between the check valves. Individual drain lines should be used on each check valve. The waterway check valves must be rated for 500 PSIG (34 BAR) working pressure.

Hale 3 inch "115" flange type check valves (Hale P/N 038-1570-00-0) can be used for most installations on pumps with "115" style

flanges. The Hale "115" flange type check valve has a 4-³/₈ inch bolt circle that fits standard Hale "115" flanges as well as 4-³/₈ inch bolt circle discharge flanges on other pumps. These check valves are rated for pressures up to 500 PSI (34 BAR) and flows up to 750 GPM (2839 LPM). Use 2-¹/₂ or 3 inch NPT threaded "115" flanges for mounting these check valves in piping runs.

Some installations may require higher flows and larger diameter piping. Use a Hale 4 inch 2433 flange type check valve (Hale P/N 038-1570-04-0) for these installations. This check valve has an 8 bolt, 5-³/₄ inch bolt circle and will fit pump discharge openings and flanges that have this configuration. The Hale 2433 check valve has a pressure rating of 500 PSI (34 BAR) and a flow rating of 1250 GPM (4731 LPM). The Hale 2433 style flange (Hale P/N 115-0040-00-0) has an 8 bolt, 5-³/₄ inch bolt circle and 4 inch NPT threads for in-line mounting of the 4 inch check valve.

FLUSHING WATER HOSE

Flush water connections for the Hale ADT, Hale FoamMaster MDT II or Hale MST must be made using ¹/₂ inch inside diameter tubing and appropriate fittings. The tubing and fittings used must be capable of withstanding the maximum fire pump discharge pressure (500 PSI (34 BAR) minimum) and should be compatible with foam concentrates being used in the system.

When the Hale ADT, Hale FoamMaster MDT II or Hale MST is installed a check valve is provided integral to the flushing water line connection to provide protection against contamination of the water system with foam concentrate.

Hale recommends the use of one of the above selector options to provide foam system flushing capabilities, but if the Hale FoamMaster system is ordered with the "no tank" option the system installer must provide proper hose, shutoff valve, check

valves and connections for flushing water for the system to be NFPA compliant. Additionally, when the Hale FoamMaster is installed without a Hale provided selector some operating and system protection features will not be available.

FOAM DISCHARGE DRAINS

Drains must be provided from foam capable discharge piping components to prevent freezing in cold weather. When designing the drain system care must be taken to prevent contamination of the water system with foam and the foam concentrate with water. Some multiple drain systems that allow individual drain lines to communicate also allow foam to bypass the installed check valves causing contamination of fire pump and the water or foam concentrate storage tanks.

Hale has an optional 7 port drain valve, Model DV7 (Hale P/N 529-5420-00-0) that provides individual drains with a single control to use for applications where a single point for multiple drains is required. If a Hale DV7 drain valve is not used then individual drain lines and valves for foam capable discharge piping are recommended. Hale type HD individual drain valves (Hale P/N 538-0600-01-0) (used without tees) are recommended.

ELECTRICAL REQUIREMENTS

The system installer must provide the primary power wire and a ground strap for the Hale FoamMaster system.

Primary power must be supplied from the main apparatus battery to the distribution box on the foam pump and motor assembly. The Hale FoamMaster Model 5.0 and Model 3.3 each require minimum 60 AMP electrical service and the Hale FoamMaster Model 3.0 requires minimum 40 AMP electrical service connected to the distribution box.

Primary electrical power must be supplied directly from the battery or the battery

master disconnect switch or solenoids to the Hale FoamMaster. Other electrical components must not be supplied from this wire. DO NOT connect the primer and Hale FoamMaster to the same power wire.

The toggle switch on the Hale FoamMaster distribution box should be left in the **ON** position at all times. So the Hale FoamMaster system is ready for immediate operation when the operator places the apparatus in pump mode, and to prevent battery power drain when the apparatus is not running, the primary power connection must be made so power is supplied to the Hale FoamMaster when the main apparatus electrical system is energized. Use of a solenoid with a 200 AMP peak, 100 AMP continuous rating is recommended.

With Hale FoamMaster Model 5.0 or Model 3.3, cable lengths up to 6 feet (1.8 meters) require minimum 4 AWG type SGX (SAE J1127) battery cable. Use solder lugs on cable ends with a 5/16 inch (8 mm) diameter hole. For Hale FoamMaster Model 3.0 or cable lengths greater than 6 feet (1.8 meters) refer to the following table for the recommended battery cable size for Hale FoamMaster system primary power wiring. When planning cable runs make sure the primary wires are routed by the shortest most direct route.

RECOMMENDED PRIMARY POWER CABLE SIZES		
Model 3.0	Models 3.3 & 5.0	Maximum Length
6 AWG	4 AWG	6 Ft (1.8 M) or Less
4 AWG	0 AWG	6 Ft (1.8 M) to 15 Ft (4.6 M)
0 AWG	00 AWG	15 Ft (4.6 M) or Longer

A braided flat ground strap is required for the ground connection to limit the RFI/EMI interference encountered with radios, computers or other sensitive electronic equipment. The ground strap should be a minimum of 1-¼ inches (32 mm) wide and be no longer than 18 inches (457 mm) long. The ground strap must have soldered flat

lug ends with 5/16 inch (8 mm) diameter holes. If the ground strap length exceeds 18 inches (457 mm), a wider ground strap should be used or use a double thickness of 1-¼ inches (32 mm) wide ground strap.

When making the ground strap connection make sure the connection is made to the chassis. Use minimum 5/16 inch (8 mm) diameter bolt or mounting stud for this connection.

Make sure the ground is attached directly to the chassis frame not the apparatus body work. Before making ground connection remove all paint, grease and coatings from the connection area. After making connection seal against corrosion.

NOTE: When an inline current shunt ammeter is installed on the apparatus or the Hale FoamMaster is used with Multiplexing Display Units with multiple water flow meters it is necessary to install a FoamMaster power filter kit (Hale P/N 546-1870-00-0) on the Hale FoamMaster foam pump.

FOAM CONCENTRATE TANK(S)

Foam concentrate tank(s) must be supplied to suit the capacity required for the apparatus application. The tank(s) must meet NFPA minimum standards for their design capacity, including filler size, vapor pressure venting, baffling and drain facilities. The following table lists recommended foam tank capacities for the different Hale FoamMaster models based on NFPA requirements for flammable liquid (Class B) fire suppression.

FOAMMASTER MODEL	RECOMMENDED FOAM TANK CAPACITY
MODEL 5.0	100 GAL. (379 Liters)
MODEL 3.3	66 GAL. (250 Liters)
MODEL 3.0	60 GAL. (227 Liters)

FOAM PUMP MOUNTING

Position the foam pump and motor assembly in the desired location on the apparatus. When installing the foam pump and motor assembly, the assembly should be kept in a **horizontal** position with the base plate on the bottom (see figure 2-1). Although the system is sealed and designed to be resistant to the harsh environment of fire fighting apparatus, a compartment with easy operator access is the recommended installation location.

The base plate of the foam pump and motor assembly must be anchored to a surface or structure that is rigid and of adequate strength to withstand the vibration and stresses of apparatus operation. Figures 2-2 and 2-3 provide the mounting envelope dimensions for the Hale FoamMaster foam pump and motor assembly.

Position the foam pump so the ON/OFF switch and bypass valve are easily accessible. When the Hale FoamMaster system is ordered without the ADT option, a separate bypass valve is included that may be removed from the foam pump and mounted on a truck panel for easier access. When the Hale FoamMaster system is ordered with the ADT option, the operating knob can be removed from the bypass valve actuator and an extension rod can be installed to permit remote operation. In either instance the foam pump and motor assembly must be located to permit proper operation of the bypass valve.

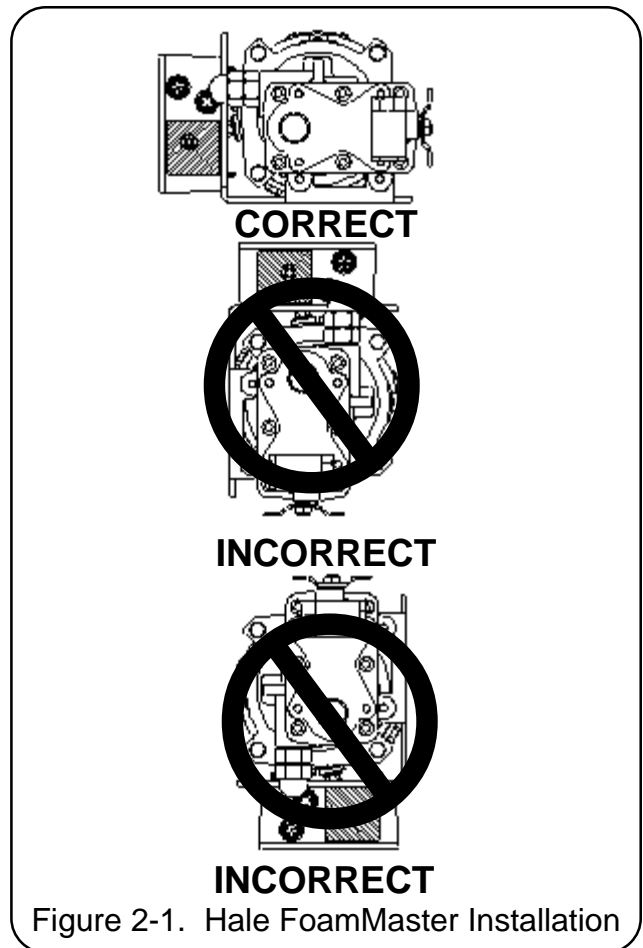

Figure 2-1. Hale FoamMaster Installation

Make sure the foam concentrate hoses can be properly routed to the inlet and outlet on the foam pump. Foam concentrate must gravity feed to the foam pump inlet from the foam tank(s). The foam pump must be mounted in an area to avoid excessive engine exhaust system or accessory heat buildup.

The base of the foam pump and motor assembly has predrilled mounting holes. These holes will accept $\frac{5}{16}$ inch (8 mm) diameter bolts and the apparatus mounting location needs to be drilled accordingly. The base plate can be used as a template to mark mounting hole location or a mounting hole layout drawing is provided as figure 2-4.

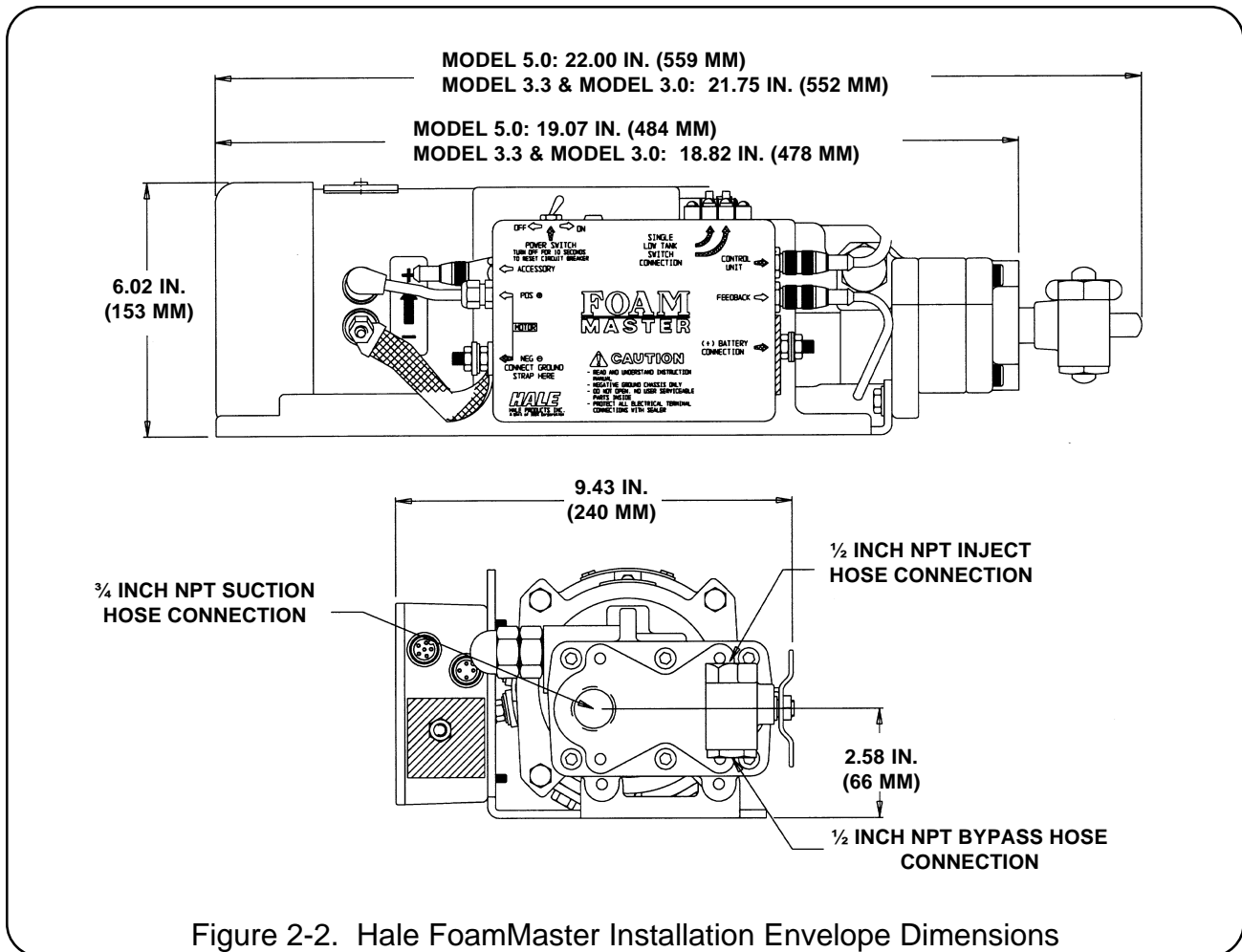

Figure 2-2. Hale FoamMaster Installation Envelope Dimensions

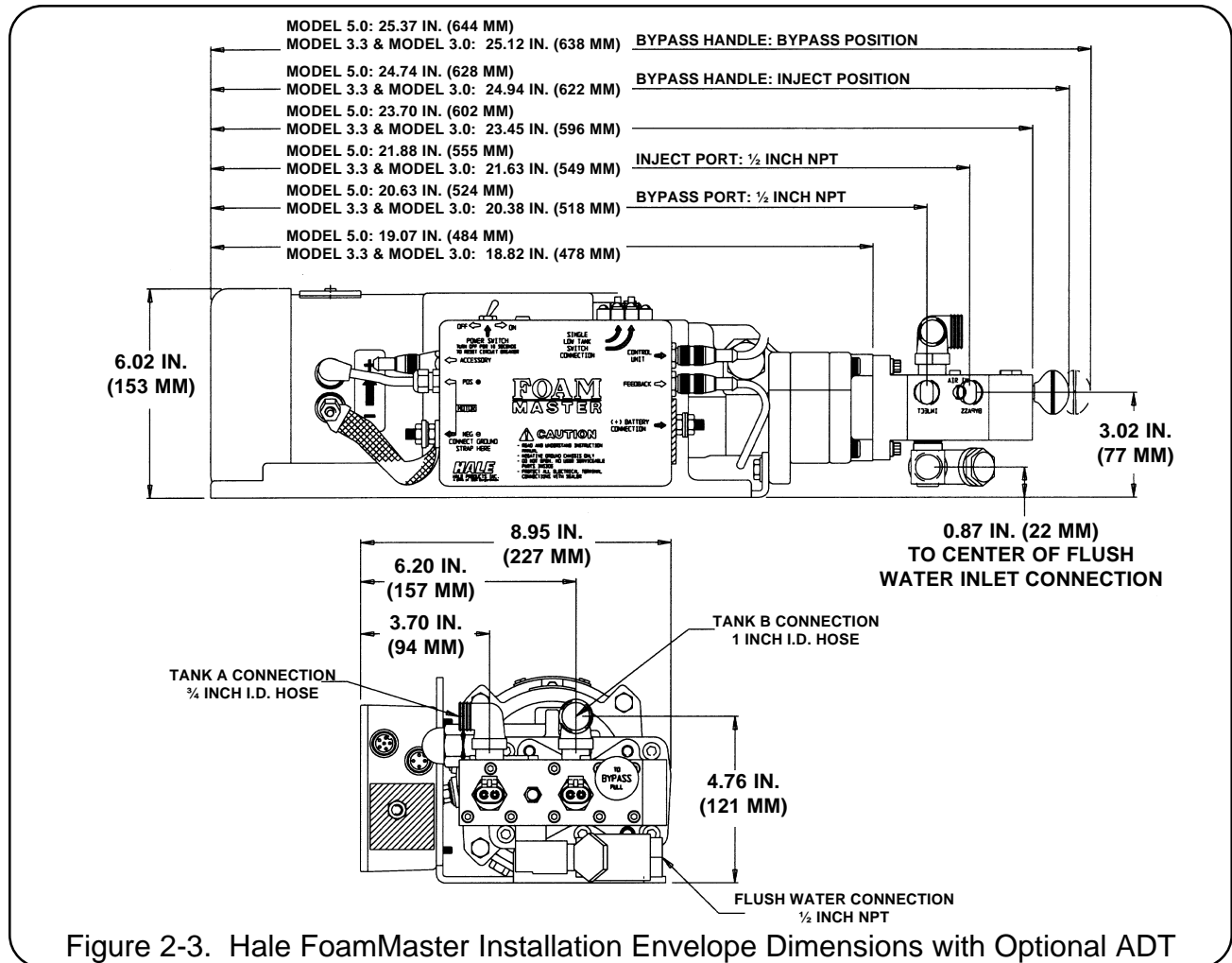

Figure 2-3. Hale FoamMaster Installation Envelope Dimensions with Optional ADT

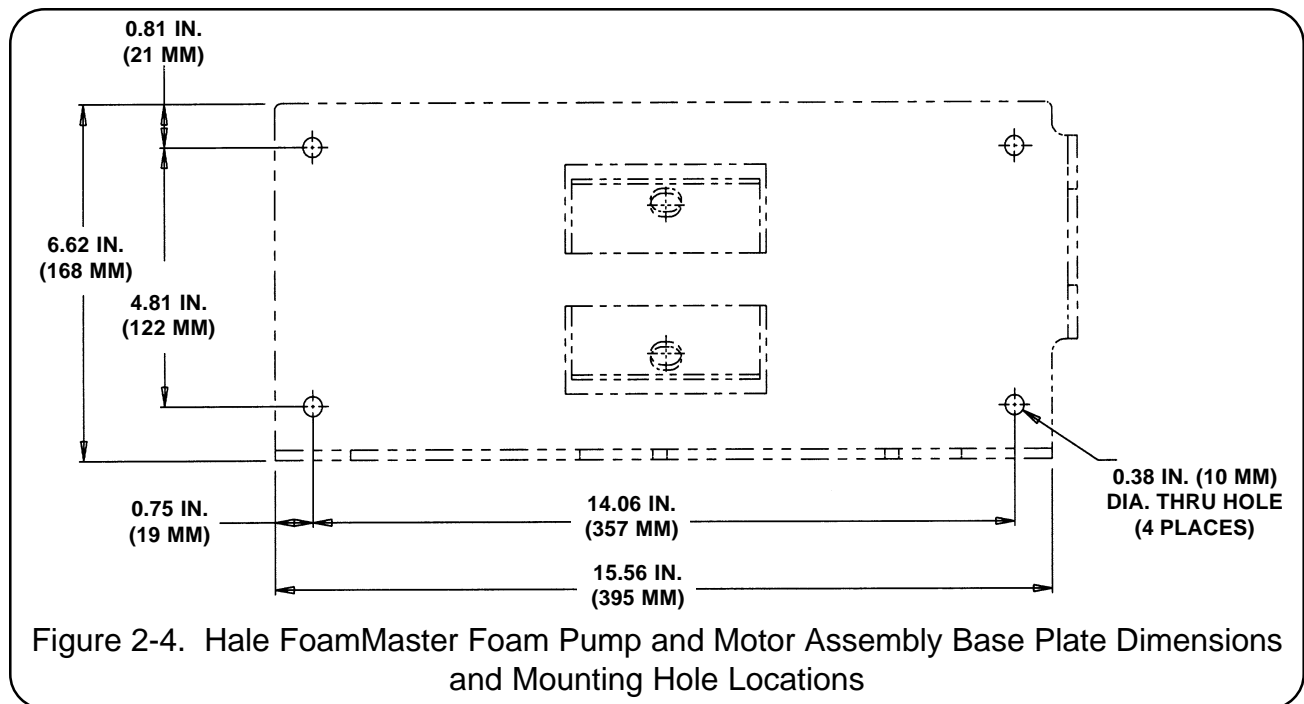

Figure 2-4. Hale FoamMaster Foam Pump and Motor Assembly Base Plate Dimensions and Mounting Hole Locations

PLUMBING COMPONENT INSTALLATION

Hale FoamMaster System plumbing diagrams are located at the end of this manual section. The diagrams provide recommended guidelines for the installation of system components that handle water, foam concentrate and foam solution. The sequence in which the plumbing installation is completed depends on the individual installation.

WATER AND FOAM SOLUTION PLUMBING

When making water and foam solution piping runs use the best industry practices to install this piping. When making threaded pipe connections use a suitable pipe sealing compound at all joints.

OPTIONAL HALE PIPING COMPONENTS

Hale piping components such as 3 inch and 4 inch wafer type check valves, 115 and 2433 series flanges, mini and maxi manifolds, etc. can simplify installation of water and foam solution discharge piping. The arrangement shown in figure 2-5

provides accurate proportioning across a wide range for up to four discharges from the mini manifold. The dual check valve arrangement helps to ensure that no foam concentrate will contaminate the pump water. The Hale mini manifold provides a 1 inch NPT tap for installation of the check valve/injector fitting. The Hale mini manifold and elbow components use 4-³/₈ inch diameter bolt circles and minimize fabrication and pipe work. After installation of the plumbing is complete make sure all pipes, hoses and tubes are supported using the best industry practices.

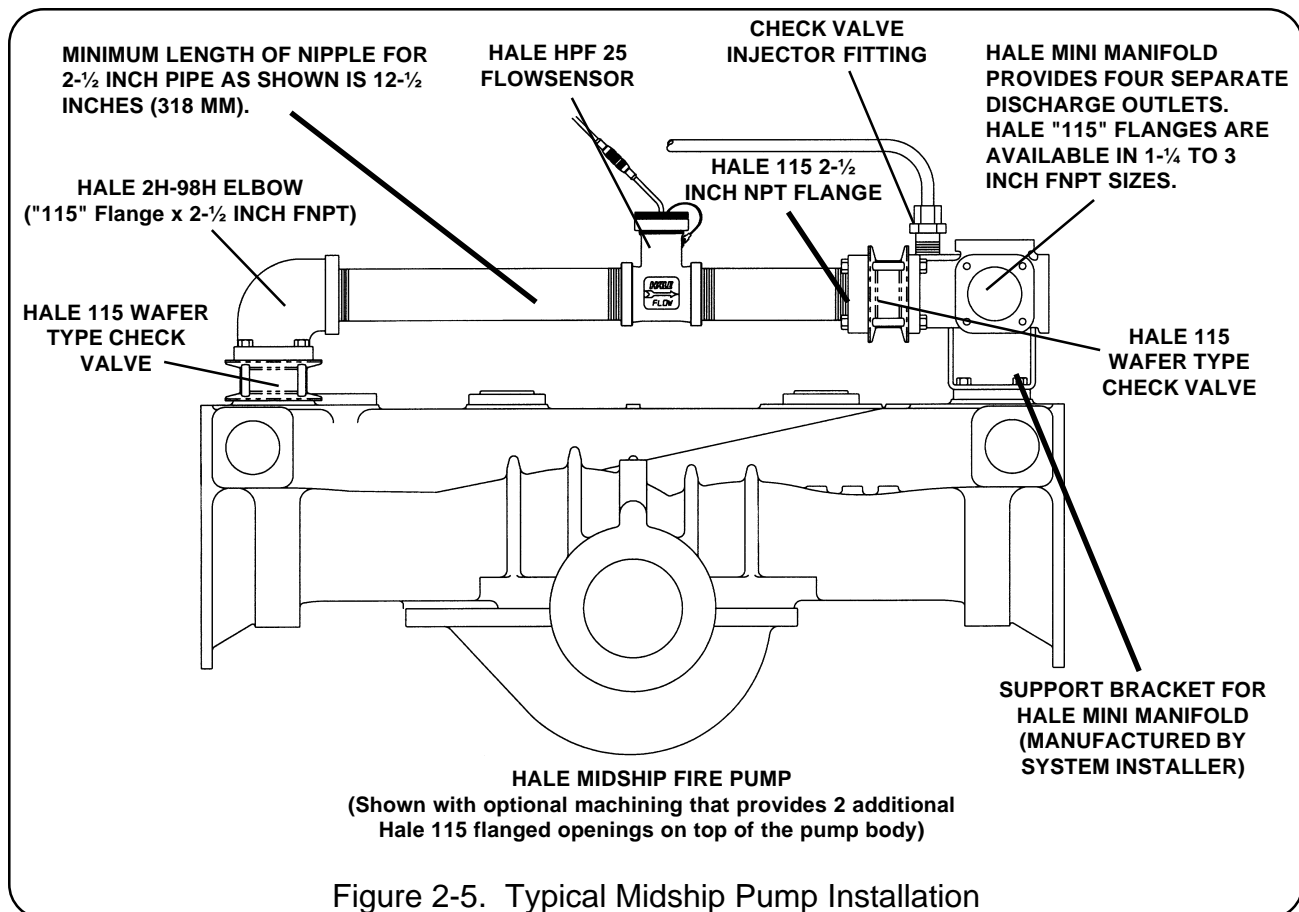

Figure 2-6 shows a suggested installation arrangement using Hale 4 inch check valves, Hale 2433 flanges and 4 inch pipe. A maxi manifold is available from Hale to provide multiple discharges with a common foam injection point using Hale 2433 bolt pattern flanges. The discharges available are similar to those shown for the mini manifold.

WATERWAY CHECK VALVES

Check valves in the waterway, rated at 500 PSI (34 BAR), are required to keep foam solution out of the main pump and allow pump priming without drawing foam into the piping. Using double check valves, separated by at least 8 inches (203 mm) of pipe before the foam injection point, helps ensure that pump and tank water remain uncontaminated.

FLOWSENSOR(S)

Hale FoamMaster HPF flowsensors are specially designed to make inspection and maintenance of the flow sensor easy. The flowsensors are installed in the foam capable discharge piping of the apparatus. In horizontal piping runs, the flowsensors should be mounted as close to upright as possible within the range shown

in figure 2-7. DO NOT let the flowsensors rotate more than 85° in either direction for proper operation.

When selecting flowsensors it is important to consider the minimum and maximum flow requirements during operation, not the piping size being used as one flowsensor MAY NOT cover the entire range of system flows. Refer to the flowsensor selection chart in Section I of this manual for proper flowsensor sizing and installation dimensions.

When a single flowsensor is installed in the Hale FoamMaster system it should be installed in the piping before the foam concentrate injection point.

Some applications will require installation of a Hale mini or maxi manifold to provide a common foam concentrate injection point and the use of multiple flowsensors with Hale foam discharge multiplexing display units.

Other applications may be designed to use a single flowsensor due to space restrictions on the apparatus. In this instance the flowsensor selected can be one pipe size smaller than the piping run (4 inch to 3 inch,

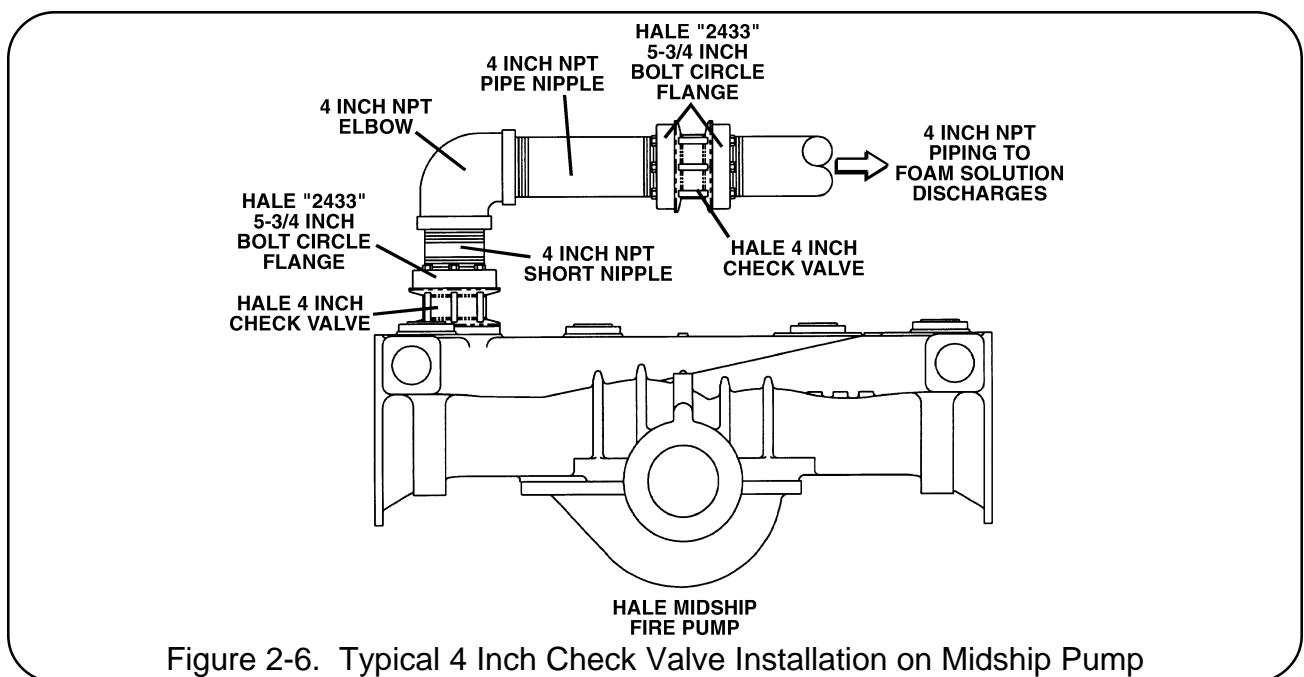

3 inch to 2-½ inch, 2-½ inch to 2 inch or 2 inch to 1-½ inch) to provide for better accuracy at low flow rates. Always refer to the flowsensor selection chart in Section I of this manual for proper flowsensor sizing and installation dimensions. Selection of the next smaller flowsensor permits reducing the straight pipe run the required distance prior to the flowsensor inlet then increasing the pipe size on the flowsensor outlet. In the short length of reduced pipe pressure loss will be minimal and there will be minimal pressure loss through elbows and fittings. Figure 2-8 shows a typical reduced piping run installation.

As an alternative to using reduced pipe size, Hale HPF flowsensor tees are machined with a ring that accepts Victaulic type connection fittings for installation.

Excessive turbulence in the flowsensor may produce unstable and inaccurate flow readings. The length of straight pipe prior to the flowsensor must be sufficient to reduce the turbulence in the pipe. The following installation guidelines will help attain the best readings, and maintain the accuracy of the Hale FoamMaster system.

- a. A minimum **5 times the pipe diameter** of straight run pipe without any fittings is necessary prior to the flowsensor tee (see figure 2-9). Minimum required straight pipe run:

Pipe Size	Minimum Recommended Straight Run Pipe
1-½ in. (38 mm)	7-½ in. (191 mm)
2 in. (50 mm)	10 in. (254 mm)
2-½ in. (64 mm)	12-½ in. (317 mm)
3 in. (76 mm)	15 in. (381 mm)
4 in. (102 mm)	20 in. (508 mm)

- b. The downstream piping length is not as critical but there should be a short length of straight pipe with no fittings or valves immediately after the flowsensor.

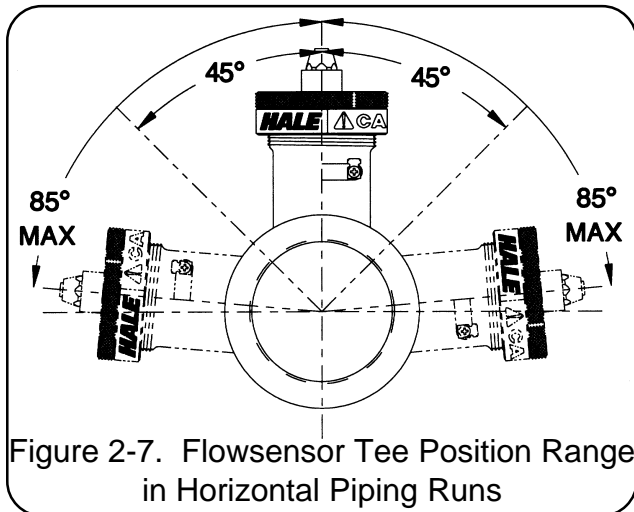

Figure 2-7. Flowsensor Tee Position Range in Horizontal Piping Runs

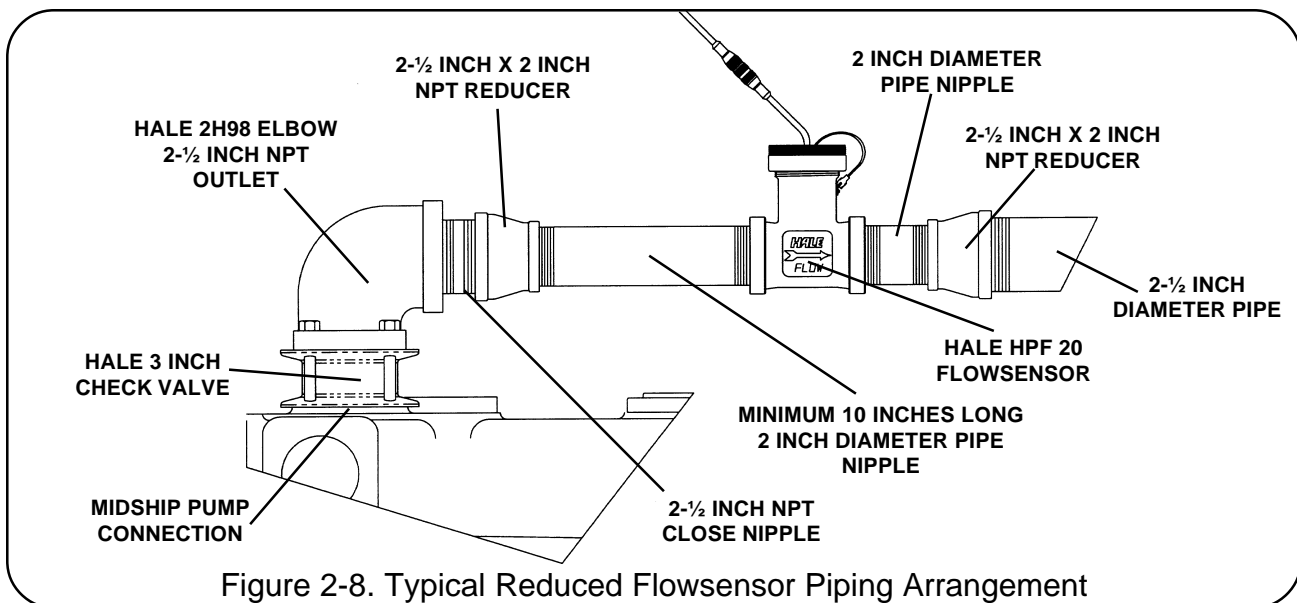
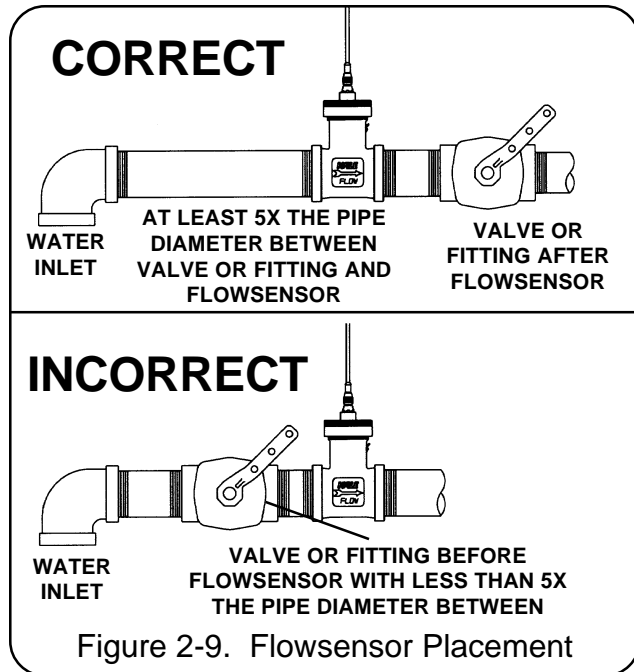
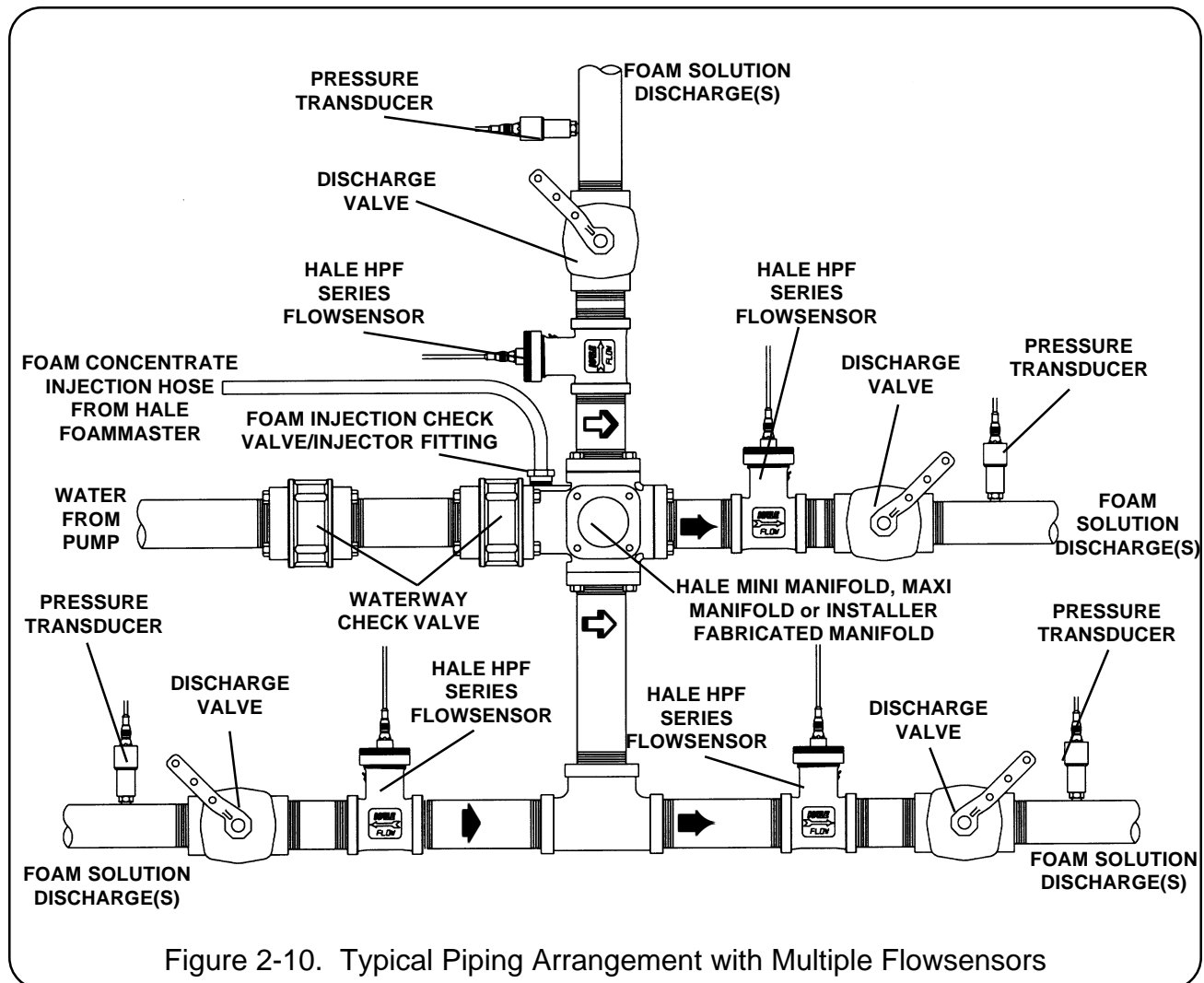

Figure 2-8. Typical Reduced Flowsensor Piping Arrangement



c. Do not mount a flowsensor directly after an elbow or valve. Valves create severe turbulence when they are "gated".

With the use of Hale foam discharge multiplexing display units, 2 to 8 flowsensors and pressure transducers may be monitored simultaneously. The pressure transducers enable replacement of line gauges on foam capable discharge outlets. A single injection point that will supply foam concentrate to all foam capable discharge outlets is required as shown in figure 2-10. Manifolds are available from Hale Products Inc. (Mini manifold; Hale P/N 178-0320-02-0 or Maxi manifold; Hale P/N 178-0420-00-0) for this



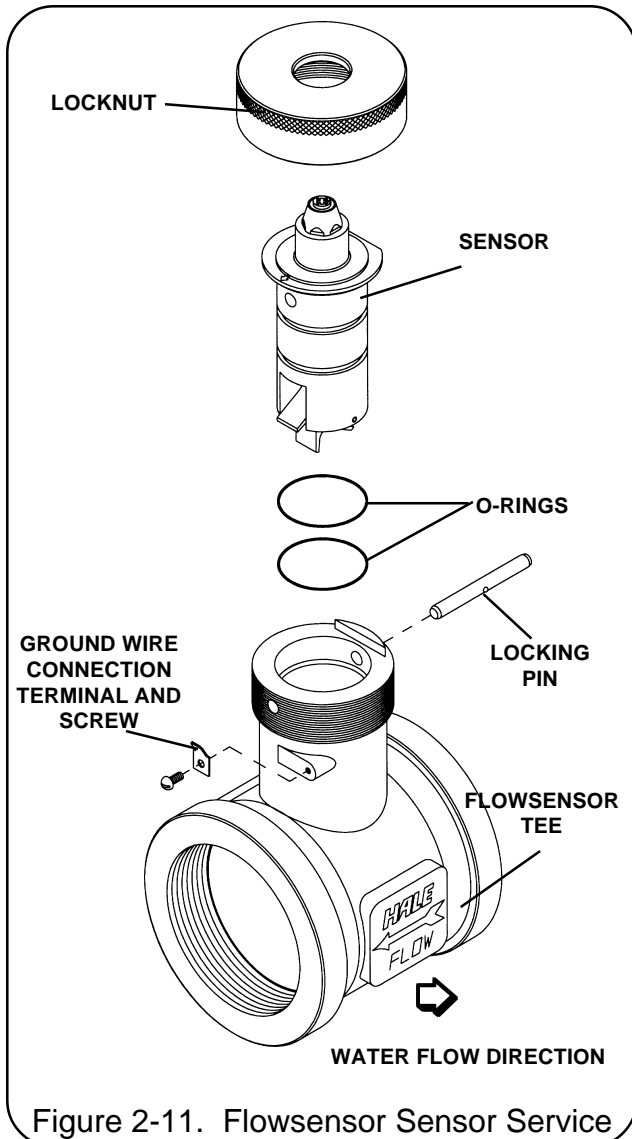

Figure 2-11. Flowsensor Sensor Service

purpose, or a manifold can be designed and constructed by the system installer.

CAUTION: The Hale HPF flowsensor is assembled and tested at the factory. Removal of the sensor from the tee is not necessary or recommended for installation in the system.

It is not necessary to remove the sensor from the flowsensor tee for installation. If removal is necessary refer to figure 2-11 for guidance in disassembly of the flowsensor. After installation of the flowsensor tee is complete the sensor must be inserted back into the tee if it was removed. Make sure the two o-rings are in the grooves on the sensor

before inserting into the tee. After the sensor is seated in the flowsensor tee it must be locked in place using the locking pin and locknut provided. The locknut must be tightened handtight only. (See figure 2-11)

FOAM PUMP FLUSH SYSTEM

When dual foam tanks are installed on the apparatus, flushing water must be provided to flush the system of foam concentrate after use of some foam concentrate types to prevent possible reactions. The Hale ADT and Hale MDT II each have provisions for connecting flushing water to the foam concentrate injection system.

If a single foam concentrate tank system is installed on the apparatus the Hale MST provides a selector valve and gives the system flush capabilities for NFPA compliance. A fitting provided on the Hale MST makes connection of flushing water simple.

When the Hale FoamMaster is installed with the "no tank" option the system installer must provide flushing water supply to comply with NFPA standards.

Flushing water hose should have a minimum of ½ inch (12 mm) inside diameter and be capable of withstanding the maximum fire pump discharge pressure, 500 PSI (34 BAR) minimum. The flush water supply should be provided from one of the pressure taps on the discharge of the fire pump. Flush water thread connections on the ADT are ½ inch NPT and on the Hale MDT II and Hale MST they are ¼ inch NPT. The system installer must provide proper fittings for these connections.

FOAM CONCENTRATE PLUMBING

Foam concentrate plumbing consists of the foam concentrate suction hose, foam strainer, foam concentrate discharge hose and check valve/injector fitting.

CAUTION: Make sure the foam tank and foam concentrate suction hoses are

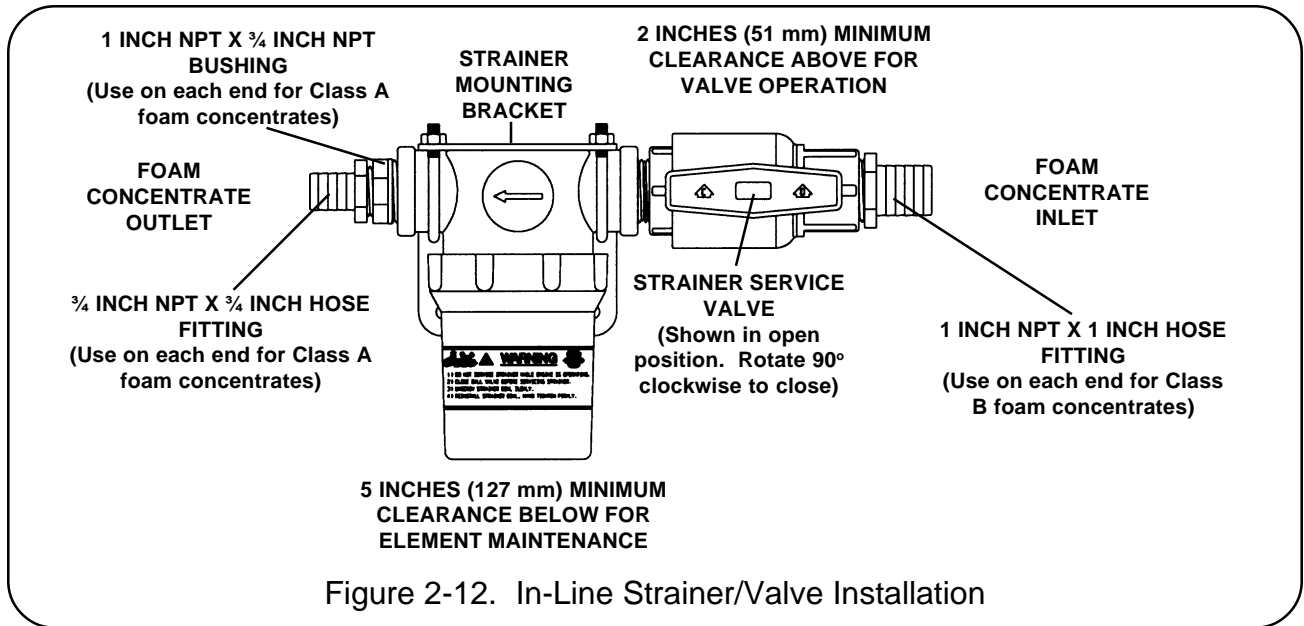

clean before making final connection to foam pump. If necessary flush tank and hoses prior to making connection.

FOAM STRAINER IN-LINE STRAINER/VALVE ASSEMBLY

CAUTION: The in-line strainer/valve assembly is a low pressure device and WILL NOT withstand flushing water pressure. When installing the in-line strainer in systems equipped with Hale MDT II or Hale MST make sure the in-line strainer/valve assembly is in the hose on the inlet side of the valve. If the strainer will be subject to flushing water pressure, use Hale FS series strainers.

The in-line strainer/valve assembly has 1 inch NPT female threaded ports. Fittings are supplied for connection of 3/4 inch (19 mm) or 1 inch (25 mm) inside diameter hose depending on the viscosity of foam concentrates used. (See figure 2-12) Generally 3/4 inch inside diameter hose will be used for Class A foam and 1 inch inside diameter hose will be used for Class B foams. A bracket is included with the in-line strainer/valve assembly to permit installation on the apparatus.

The hose from the foam tank(s) to the strainer should have adequate wall stiffness to withstand the vacuum of the foam pump while it is operating (23 inches (584 mm) Hg and 50 PSI (3 BAR)) (Kuriyama, Kuri-tec K-7130 series or equal).

The following procedures are provided for installation of the in-line strainer/valve assembly:

1. Choose a location on the apparatus

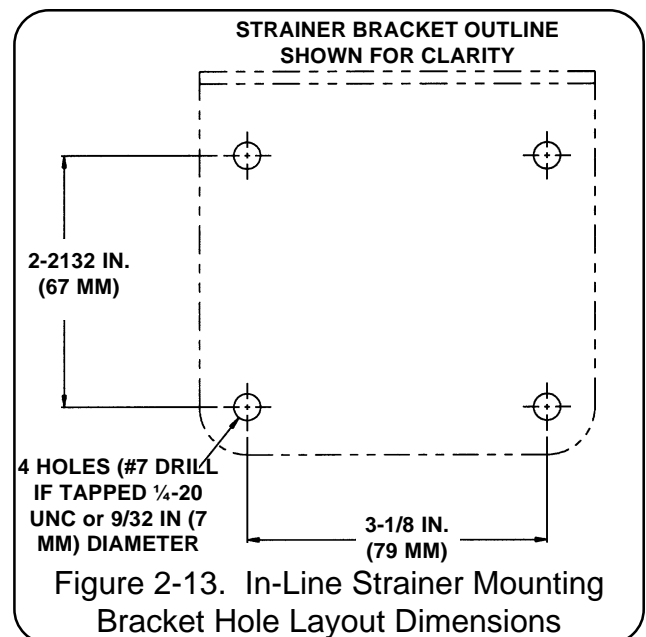

that allows gravity feed from the foam tank to the strainer inlet and from the strainer outlet to the foam pump suction connection.

NOTE: When selecting the strainer location make sure there is sufficient space below the strainer for removal of the strainer basket and screen for cleaning. A minimum of 5 inches (127 mm) is required for this purpose. Also make sure there is at least 2 inches (51 mm) above the strainer assembly to permit operation of the service valve. (Refer to figure 2-12)

2. Refer to the diagram in figure 2-13 and mark 4 holes for mounting the foam strainer bracket. The holes must be drilled to accommodate 1/4-20 UNC screws. The holes can either be tapped (#7 drill for 1/4-20 UNC tap) or drill large enough to use screws, nuts and washers (9/32 inch (7 mm) diameter) to secure the bracket to the apparatus. Secure the bracket and strainer/valve assembly to the apparatus.
3. Select the appropriate fittings from the bag attached to the strainer assembly. Two of each fitting are included with the strainer assembly.

When using class A or low viscosity class B foam concentrates use the 1 inch NPT x 3/4 inch NPT bushings and the 3/4 inch NPT x 3/4 inch hose fittings in each end of the strainer/valve assembly.

Class B foam concentrates generally require the use of the 1 inch NPT x 1 inch hose fittings.

Before assembly coat all fitting threads with Permatex #80724 (or equal) plastic pipe thread sealant. Install the fittings into the strainer/valve assembly ends and tighten securely.

4. Install the clear plastic hose from the foam tank outlet to the inlet of the strainer/valve assembly. The inlet of the strainer/valve assembly is on the valve end. Wetting the ends of the hose and fittings will help ease installation on the hose fittings.

CAUTION: Make sure the foam tank and foam concentrate suction hoses are clean before making final connection to foam pump. If necessary flush tank and hoses prior to making connection.

5. Install the clear plastic hose from the in-line strainer/valve assembly outlet to the inlet of the Hale MDT II, Hale MST or foam concentrate pump.

FS SERIES STRAINER

When a pressurized water flush is provided to the strainer from one of the discharges the use of Hale FS series strainers is required. The plumbing exposed to the flush water pressure must be rated at or above the operating pressure of all other discharge plumbing components. (500 PSI (34 BAR) minimum)

The following procedures are provided for installation of FS series strainers:

1. Choose a location on the apparatus that allows gravity feed from the foam tank to the strainer inlet and from the strainer outlet to the foam pump suction connection.

NOTE: When selecting the strainer location make sure there is sufficient space behind the pump panel to permit attaching hoses and fittings. Make sure

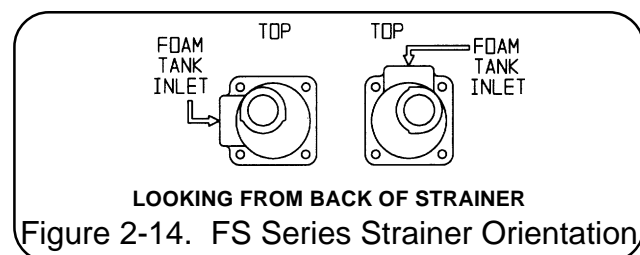

Figure 2-14. FS Series Strainer Orientation

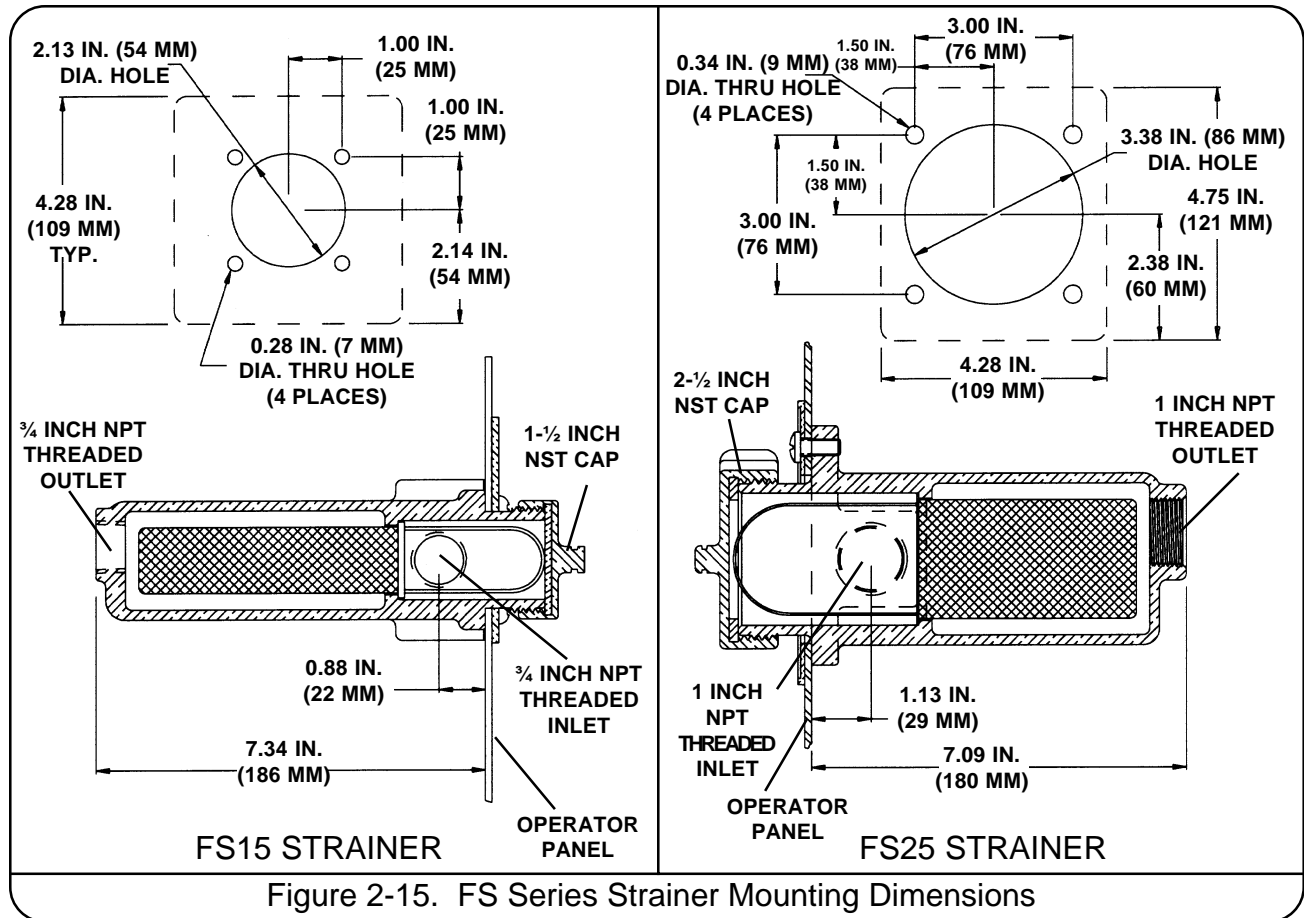

Figure 2-15. FS Series Strainer Mounting Dimensions

the inlet connection port is oriented as shown in figure 2-14 when installing the FS series strainer.

2. Remove the strainer cap, mounting screws and nameplate from the strainer assembly.
3. Using the nameplate as a guide, or refer to the diagrams in figure 2-15, mark holes for mounting the foam strainer. The holes for the FS15 strainer mounting screws are 9/32 inch (7 mm) and the holes for FS25 strainer screws are 11/32 inch (9 mm) diameter. Additionally a hole of sufficient size for the cap threads to clear the panel is required. (FS15 strainer 2.13 inches (54 mm) and FS25 strainer 3.38 inches (86 mm))
4. Select appropriate fittings for attachment of the hoses to the strainer. The fittings and hoses chosen must be

capable of withstanding the vacuum generated by the foam pump (23 inches (584 mm) Hg) and the maximum flushing water pressure (500 PSI (34 BAR)).

When using an FS15 strainer use 3/4 inch NPT x 3/4 inch hose fittings.

When using an FS25 strainer use 1 inch NPT x 1 inch hose fittings.

Before assembly coat all fitting threads with a suitable thread sealant. Install the fittings into the strainer and tighten securely.

5. Make sure the strainer is oriented as shown in figure 2-14 and secure the strainer body and nameplate to the apparatus with the screws provided. Install the cap on the strainer.

6. Install the hose from the foam tank outlet to the inlet of the strainer. The inlet of the strainer is closer to the operator panel and is oriented as shown in figure 2-14. Wetting the ends of the hose and fittings will help ease installation on the hose fittings.

CAUTION: Make sure the foam tank and foam concentrate suction hoses are clean before making final connection to foam pump. If necessary flush tank and hoses prior to making connection.

7. Install the hose from the strainer outlet to the inlet of the Hale FoamMaster foam pump or selector valve.

CHECK VALVE/INJECTOR FITTING

The Hale check valve/injector fitting supplied with the Hale FoamMaster system meets NFPA requirements for a non-return device in the foam injection system to prevent back flow of water into the foam concentrate tank. When properly installed the brass and stainless steel construction check valve/injector fitting ensures foam concentrate is injected into the center of the water flow for better mixing.

NOTE: Always position the check valve/injector fitting at a horizontal or higher angle to allow water to drain away from the fitting (see figure 2-16). This will avoid sediment deposits or the formation of an ice plug.

The check valve/injector fitting **MUST** be mounted in a location that is common to all discharges which require foam concentrate (see figure 2-18). The Hale FoamMaster system does not permit a separate injection point for each foam capable discharge. Even though multiple flowsensors and pressure sensors are installed on a particular system, the check valve/injector fitting must be installed before these components at the inlet to their common manifold (refer to figure 2-10).

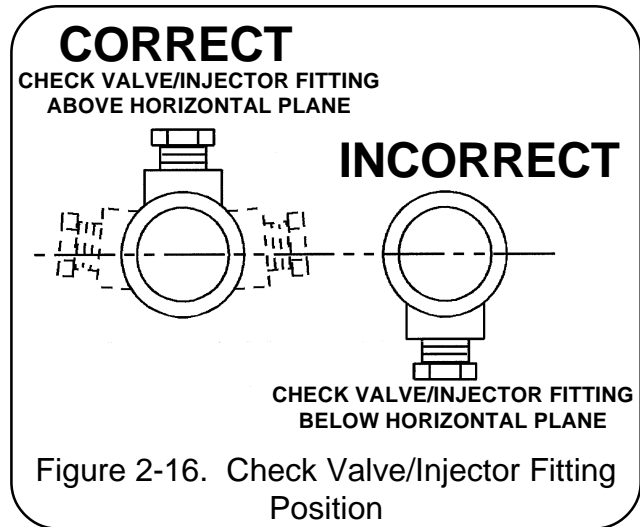

The check valve/injector fitting has 1 inch NPT threads on the outside to fit into the 1 inch NPT threaded connection on the Hale mini manifold, maxi manifold, a pipe tee or a 1 inch NPT weld fitting installed in the discharge piping of the fire pump (see figure 2-17). The inlet connection of the check valve/injector fitting has ½ inch NPT female threads.

FOAM CONCENTRATE INJECTION HOSE

Connect hose from the foam pump inject port (see figure 2-19) to the inlet of the check valve injector fitting. The hose and fittings from the INJECT port to the check valve injector fitting should have minimum

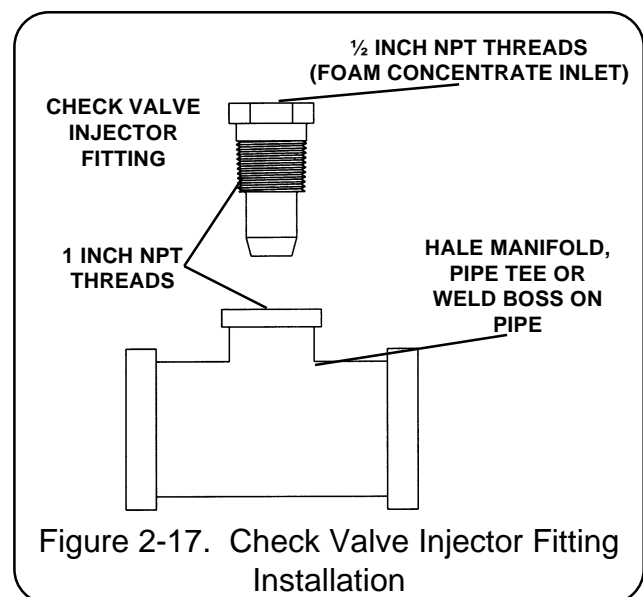

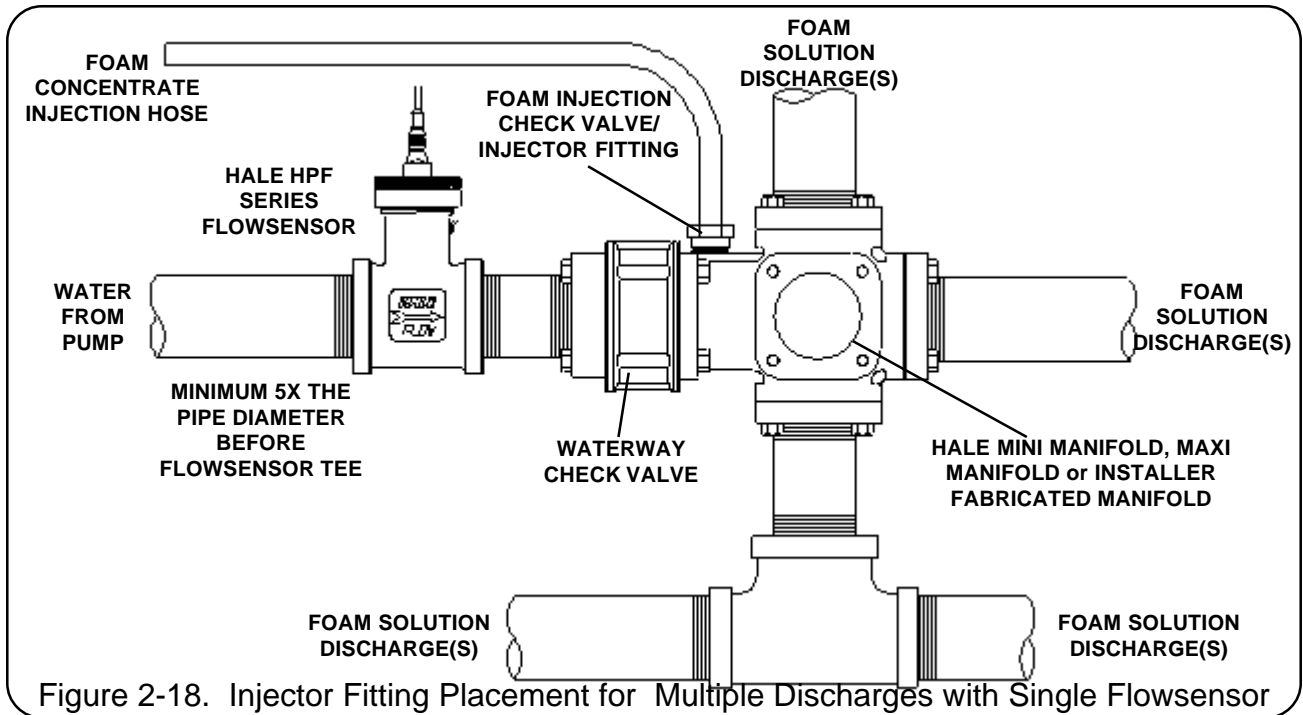

Figure 2-18. Injector Fitting Placement for Multiple Discharges with Single Flowsensor

½ inch (13 mm) inside diameter and be rated at 500 PSI (34 BAR) working pressure (Aeroquip 2580-10 or equal).

BYPASS HOSE CONNECTION

A bypass port is provided on the discharge side of the Hale ADT or a bypass valve is mounted on the discharge of the foam pump when the ADT option is not installed. The bypass handle shall be accessible by

the pump operator during normal operations.

The bypass valve is a 3-way directional valve that selects where the output of the foam pump will go. Determine which port is the INJECT port (see figure 2-19) and which port is the BYPASS port. The INJECT port is identified on the bypass valve placard. Look at the ports as you move the handle, the flow should go from the center port to

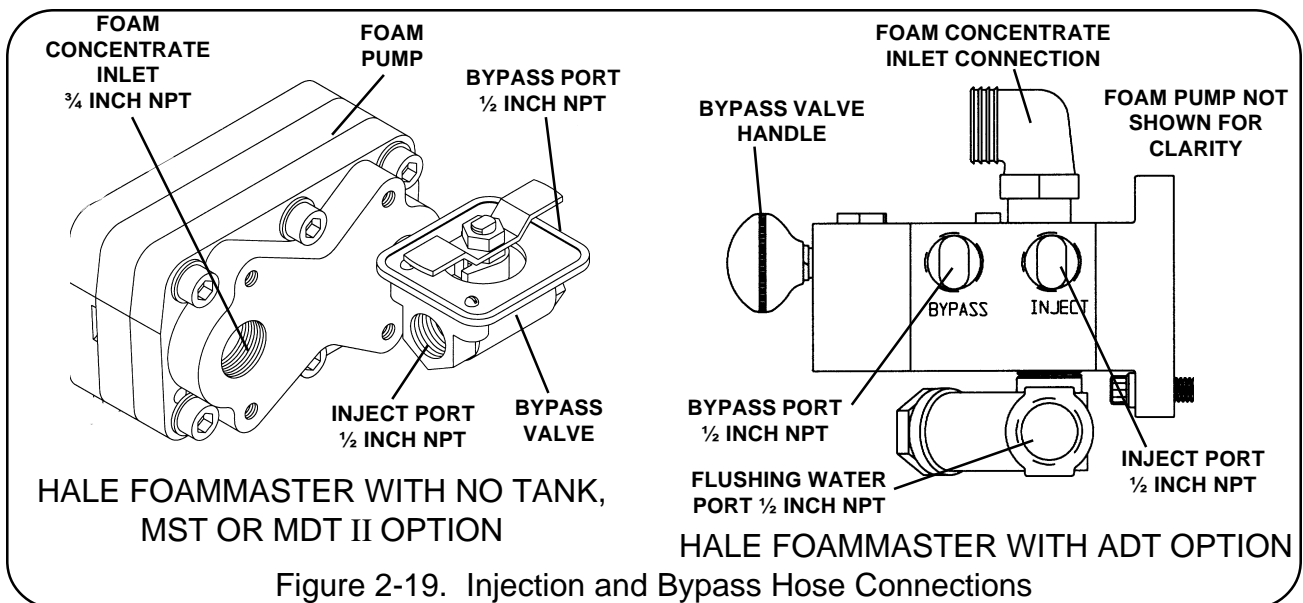

Figure 2-19. Injection and Bypass Hose Connections

each of the other ports. The bypass port on the ADT is identified by a label above the port.

Bypass hose connections are ½ inch NPT threads. Hose fittings compatible with all foam concentrates to be used must be provided. The hose from the BYPASS port is plumbed to the atmosphere and should not receive high pressures. This hose is used for calibrating the foam pump, pumping the concentrate into a container to empty the foam tank or to assist in priming of the foam pump. The hose from the BYPASS port must be long enough to reach a container outside the truck. This hose must be coiled for storage when not in use.

If the handle or placard is removed from the bypass valve for repairs or to facilitate remote mounting make sure they are installed on the valve correctly. Make sure the tang on the handle engages the cast stops as shown in figure 2-20.

ADT AIR CONNECTIONS

If the ADT option is used, install the operating switch and indicator light placard for the ADT on the apparatus operator panel. A mounting cutout diagram is provided as figure 2-21

After mounting the placard assembly install the air hoses from the ADT to the placard assembly. Make sure proper connections are made at the placard assembly as indicated in figure 2-22. A color coded decal attached to the ADT valve assembly along with an optional color coded air hose harness simplifies air hose connections. If the optional air hose harness is not used ¼ inch inside diameter air brake tubing can be substituted. Make sure the air brake tubing selected has the proper DOT approval. When cutting the air harness or air brake tubing to size make sure the ends are square using a tubing cutter or razor knife.

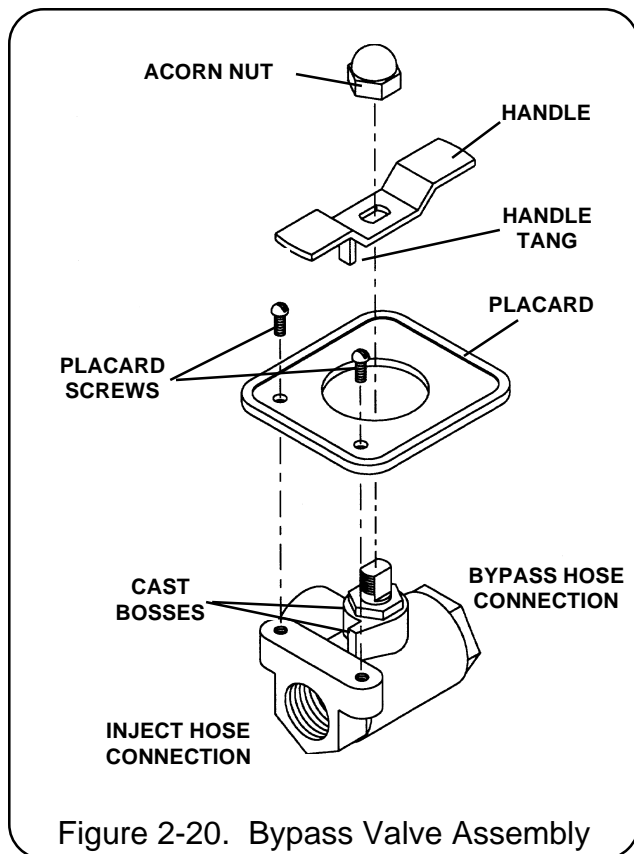

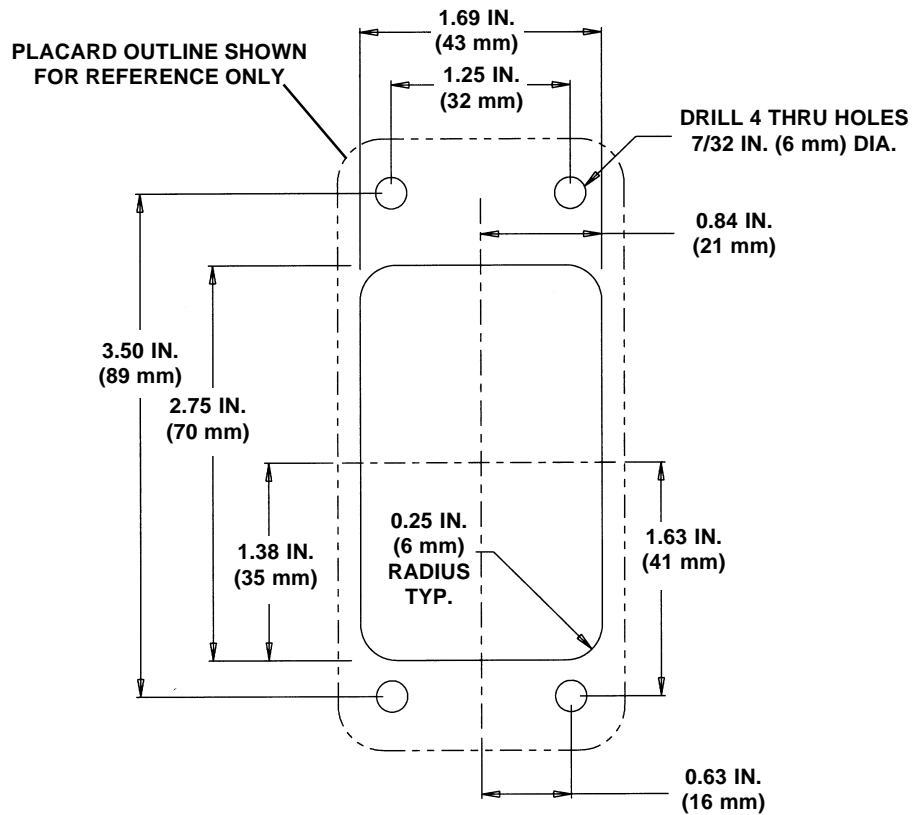

Figure 2-21. ADT Panel Placard Panel Cutout and Hole Dimensions

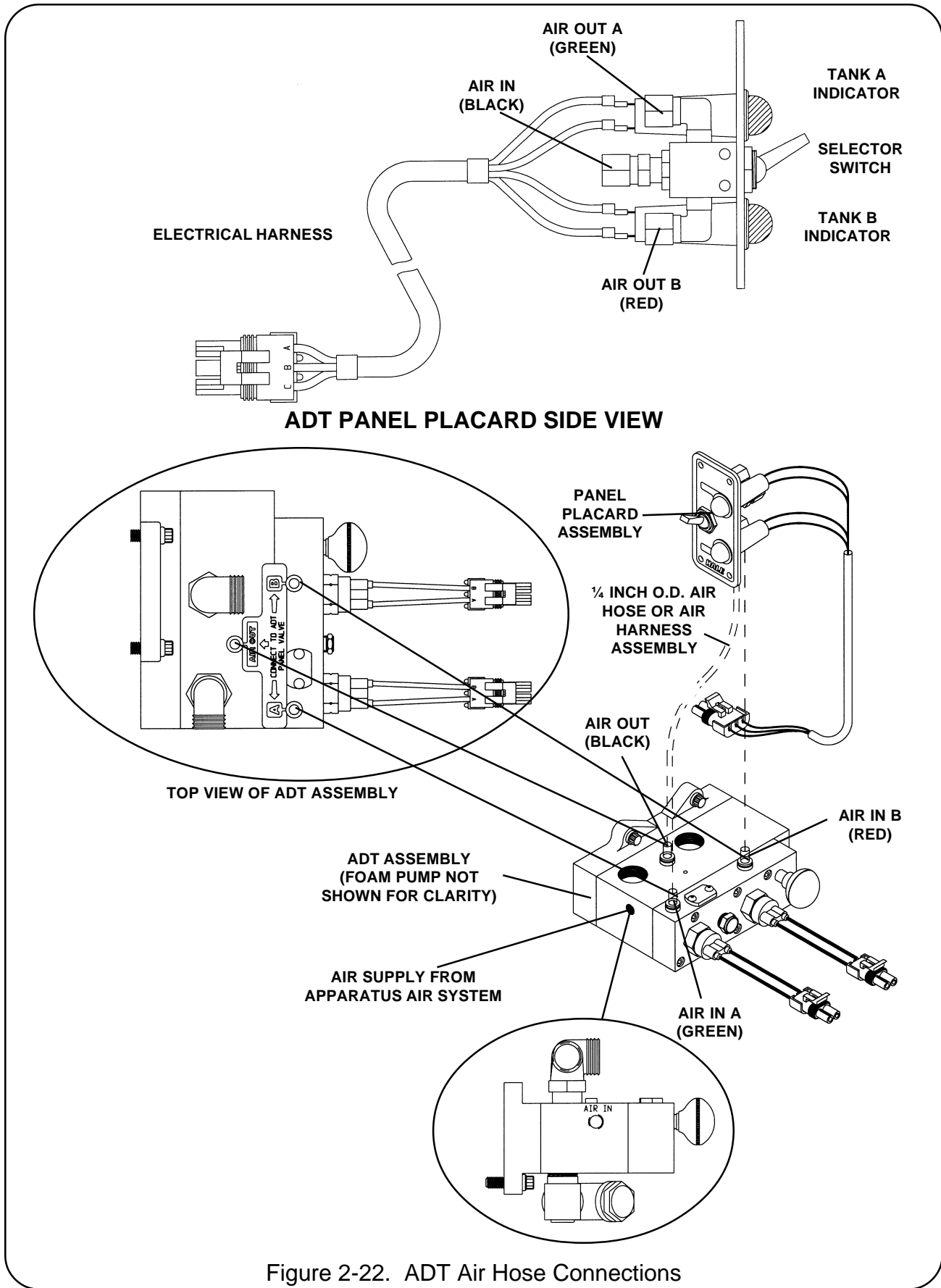
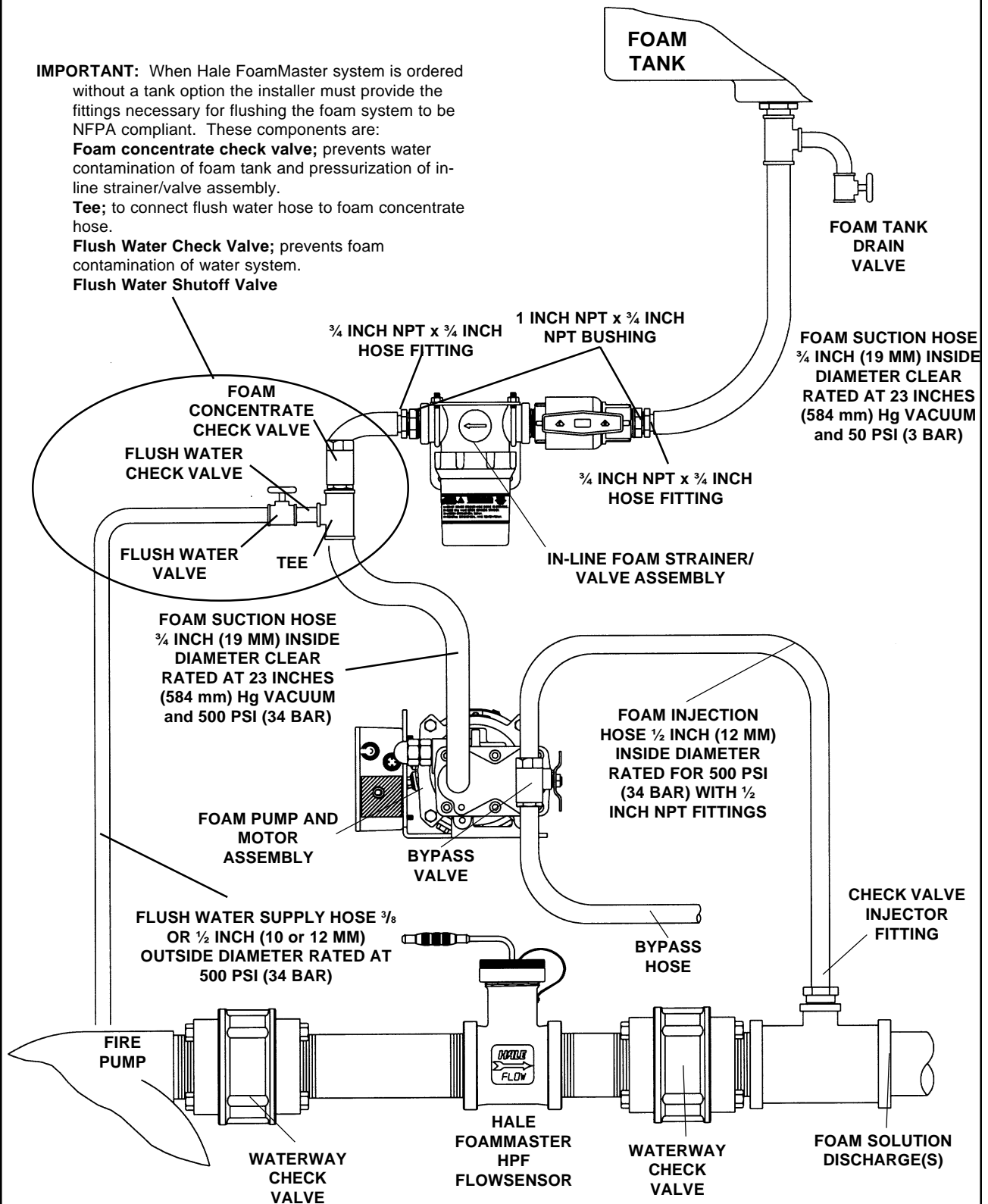

Figure 2-22. ADT Air Hose Connections

SYSTEM PLUMBING DIAGRAMS

The following pages contain Hale FoamMaster system plumbing diagrams for the various system configurations. Due to variations in apparatus configuration and individual component locations, lengths of hoses and piping is not provided. The material described and component sizes are those which will provide optimum performance of a Hale FoamMaster system. These diagrams are intended as guidelines to assist the system installer with selection of hoses and fittings along with the connections required.

IMPORTANT: When Hale FoamMaster system is ordered without a tank option the installer must provide the fittings necessary for flushing the foam system to be NFPA compliant. These components are:
Foam concentrate check valve; prevents water contamination of foam tank and pressurization of in-line strainer/valve assembly.
Tee; to connect flush water hose to foam concentrate hose.
Flush Water Check Valve; prevents foam contamination of water system.
Flush Water Shutoff Valve



Hale FoamMaster System Plumbing Diagram with Single Foam Concentrate Tank

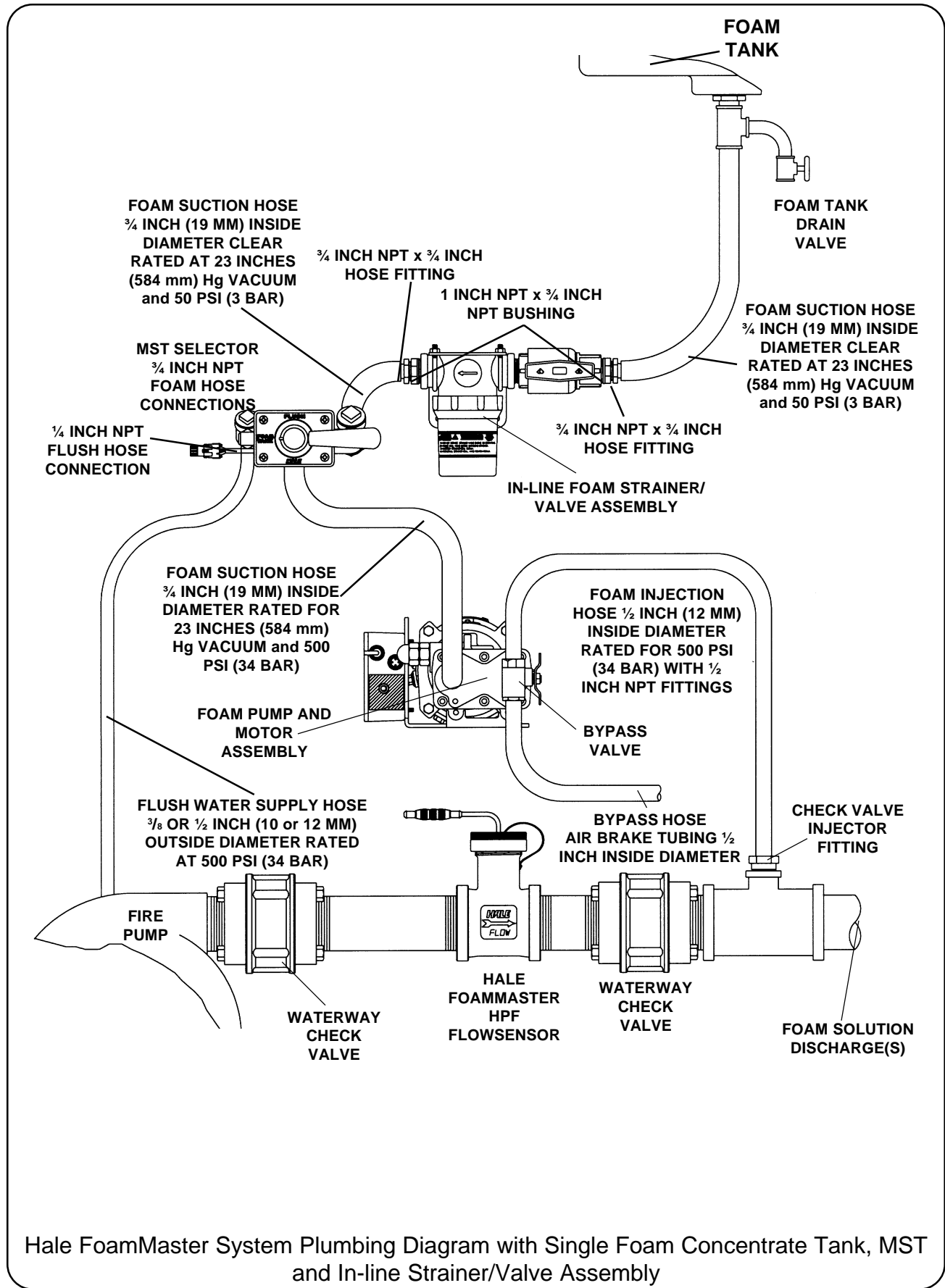

Hale FoamMaster System Plumbing Diagram with Single Foam Concentrate Tank, MST and In-line Strainer/Valve Assembly

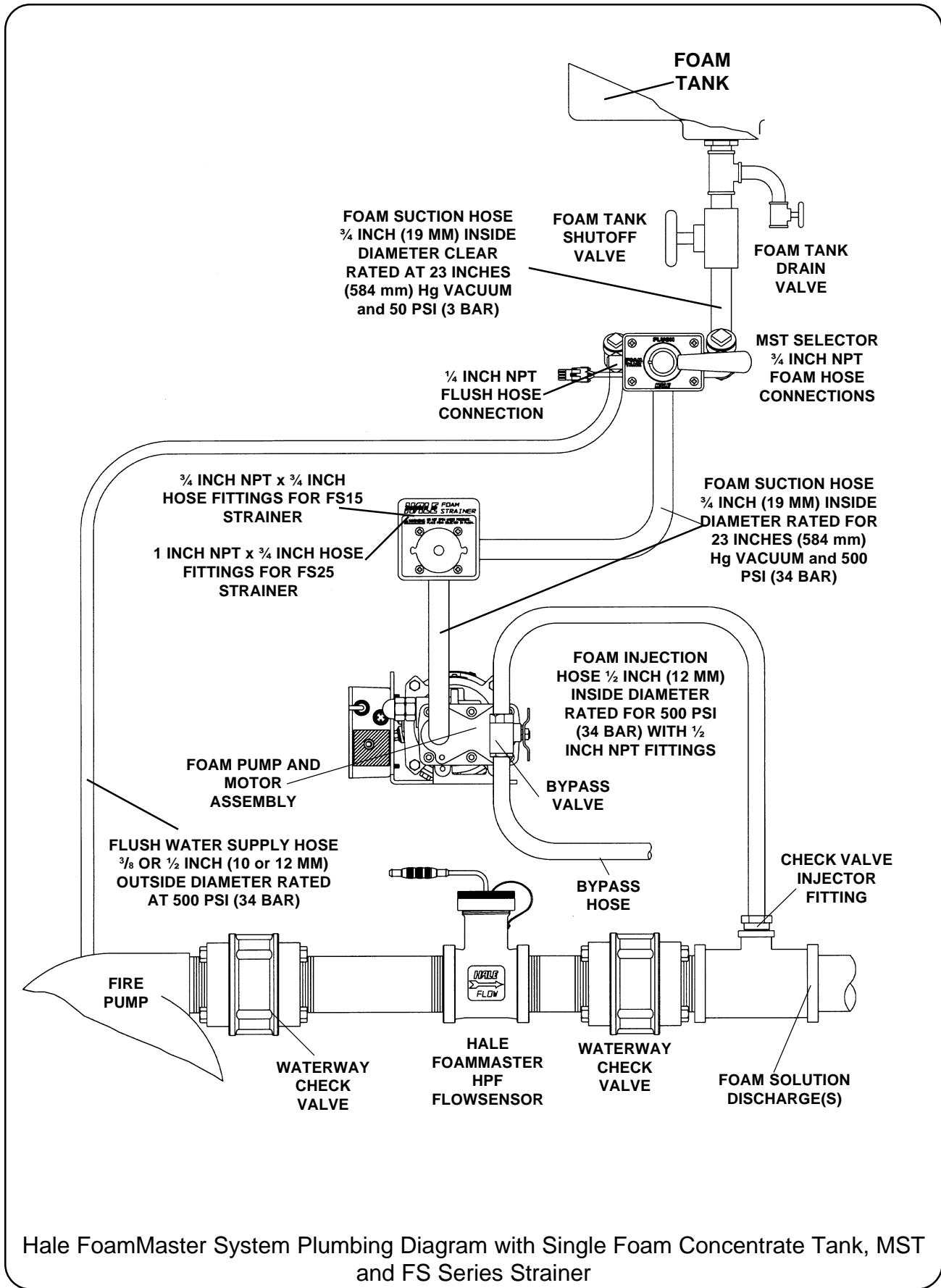

Hale FoamMaster System Plumbing Diagram with Single Foam Concentrate Tank, MST and FS Series Strainer

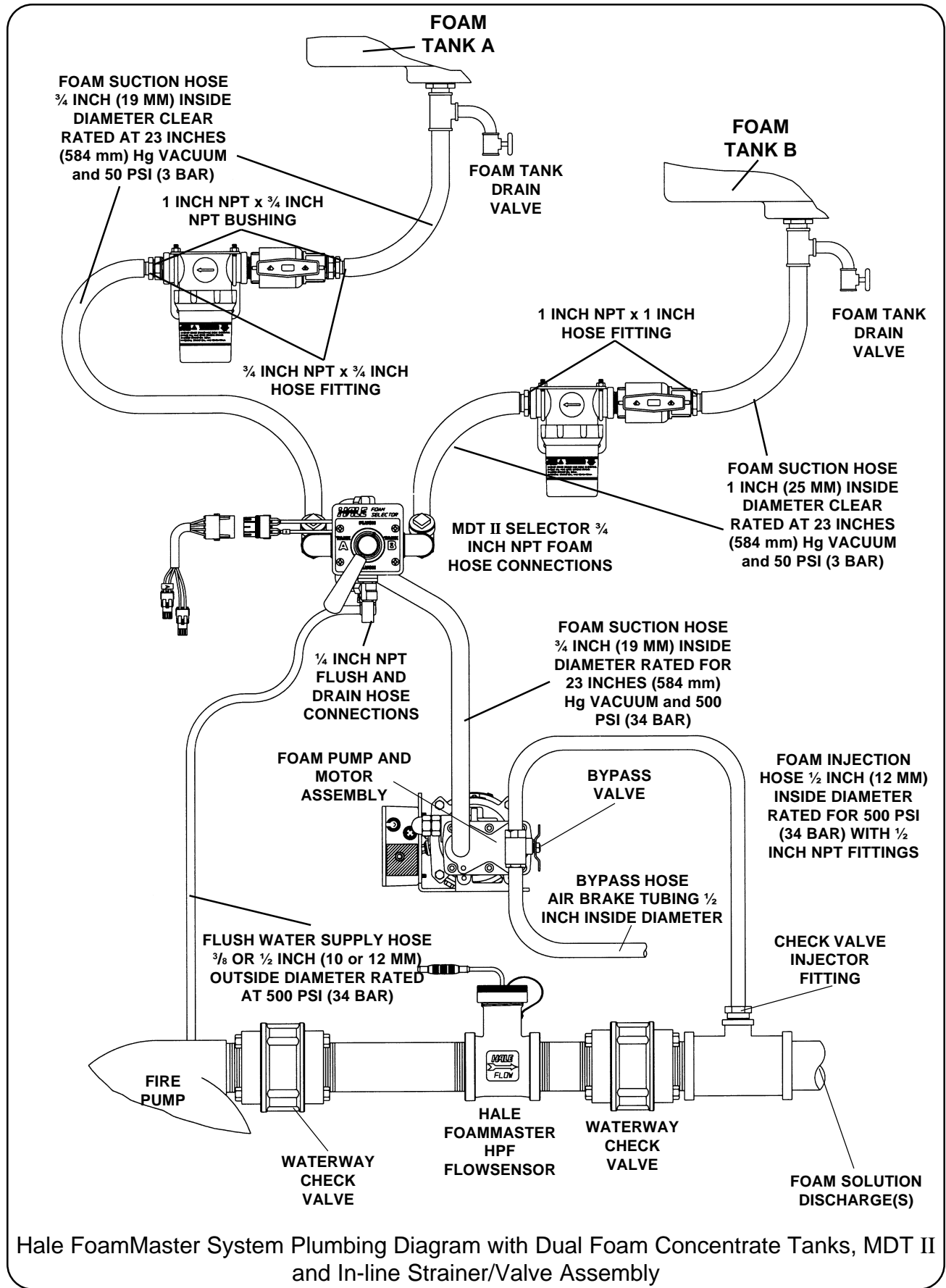

Hale FoamMaster System Plumbing Diagram with Dual Foam Concentrate Tanks, MDT II and In-line Strainer/Valve Assembly

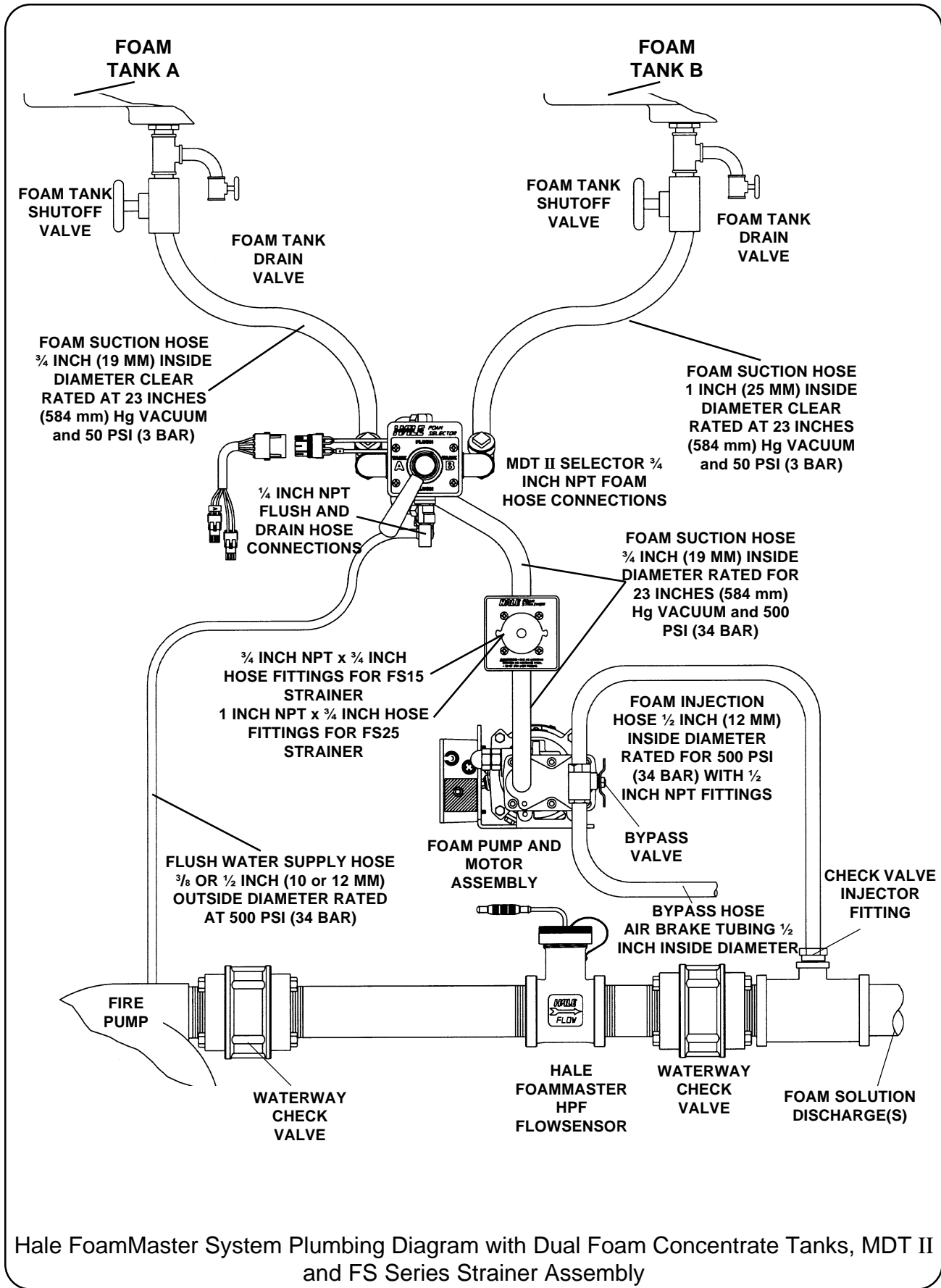

Hale FoamMaster System Plumbing Diagram with Dual Foam Concentrate Tanks, MDT II and FS Series Strainer Assembly

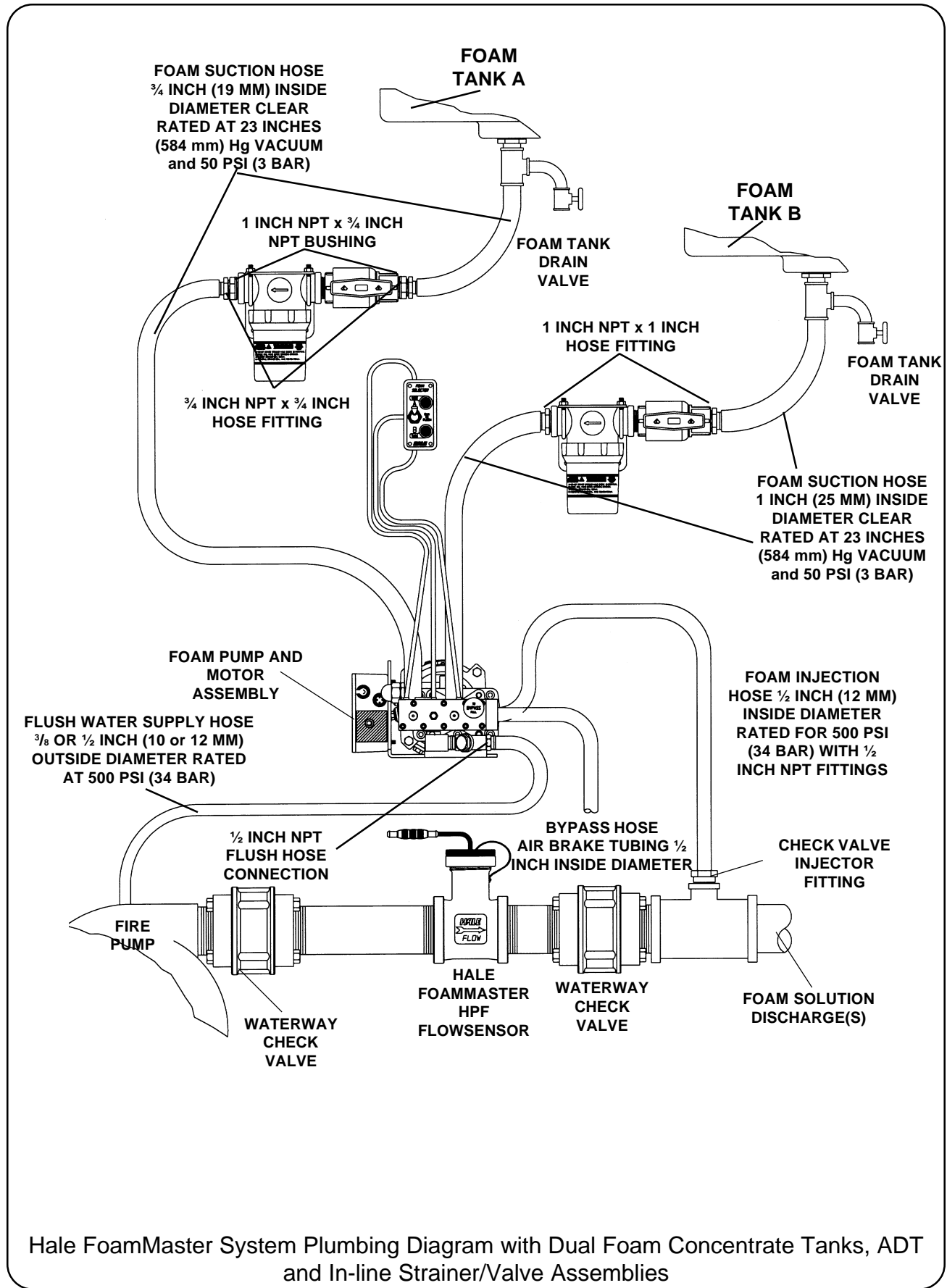

Hale FoamMaster System Plumbing Diagram with Dual Foam Concentrate Tanks, ADT and In-line Strainer/Valve Assemblies

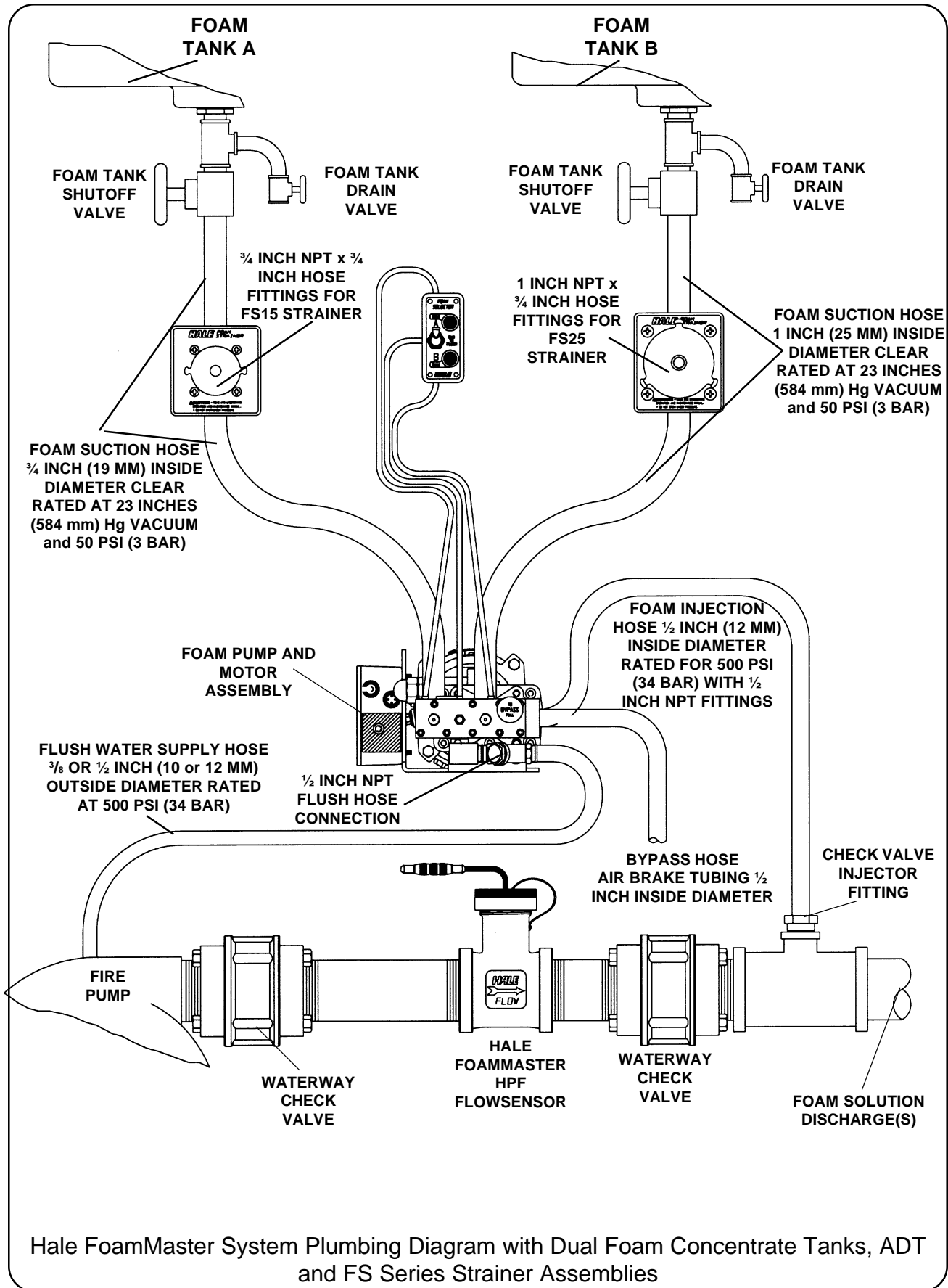

ELECTRICAL INSTALLATION

ELECTRICAL CONNECTIONS

Complete system electrical diagrams are provided at the end of this manual section. Refer to these diagrams for proper hookup of each of the electrical components. The Hale FoamMaster system is designed to be installed with a minimum of electrical connections. Complete electrically shielded cables are provided with each Hale FoamMaster system to make the flowsensor, control unit and distribution box connections. The system installer must supply primary power wire, low tank level sensor wire and flat braided ground straps.

ELECTRICAL INSTALLATION CAUTIONS

- To prevent system damage or electrical shock the main power supply wire will be the last connection made to the Hale FoamMaster distribution box.
- The cables provided with each Hale FoamMaster system are shielded assemblies. Never attempt to shorten or lengthen the cables. If necessary order longer or shorter cables from Hale Products to suit the particular installation.
- The cables are indexed so they only go in the correct receptacle and they can only go in one way. When making cable connections DO NOT force mismatched connections as damage can result in improper system operation.
- The system can only perform when the electrical connections are sound, so make sure each one is correct.
- Hale FoamMaster systems are designed for use on direct current, negative ground apparatus electrical systems only.
- Do not mount radio transmitter or transmitter cables in direct or close contact with the Hale FoamMaster unit.
- Before connecting the cables inspect the o-ring seal in the female connector. If the seal washer is missing or damaged, water can enter the connector causing corrosion of the pins and terminals resulting in possible system failure.
- The cables shipped with each Hale FoamMaster system are tested at the factory with that unit. Improper handling and forcing connections can damage these cables which could result in other system damage.
- The ground strap must be a minimum of 1-¼ inches (32 mm) wide and no longer than 18 inches (457 mm). A longer ground strap must be wider or a double thickness strap must be used. Make sure the ground strap is attached to the chassis frame. Grounding to the body IS NOT acceptable.
- Always disconnect the power cable, ground straps, electrical wires and cables from the control unit or other Hale FoamMaster equipment before electric arc welding at any point on the apparatus. Failure to do so will result in a power surge through the unit that could cause irreparable damage.
- There are no user servicable parts inside Hale FoamMaster system electrical/ electronic components. Opening of these components (distribution box, control unit, foam discharge multiplexing display unit) will void warranty.
- When an inline current shunt ammeter is installed on the apparatus or the Hale FoamMaster is used with Multiplexing Display Units with multiple water flow meters it is necessary to install a FoamMaster power filter kit (Hale P/N 546-1870-00-0) on the Hale FoamMaster foam pump.

CONTROL UNIT

The control unit mounts in the operator panel of the apparatus. The cutout required in the operator panel is a 3-¾ inch (95 mm) diameter hole. The display is secured with four #10 socket head screws in the four holes in the face (See figure 2-23 for mounting dimensions). The display requires 7 inches (178 mm) minimum clearance from the back of the operator panel to allow proper connection of cables. Once the control unit is mounted on the operator panel, connect the 6 pin control cable from the male distribution box connection (figure 2-24) to the 6 pin female connector on the back of the control unit (figure 2-25). A decal on the distribution box identifies each cable connection (see figure 2-24).

NOTE: Ensure that the panel where the control unit is mounted has an adequate ground. For stainless steel and vinyl coated panels a ground strap ½ inch (12 mm) wide must be attached from one of the four screws holding the control unit in place to the frame of the fire truck to ensure adequate grounding.

FLOWSENSOR CONNECTIONS

If a single Hale FoamMaster paddlewheel

type flowsensor is used, a cable is supplied which connects from the 4 pin connector (refer to figure 2-11) or pigtail on the sensor to the male 4 pin connector on the control unit (see figure 2-25).

FOAM DISCHARGE MULTIPLEXING DISPLAY UNITS

See foam discharge multiplexing system manual (P/N 029-0020-36-0) for multiple Hale FoamMaster Flowsensor installations. Figure 2-26 shows the connection of the flowsensors, pressure transducers and display unit with the control unit for reference only.

NOTE: When an inline current shunt ammeter is installed on the apparatus or the Hale FoamMaster is used with Multiplexing Display Units with multiple water flow meters it is necessary to install a FoamMaster power filter kit (Hale P/N 546-1870-00-0) on the Hale FoamMaster foam pump.

FOAM TANK LOW LEVEL SENSOR INSTALLATION

The foam tank low tank level sensor(s) must be installed and wired to monitor foam concentrate level. Mount a low tank level

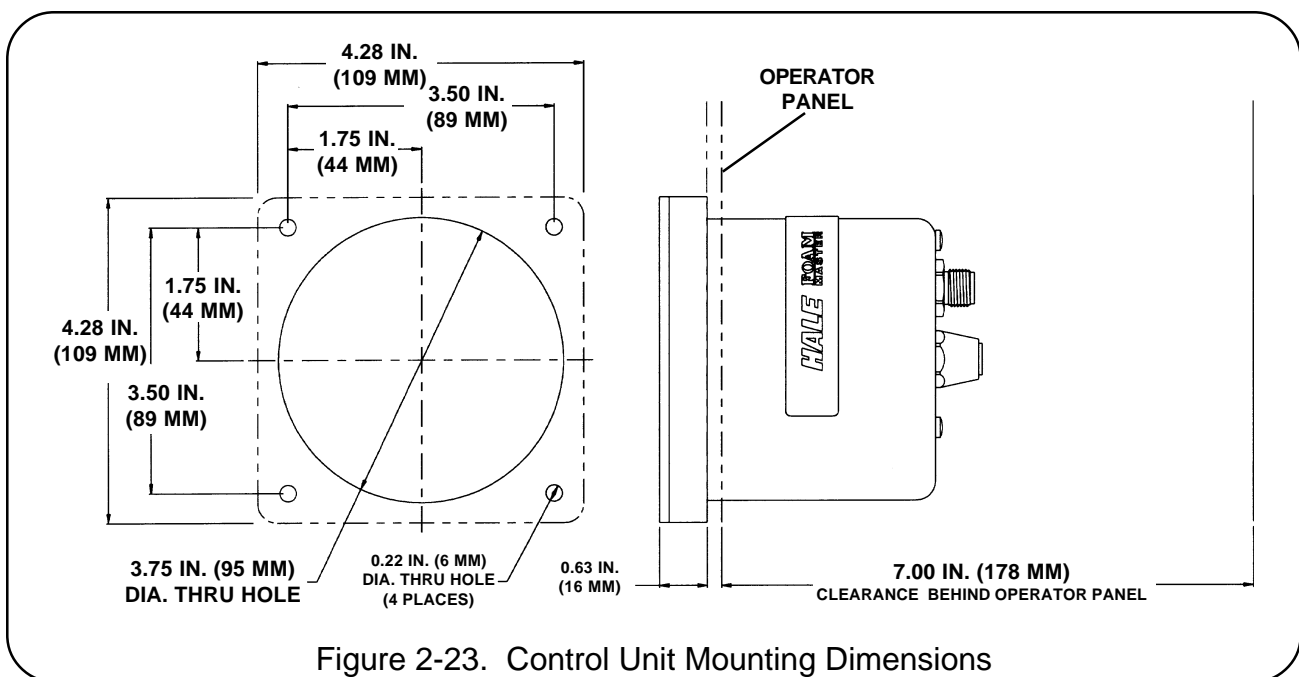

Figure 2-23. Control Unit Mounting Dimensions

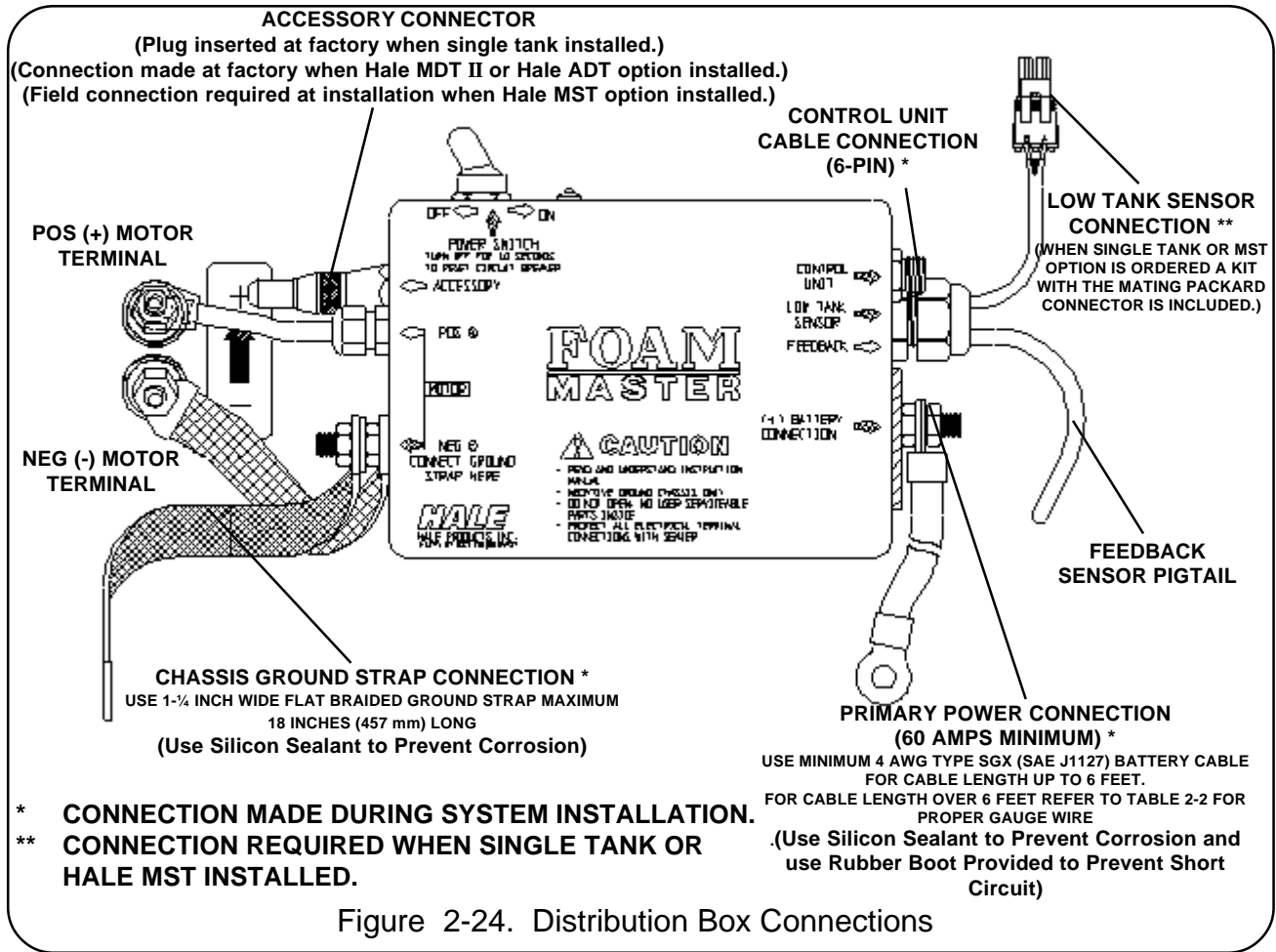

Figure 2-24. Distribution Box Connections

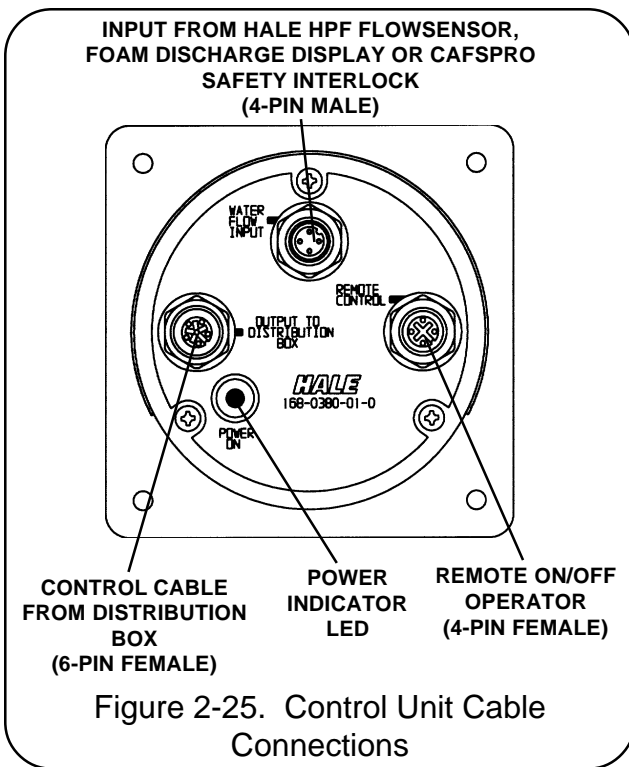

Figure 2-25. Control Unit Cable Connections

sensor in each foam tank as follows. Refer to figure 2-27 for low tank level sensor mounting options.

CAUTION: Foam tank low level sensors must be utilized to protect the Hale FoamMaster from dry running. Failure to use low level sensors with the Hale FoamMaster system will void warranty.

SIDE MOUNT LOW LEVEL SENSOR INSTALLATION

1. A side mount low tank level sensor is available to be used if the bottom of the foam tank is not accessible. The side mount low tank level sensor has 1/2 inch NPT threads. If tank design and construction allows, the side mount sensor can be threaded directly into the side of the tank at the proper height. Also the sensor can be mounted on the foam tank using a 1/2 x 1

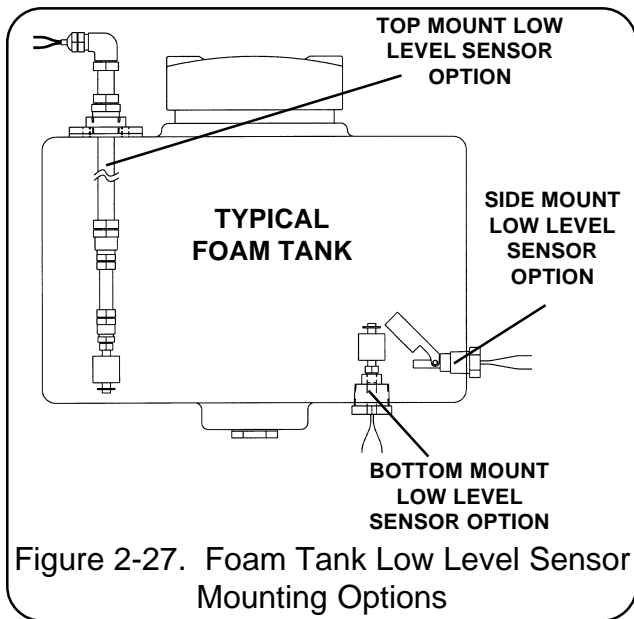
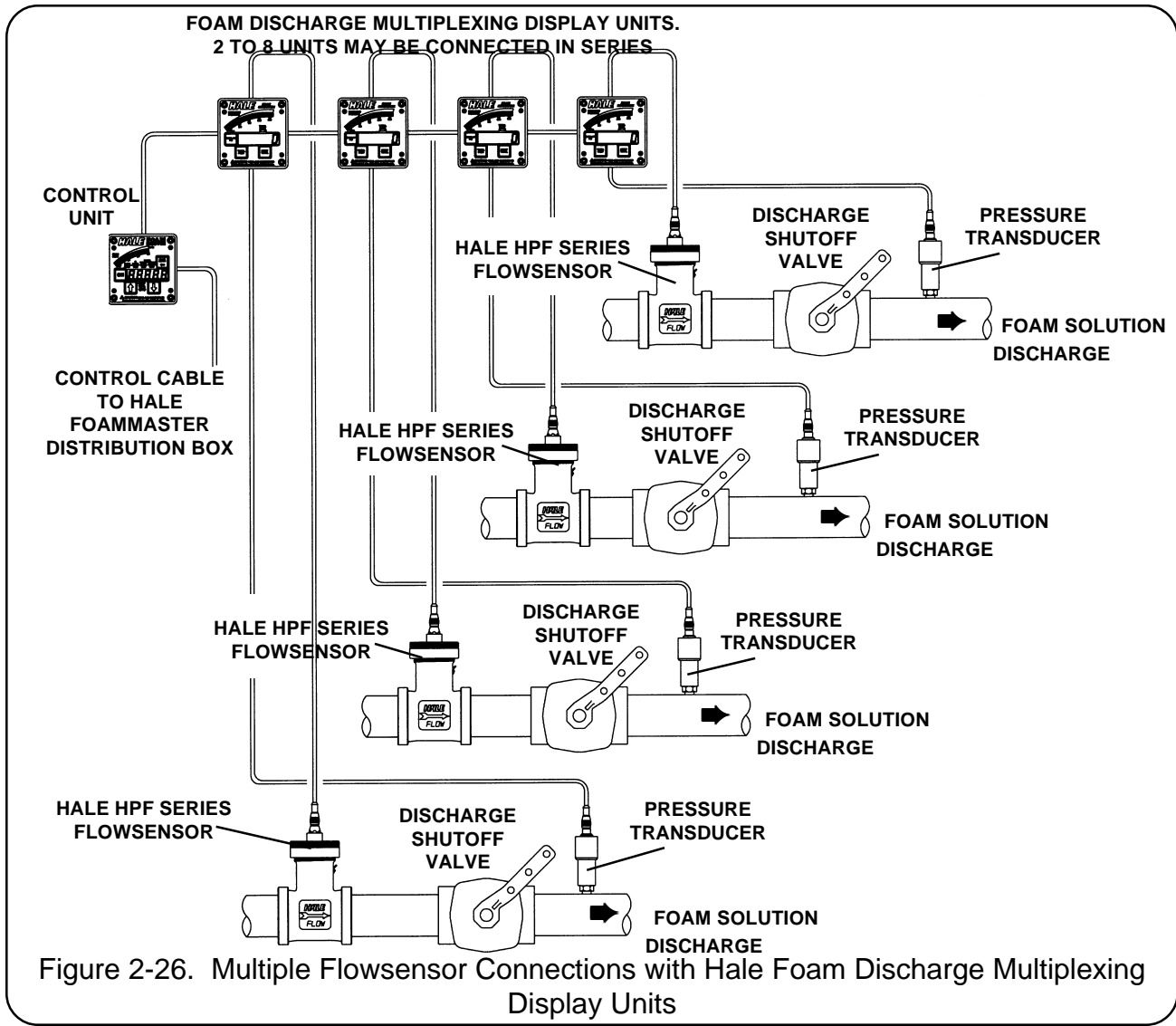

inch NPT bushing and a bulkhead fitting with 1 inch FNPT threads (see figure 2-28). The center of the switch must be located at least 1-½ to 2 inches (38 to 51 mm) from the bottom of the foam tank with the float positioned on top of the switch to move up and down.

NOTE: When the side mount low tank level sensor senses a low concentrate condition the system will operate for one minute unless the foam concentrate level is restored. If the foam concentrate level is not restored the Hale FoamMaster system will shut down. When locating the side mount low tank level sensor on the foam tank sufficient

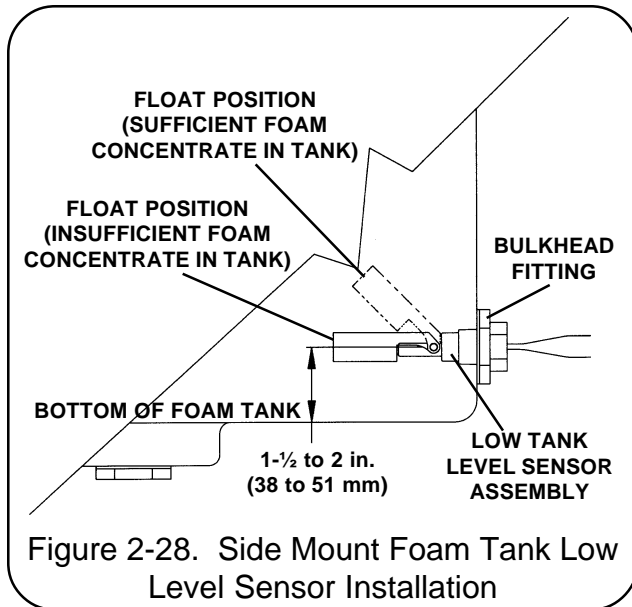

foam concentrate should be present for one minute of operation at rated flow.

2. Coat the threads of the low tank sensor with suitable sealant and insert into tank fitting. Tighten sensor making sure the float is on the top of the sensor.
3. After installation, check operation of the side mount low tank level sensor with a powered test light. With no foam in the tank, the light should be on. If light does not illuminate, rotate the side mount low tank level sensor until the test light is on.

BOTTOM MOUNT LOW LEVEL SENSOR INSTALLATION

1. The bottom mount foam tank low level sensor must be mounted into the bottom of the foam tank. The sensor, as supplied, is threaded into a bushing that has 1 inch NPT threads. The sensor is designed to be installed from the outside of the foam tank through a bulkhead fitting or boss with 1 inch FNPT threads. Mount the sensor in the bottom of the foam tank in an upright position. Use suitable sealant to prevent concentrate leakage.

NOTE: There must be sufficient space under the foam tank for the low tank level sensor wires to be routed to the

foam pump/motor assembly. Be sure not to remove the float from the shaft on the low tank level sensor assembly. If the float is installed in the reverse position, "lo A" or "lo b" will appear on the control unit and the system will automatically shut down even if there is foam in the tank.

2. Check low tank level sensor operation with a powered test light. With no foam in the tank, the light should be on. If this is not the case, remove the clip from the end of the sensor. Remove float and reinstall 180° out of position. Reinstall clip.

TOP MOUNT LOW LEVEL SENSOR INSTALLATION

A top mount low level sensor assembly is available for installations where the sides or bottom of the foam tank are not accessible or sensor service is required without draining the foam tank. The sensor assembly is flange mounted in an access hole at the top of the foam tank. The two section telescoping assembly permits adjustment of low tank level sensor position for various foam tank depths from 31-1/2 to 60 inches (800 to 1524 mm). Flange cutout dimensions are shown in figure 2-39. The flange gasket can also be used as a template to mark hole location.

- a. Using dimensions in figure 2-29, layout and drill holes in the top of the foam tank. The center of the sensor should be located at least 1-1/2 to 2 inches (38 to 51 mm) from the sides of the foam tank.

NOTE: The minimum depth of foam tank for installation of the top mount sensor without cutting the tube sections is 31-1/2 inches (800 mm). If the tank depth is less than 31-1/2 inches (800 mm) cut the tubing as described in step c.

- b. Determine the approximate length of the top mount low tank sensor extension by measuring from the top of the foam tank at the flange opening to the

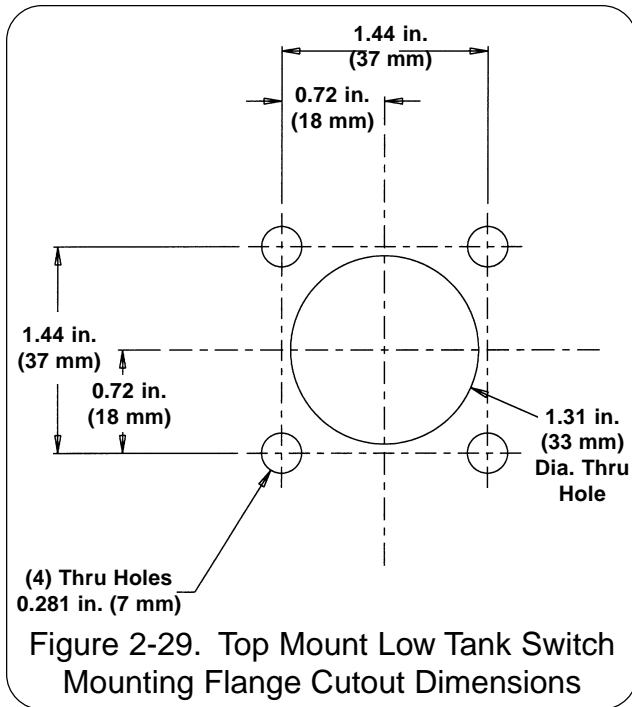

bottom of the tank. When properly installed the center of the sensor float should be 1-½ to 2 inches (38 to 51 mm) above the bottom of the foam tank.

c. Slide the flange to the top of the 5/8 inch diameter tube and adjust the telescoping section until the desired length is achieved as measured from the bottom of the flange to the bottom of the sensor. Tighten the compression fittings on the union to lock length.

NOTE: If telescoping section will not get short enough it can be disassembled and cut. Take care to deburr the ends of the tubes after they are cut. Cut an equal amount from each section of tubing.

IMPORTANT: Use the following procedure only if the tube sections are too long otherwise proceed to step d.

Refer to figure 2-30, disassemble and cut the tube sections as follows:

1) Loosen and remove the 3/8 FNPT x 5/8 tube fitting and strain relief from the top of the sensor assembly. Carefully

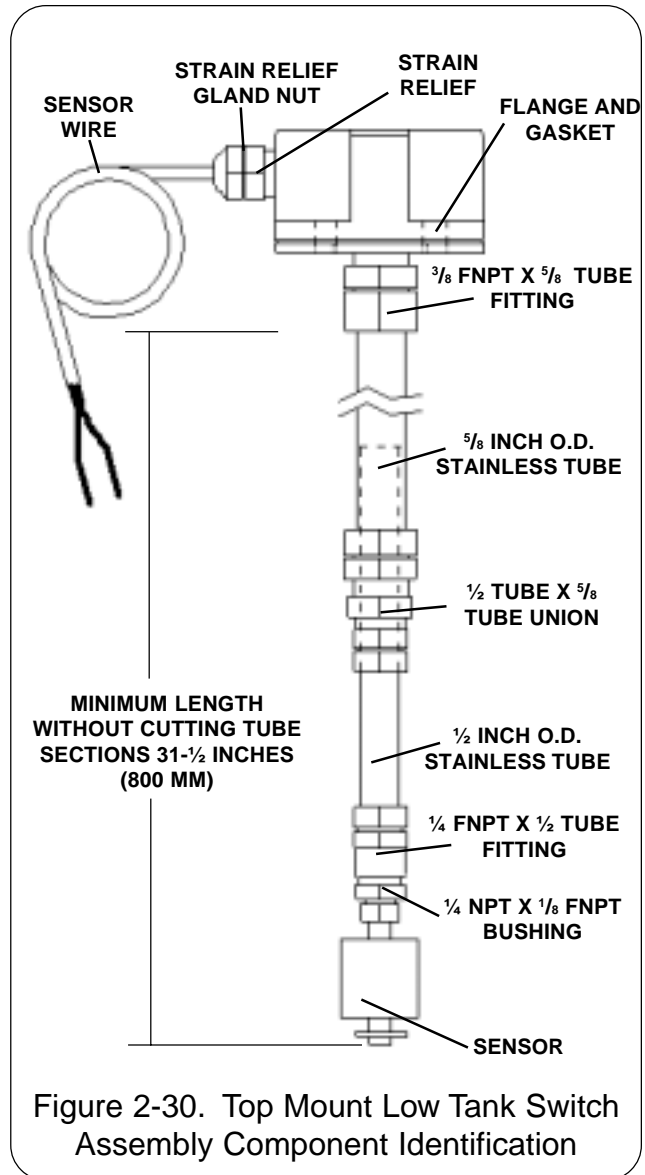

slide the sensor wire out of the strain relief gland.

2) Loosen and remove the 1/4 FNPT x 1/2 tube fitting and sensor from the bottom of the sensor assembly. DO NOT remove the 1/2 inch tube from the 5/8 inch tube.

3) Using a tubing cutter, remove the required length of tube from the end of each tube. Deburr the cuts when complete.

4) Install a new 1/2 compression ferrule on the end of the tube. Carefully thread the sensor wire through the tube assembly and attach the 1/4 FNPT x 1/2

tube fitting with sensor attached to the end of the tube. Tighten the ½ tube compression nut.

5) Install a new 5/8 compression ferrule on the end of the tube. Carefully thread the sensor wire through the 3/8 FNPT x 5/8 tube fitting and strain relief gland. Attach the 3/8 FNPT x 5/8 tube fitting and strain relief to the end of the tube. Tighten the 5/8 tube compression nut.

6) Slide the flange to the top of the 5/8 inch diameter tube and adjust the telescoping section until the desired length is achieved as measured from the bottom of the flange to the bottom of the sensor. Tighten the compression fittings on the union to lock length.

CAUTION: Use mounting hardware that is compatible with all foam concentrates to be used in the system. Use washers, lockwashers and capscrews made of brass or 300 series stainless steel.

d. Insert sensor assembly through the 1.31 inch (33 mm) hole and align the screw holes on the flange and gasket with the holes on the tank. Secure the assembly in place using four ¼-20 UNC x 1 inch long cap screws, ¼ inch washers and ¼ inch lockwashers.

e. Make final adjustment to the sensor position by pulling the tubing sections up through the flange until sensor is 1-½ to 2 inches (38 to 51 mm) from the bottom of the tank. Tighten the 5/8 tube compression nut on the flange.

f. Close strain relief to the 90° position making sure it snaps shut. Tighten strain relief gland nut to seal out water and contamination.

LOW LEVEL SENSOR WIRING

CAUTION: When extending the low tank sensor wires make sure the splices are

properly sealed using an adhesive filled heat shrink tubing.

SINGLE FOAM TANK SYSTEM

When a single foam tank system is installed use minimum 16 AWG Type SXL or GXL (SAE J1128) wire to extend the low tank sensor wire to allow connection to the 2-wire Packard WeatherPack connector on the distribution box (see figure 2-24). Low tank level sensors are not polarity sensitive therefore terminal connections are not specific.

If necessary, when making splices to extend the low tank sensor wires make sure the splices are sealed using an adhesive filled heat shrink tubing. Where two wires exit the heat shrink tubing pinch the tubing while heating the tubing to make sure the adhesive seals around both wires.

A connector kit (Hale P/N 546-1780-00-0) is included that contains a Packard Weatherpack 2-contact shroud half, two (2) 14-16 gage male terminals and two (2) 14-16 gage cable seals. Assemble these components to the end of the low tank sensor wires. Snap the two halves of the Packard WeatherPack connector together making sure they are sealed.

DUAL FOAM TANK SYSTEM

When the Hale FoamMaster system is installed using a Hale ADT or Hale MDT II connect the low tank level sensors using the following procedure (refer to figure 2-31):

CAUTION: Before running wires from the low tank switches to the A-B switch box make sure the wire from Tank A is identified and properly labeled.

1. Using minimum 16 AWG Type SXL or GXL (SAE J1128) wire, extend the pigtailed on the low tank level sensors to the A-B switch box. When making splices to extend the low tank sensor wires make sure the splices are sealed using an adhesive filled heat shrink tubing. Where

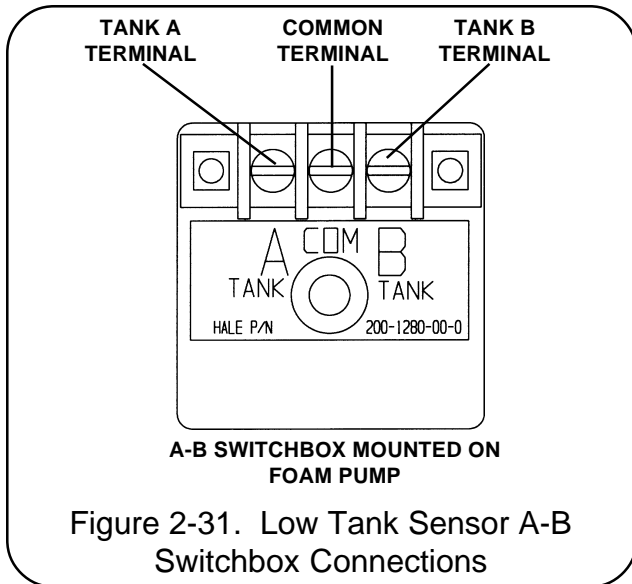

two wires exit the heat shrink tubing pinch the tubing while heating the tubing to make sure the adhesive seals around both wires.

CAUTION: Use the silicone sealer provided with the Hale FoamMaster system to insulate the terminal strip connection screws and prevent corrosion.

2. Tie one wire from each low level switch together as a common lead. Connect this common lead to the center screw on the terminal block on the A-B switch box.
3. Connect the lead from Tank A to the terminal labeled A TANK on the switch box and connect the wire from Tank B to the terminal labeled B TANK.
4. Seal the terminal strip connections using the silicone sealer provided.

GROUND AND PRIMARY POWER CONNECTIONS

CAUTION: Connect the primary positive lead from the terminal block to the master switch terminal or relay terminal using minimum 4 AWG type SGX (SAE J1127) chemical resistant battery cable and protect with wire loom.

CAUTION: Prevent corrosion of power and ground connections by sealing these connections with silicone sealant provided.

GROUND CONNECTION

Be sure the Hale FoamMaster system is grounded to the chassis. Use a short length of wide flat ground strap at least 1-¼ inches (32 mm) wide and less than 18 inches (457 mm) long to reduce the potential of RFI emitted by this connection. A stud labeled **NEG (—)** is located on the distribution box to attach the chassis ground strap to the Hale FoamMaster system. (See figure 2-24) When making the ground strap connections make sure lugs are attached to the strap ends for trouble free connections.

When the length of the ground strap exceeds 18 inches (457 mm) use a wider strap or a double thickness strap.

CAUTION: DO NOT connect the main power lead to small leads that are supplying some other device such as a light bar or siren. The Hale FoamMaster Model 3.3 and Model 5.0 require 60 AMP minimum current. The Hale FoamMaster Model 3.0 requires 40 AMP minimum current.

PRIMARY POWER SUPPLY CONNECTION

Make sure adequate switched electrical power from the battery + terminal to the battery connection stud on the distribution box (see figure 2-24) is provided. Use 4 AWG minimum type SGX (SAE J1127) battery cable directly to the battery, battery switch or solenoids for cable runs up to 6 feet (1.8 meters) long. Longer wire runs may require larger battery cable for proper operation. **DO NOT** connect power to the same connection as the pump primer. The following table provides recommended cable size for various lengths of cable run.

Table 2-1

RECOMMENDED PRIMARY POWER CABLE SIZES		
Model 3.0	Models 3.3 & 5.0	Maximum Length
6 AWG	4 AWG	6 Ft (1.8 M) or Less
4 AWG	0 AWG	6 Ft (1.8 M) to 15 Ft (4.6 M)
0 AWG	00 AWG	15 Ft (4.6 M) or Longer

RF/EMI

Electrically shielded cables for control unit, flowsensor, foam discharge multiplexing display units and pressure transducers are provided with the Hale FoamMaster system. The cables are 100% electrically shielded to eliminate the potential problem of EMI/RFI. Proper installation of system components and cables along with proper grounding will limit radio interference caused by the Hale FoamMaster system. Additionally, make sure radio cables and hardware are not located in the immediate area where Hale FoamMaster equipment is mounted.

Make sure the flowsensor tee is grounded. If metal piping is used sufficient grounding may be present. However, Victaulic joints, plastic pipe and rubber mounted pumps interfere with proper grounding and an additional ground strap may be required. If necessary, connect a flat braided ground

strap at least ¼ inch (6 mm) wide from the flowsensor tee to the apparatus frame to ensure proper grounding. The #6-32 UNC screw that holds the spade terminal to the flowsensor tee can be used to attach the ground strap to the tee (refer to figure 2-11).

Making round coils of extra control and flowsensor cables in the pump compartment can act as an antenna. While the control and flowsensor cables cannot be shortened, various lengths of cable are available to minimize the "extra" cable in the truck. When routing control and flowsensor cables take care to avoid routing them next to antenna wires, radio power lines and radio components. When there is extra cable, double the cable back on itself and secure with plastic wire ties in a flat bundle instead of making a round coil. (See Figure 2-32)

REMOTE ACTIVATION SWITCH

Choose a location in the apparatus personnel compartment for mounting the remote activation switch. Make sure the switch is accessible to the operator without interfering with other controls on the apparatus.

To install the remote activation switch use the following procedures:

1. Determine location on panel where switch is to be mounted. Refer to figure 2-33 and layout panel cutout and mounting holes as shown.
2. Make panel cutout and drill the four 0.203 inch (5 mm) diameter thru holes.
3. Insert switch assembly through panel cutout and secure to panel using the #10-24 UNC x ½ inch long screws and #10-24 UNC nuts provided.

NOTE: When making cable connection make sure the cable is routed by the shortest most direct route. A maximum of 40 feet (12 meters) of remote cable may be used.

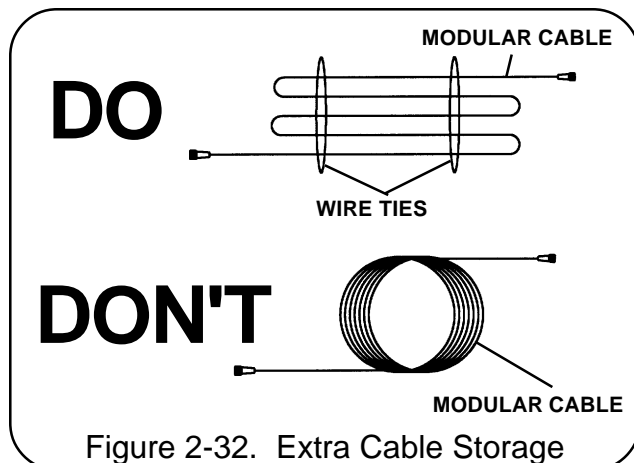
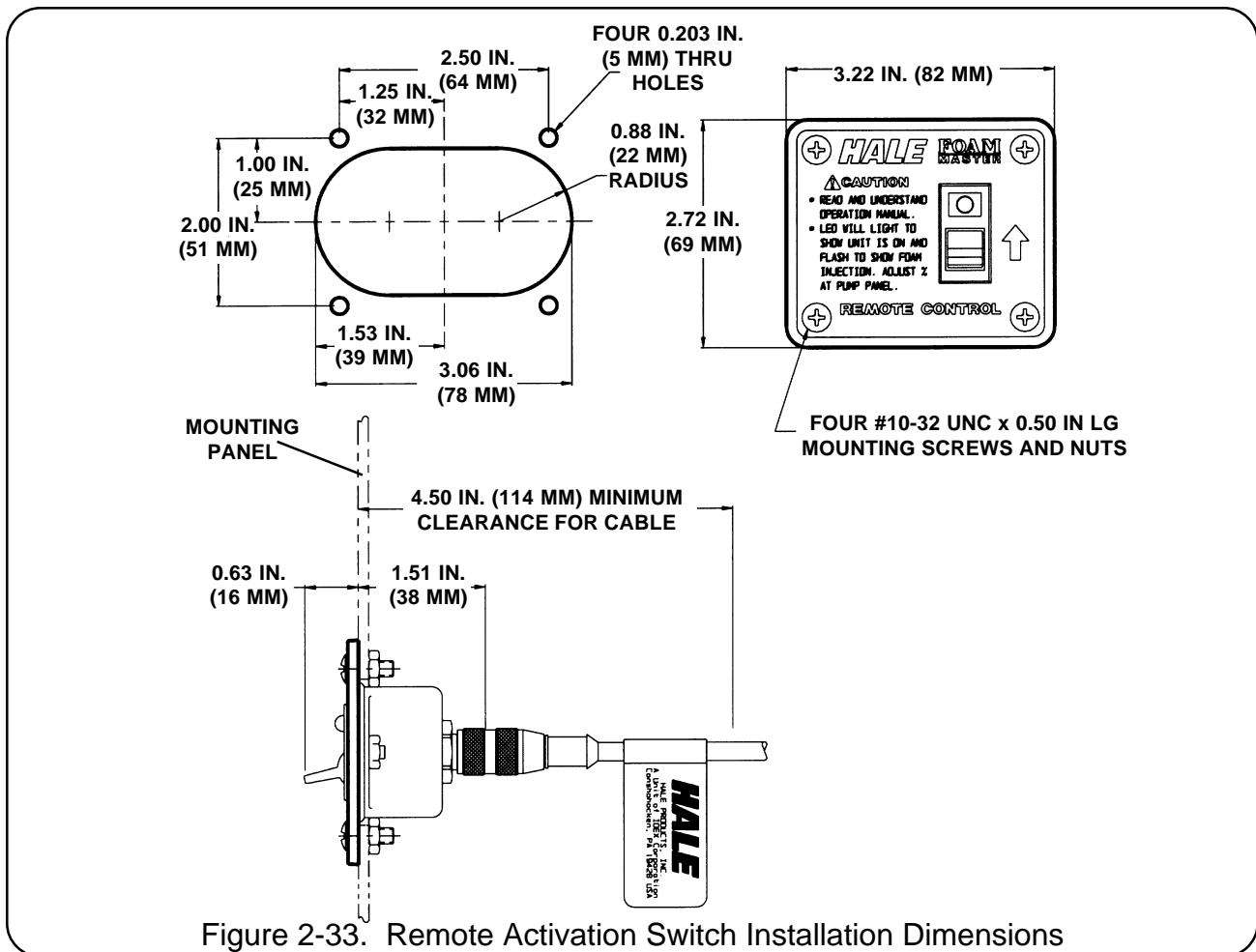
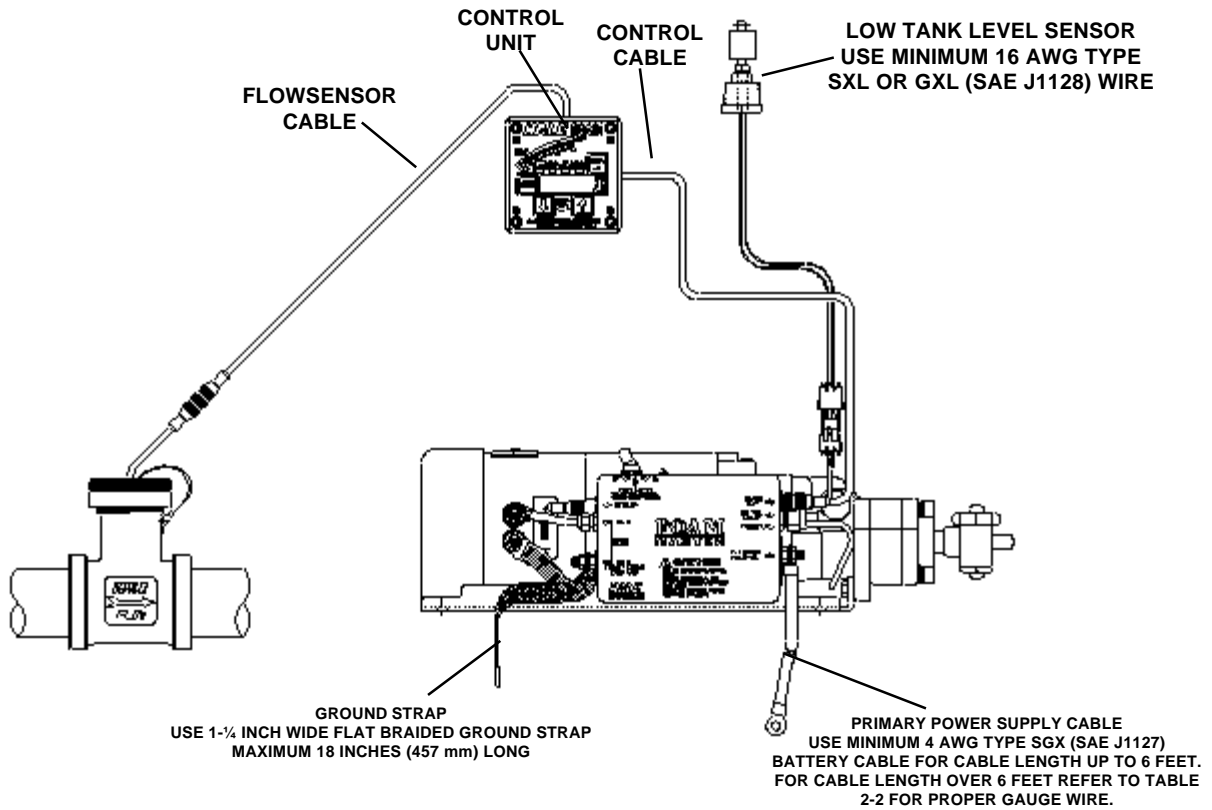

Figure 2-32. Extra Cable Storage

4. Connect the remote activation switch cable from the connector on the control unit (see figure 2-25) to the connector on the back of the remote activation switch.



HALE FOAMMASTER SYSTEM ELECTRICAL DIAGRAMS



HALE FOAMMASTER SYSTEM (NO TANK OPTION)

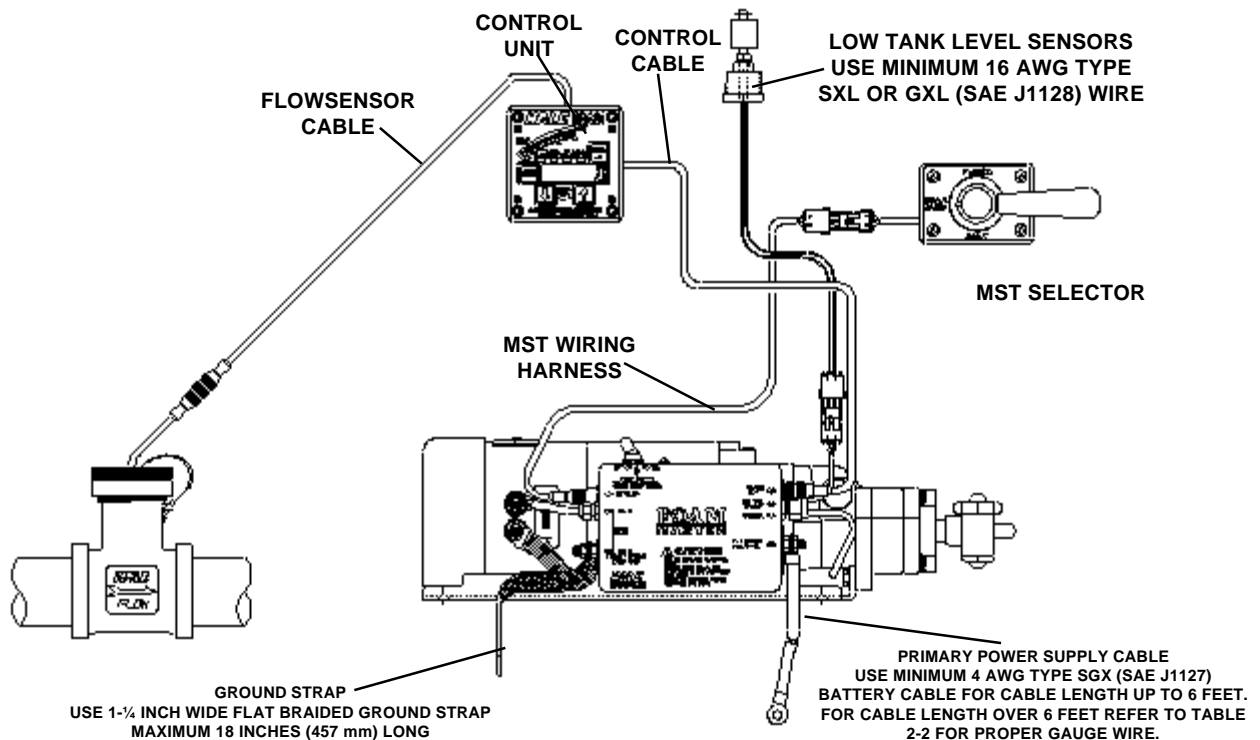

HALE FOAMMASTER SYSTEM WITH MST

HALE FOAMMASTER SYSTEM ELECTRICAL DIAGRAMS (Continued)

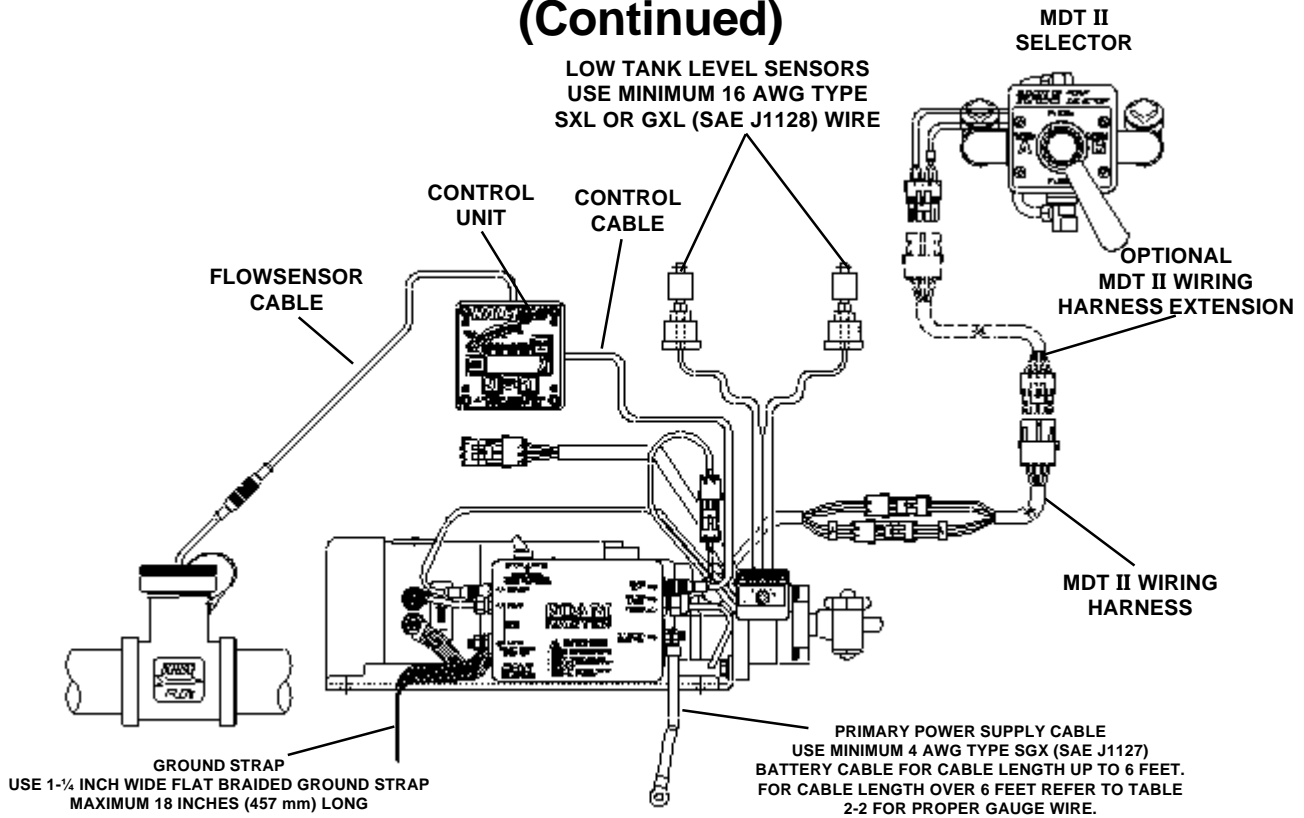

HALE FOAMMASTER SYSTEM WITH MDT II

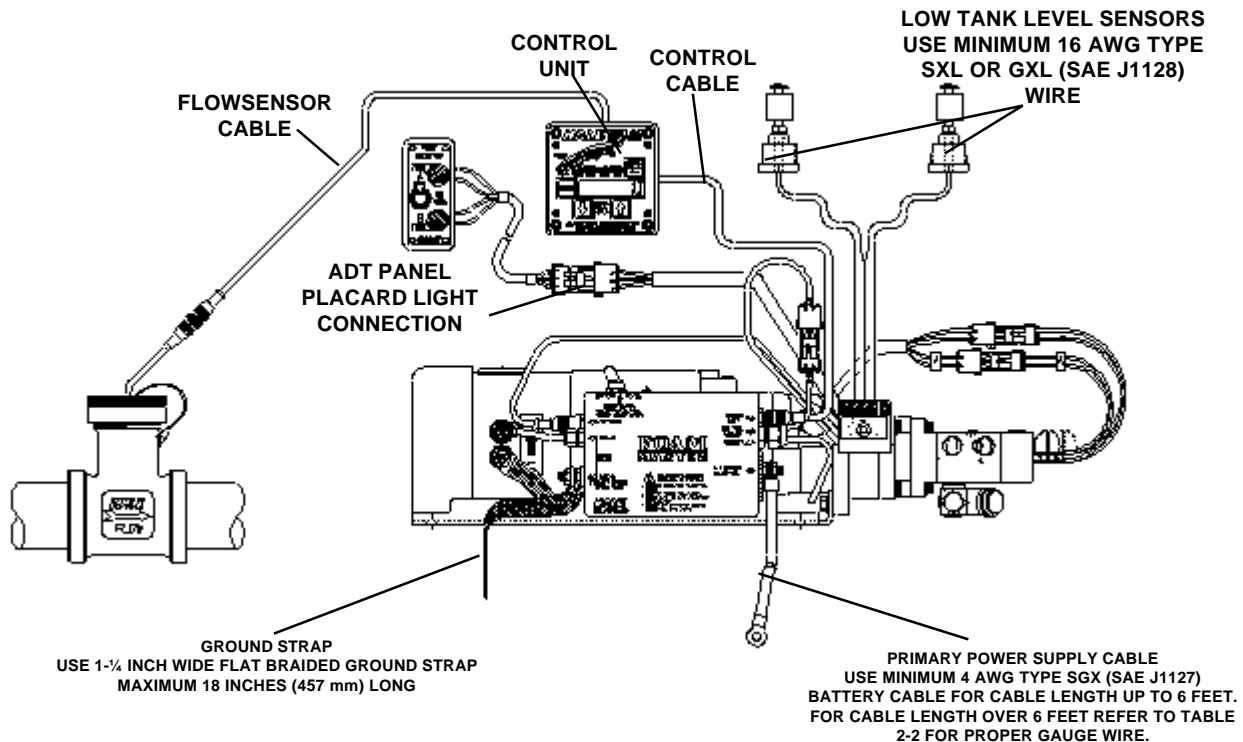

HALE FOAMMASTER SYSTEM WITH ADT

START-UP CHECKLIST

Before energizing the apparatus and Hale FoamMaster system for the first time make sure the following items are checked:

Electrical

- Tank level sensor(s) wires connected to distribution box and sealed from moisture.
- Tank level sensor(s) function properly.
- Control cable connection at distribution box correct and tight.
- Flowsensor cable properly connected to control unit or foam discharge multiplexing display unit.
- All cables and wires are secured and protected from damage during operation.
- Control and flowsensor cables properly folded and secured; radio antennas, power lines and equipment away from cables.
- Foam Pump and motor assembly properly grounded using flat ground strap.
- Correct voltage provided. Direct current, negative ground.
- Adequate current, 60 AMPS minimum, available. Main power direct to battery, battery switch or solenoid without primer or other accessories tied in.
- Primary electrical and ground connections tight and protected from corrosion with silicone sealant.
- Splices in wires sealed from moisture using adhesive filled heat shrink tubing.
- Hale FoamMaster system ON/OFF switch on the distribution box is in the ON position.
- If installed, ADT, MST or MDT II electrical connections correct.
- If installed, Remote ON/OFF switch cable connection correct.

Liquid

- Flowsensor(s) mounted with flow arrow in the correct direction for water flow.
- Check valves are properly mounted in water and foam concentrate lines.
- Strainer mounted for proper concentrate flow direction in foam tank to pump hose.
- Foam tank to foam pump valve is in place and open.
- Check valve/injector fitting lines are proper size and connections are tight.
- BYPASS valve is properly mounted and oriented for direction of concentrate flow.
- Foam concentrate gravity feeds to foam pump from foam concentrate tank.
- All hoses free of kinks and sharp bends.
- No sharp bends that can trap air exist in system.
- MST positioned to **FOAM TANK** or MDT II positioned to **TANK A**.
- Flush water connections correct and tight.
- Discharge piping hydro tested in accordance with NFPA/UL requirements.
- Bypass valve handle is in the INJECT position.

Foam Pump

- Foam pump and motor assembly mounted in horizontal position with base plate down.
- Foam pump and motor assembly properly secured using proper mounting hardware.
- Foam pump suction and discharge hoses connected to proper ports.
- Foam pump suction and discharge hose fittings tight.

Optional ADT

- Panel placard mounted on operator panel.
- Air hoses connected and connections tight.
- Selector switch is in the **TANK A** position.
- Bypass handle is in the INJECT position.

SYSTEM INSTALLER START-UP

When energizing the Hale FoamMaster system at the system installer facility for the first time the following procedures shall be used.

INITIAL SYSTEM POWER CHECK

Observe the display on the control unit while energizing the apparatus electrical system and turn the foam pump distribution box power switch to **ON**. Check the control unit readout — **FLOW, TOTAL FLOW, % FOAM, TOTAL FOAM, ON** and all bargraph LEDs will light along with "88888" for several seconds. "HALE" will then appear for several seconds while the system checks itself followed by the default display. If the Hale FoamMaster system is installed with a single flowsensor the default display is zero on the digital readout (if no water is flowing) and FLOW LED (See figure 2-33). When the Hale FoamMaster is installed using multiple flowsensors and foam discharge multiplexing display units the default display is **% FOAM**. If default display does not appear refer to TROUBLESHOOTING for possible causes and solutions.

INITIAL SYSTEM OPERATION CHECK

After initial system power-up, low tank level sensor operation, foam pump operation and flowsensor calibration must be checked. Use the following procedures to complete these system checks.

CAUTION: Water is used at the system installer facility to verify low tank level sensor operation and foam pump operation as the end user specified foam concentrates may not be readily available. DO NOT pump water with the Hale FoamMaster foam pump for more than one minute per foam tank. DO NOT attempt to calibrate foam pump feedback sensor with other than end user specified foam concentrate. Make sure the bypass valve is in the BYPASS position when pumping water with the foam pump.

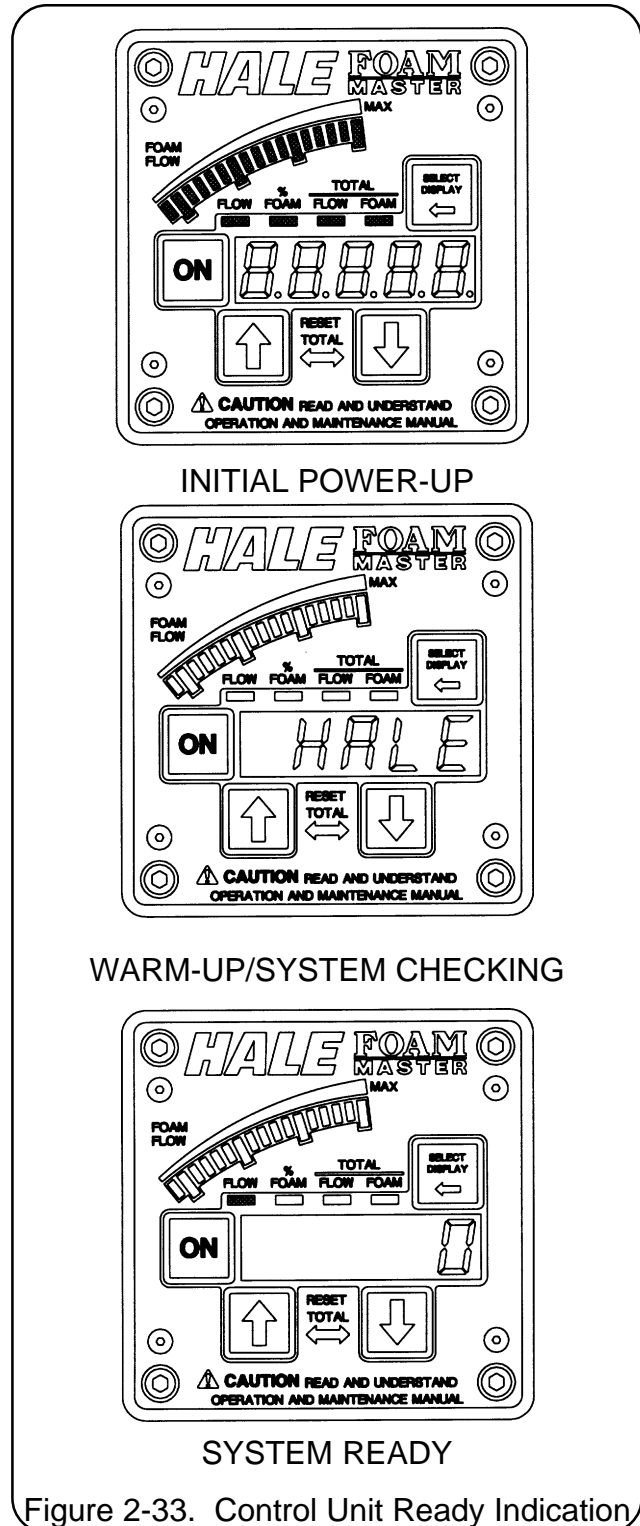

Figure 2-33. Control Unit Ready Indication

1. Upon initial power-up with the foam tanks empty the display on the control unit will alternate between "0" and "Lo A" indicating the foam tank is empty. Fill foam concentrate tank A with water. The "Lo A" indication should disappear from the control unit display indicating the low tank level sensor in Tank A is operating properly.

2. If the system is equipped with ADT or MDT II move the selector to TANK B position and observe the control unit display. The display should alternate between "0" and "Lo b" indicating the foam tank is empty. Fill foam concentrate tank B with water. The "Lo b" indication should disappear from the control unit display indicating the low tank level sensor in Tank B is operating properly.

3. If the system is equipped with ADT, MDT II or MST place the selector in the **FLUSH** position. "FLUSH" should alternate with "0" on the control unit display. Once proper operation is verified place the selector to **TANK A** position (or **FOAM TANK** position on MST).

NOTE: The bypass valve on the ADT is a pull to operate device. There are two detents that the valve must pass through to be fully open. Make sure the bypass valve is fully opened before attempting to operate foam pump.

4. Place the BYPASS valve to the **BYPASS** position to check foam pump operation. Place a calibrated one gallon container at the discharge of the bypass hose.

5. Place the system in simulated flow mode by selecting the **FLOW** display and depressing **RESET** (both up ↑ and down ↓ buttons simultaneously). Set simulated flow value to 100 GPM by pressing up ↑

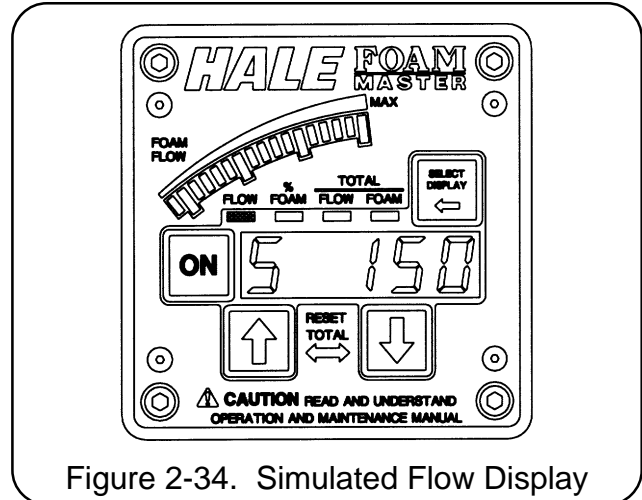

Figure 2-34. Simulated Flow Display

or down ↓ button. Display will show "S" at the left most position to indicate the simulated flow (See figure 2-34).

6. Depress the **SELECT DISPLAY** button until the LED under **% FOAM** lights. Set foam concentrate injection rate to "1.0" by pressing up ↑ or down ↓ button.

7. Depress the **SELECT DISPLAY** button until the LED under **TOTAL FOAM** lights. Depress **ON** button to energize Hale FoamMaster system. Observe the discharge of the bypass hose to make sure the foam pump is operating. After one minute depress the **ON** button to stop the foam pump. There should be approximately one gallon of water in the container and the **TOTAL FOAM** display on the control unit should read approximately "1.0".

8. If the system is equipped with ADT or MDT II move the selector to **TANK B** position and repeat steps 6 through 8 for tank B.

9. After foam pump operation has been checked with both foam tanks exit simulated flow mode by selecting the **FLOW** display and depressing **RESET** (both up ↑ and down ↓ buttons simultaneously).

10. Drain water from foam tanks and concentrate lines and return the bypass valve to the **INJECT** position.

11. Verify operation of and calibrate flowsensor(s) as required using flowsensor calibration procedures in the user calibration section.

This completes the Hale FoamMaster system operation checks that can be accomplished at the system installer facility. Foam pump feedback calibration along with setting of user specified default simulated flow and concentrate injection rates should be accomplished upon delivery to the end user using actual end user specified foam concentrates and default values.

HALE

FOAM MASTER

ROTARY GEAR PUMP ELECTRONIC FOAM PROPORTIONING SYSTEM

DESCRIPTION, INSTALLATION AND OPERATION
MANUAL

SECTION III SET-UP AND CALIBRATION

NOTICE: This manual section is used by the installer and end user for setting up and calibrating the Hale FoamMaster system. This manual section also provides procedures for the end user to change default values and verify calibration if different foam concentrates are used. This manual section can be used as a stand alone section or in conjunction with other sections of the complete manual.

HALE PRODUCTS, INC. • A Unit of IDEX Corporation • 700 Spring Mill Avenue • Conshohocken, PA 19428 • TEL: 610-825-6300 • FAX: 610-825-6440



Hale Products cannot assume responsibility for product failure resulting from improper maintenance or operation. Hale Products is responsible only to the limits stated in the product warranty. Product specifications contained in this material are subject to change without notice.



SAFETY

Hale FoamMaster systems are designed to provide reliable and safe foam concentrate injection. Before installing or operating a Hale FoamMaster system read all safety precautions and follow carefully to ensure proper installation and personnel safety.

WARNINGS

1. Do not permanently remove or alter any guard or insulating devices or attempt to operate the system when these guards are temporarily removed.
2. To prevent electrical shock always disconnect the primary power source before attempting to service any part of the Hale FoamMaster system.
3. All electrical systems have the potential to cause sparks during service. Take care to eliminate explosive or hazardous environments during service/repair.
4. To prevent system damage or electrical shock the main power supply wire will be the last connection made to the Hale FoamMaster distribution box.
5. Release all pressure then drain all concentrate and water from the system before servicing any of its component parts.
6. Rotating drive line components can cause injury. When working on components of the Hale FoamMaster system be careful of rotating components.
4. Hale FoamMaster systems are designed for use on negative ground direct current electrical systems only.
5. Do not mount radio transmitter or transmitter cables in direct or close contact with the Hale FoamMaster unit.
6. Before connecting the cordsets inspect the seal washer in the female connector. If the seal washer is missing or damaged, water can enter the connector causing corrosion of the pins and terminals resulting in possible system failure.
7. Always disconnect the power cable, ground straps, electrical wires and control cables from the control unit or other Hale FoamMaster equipment before electric arc welding at any point on the apparatus. Failure to do so could result in a power surge through the unit that could cause irreparable damage.
8. **DO NOT** connect the main power lead to small leads that are supplying some other device such as a light bar or siren. The Hale FoamMaster Model 3.3 and Model 5.0 require 60 AMP minimum current. The Hale FoamMaster Model 3.0 requires 40 AMP minimum current. Use correct gauge wire as specified.

CAUTIONS

1. Foam tank low level sensors must be utilized to protect the Hale FoamMaster from dry running. Failure to use low level sensors with the Hale FoamMaster system will void warranty.
2. Do not operate system at pressures higher than the maximum rated pressure.
3. Use only pipe, hose, and fittings from the foam pump outlet to the injector fitting, which are rated at or above the maximum pressure rating at which the water pump system operates.
9. When operating the Hale FoamMaster in Simulated Flow mode an outlet for the foam concentrate must be provided to prevent excessive pressure buildup in discharge piping or hoses.
10. Unless engaged in Class B foam operations, the Hale FoamMaster ADT toggle switch or Hale FoamMaster MDT II selector handle must be in the **TANK A** position. If the toggle switch or selector handle is in the **FLUSH** position when the Hale FoamMaster foam pump is started the foam pump will only run for 20 seconds and shut down.

11. Make sure the foam tank and foam concentrate suction hoses are clean before making final connection to foam pump. If necessary flush tank and hoses prior to making connection.

NOTES

1. Check all hoses for weak or worn conditions after each use. Ensure that all connections and fittings are tight and secure.
2. Ensure that the electrical source of power for the unit is a negative ground DC system, of correct input voltage, with a reserve minimum current available to drive Hale FoamMaster system.
3. The in-line strainer/valve assembly is a low pressure device and WILL NOT withstand flushing water pressure. When installing the in-line strainer in systems equipped with Hale MDT II or Hale MST make sure the in-line strainer/valve assembly is in the hose on the inlet side of the valve. If the strainer will be subject to flushing water pressure, use Hale FS series strainers.
4. When determining the location of Hale FoamMaster components keep in mind piping runs, cable routing and other interferences that will hinder or interfere with proper system performance.
5. The Hale HPF flowsensor is assembled and tested at the factory. Removal of the flow sensor from the tee is not necessary or recommended for installation in the system.
6. Always position the check valve/injector fitting at a horizontal or higher angle to allow water to drain away from the fitting. This will avoid sediment deposits or the formation of an ice plug.
7. The cordsets provided with each Hale FoamMaster system are 100% electrically shielded assemblies. Never attempt to shorten or lengthen the molded cables. If necessary order longer or shorter cordsets from Hale Products to suit the particular installation.
8. The cordsets provided with each Hale FoamMaster system are indexed so they

only go in the correct receptacle and they can only go in one way. When making cordset connections DO NOT force mismatched connections as damage can result in improper system operation.

9. The system can only perform when the electrical connections are sound, so make sure each one is correct.
10. The cables shipped with each Hale FoamMaster system are 100% tested at the factory with that unit. Improper handling and forcing connections can damage these cables which could result in other system damage.
11. There are no user servicable parts inside Hale FoamMaster system electrical/electronic components. Opening of these components (distribution box, control unit, foam discharge multiplexing display unit) will void warranty.
12. Use mounting hardware that is compatible with all foam concentrates to be used in the system. Use washers, lockwashers and capscrews made of brass or 300 series stainless steel.
13. When making wire connections make sure they are properly insulated and sealed using an adhesive filled heat shrink tubing.
14. Before running wires from the low tank switches to the A-B switch box make sure the wire from Tank A is identified and properly labeled.
15. **ALWAYS** connect the primary positive power lead from the terminal block to the master switch terminal or the positive battery terminal using minimum 4 AWG type SGX (SAE J1127) chemical resistant battery cable and protect with wire loom.
16. Prevent corrosion of power and ground connections by sealing these connections with silicone sealant provided.
17. Prevent possible short circuit by using the rubber boot provided to insulate the primary power connection at the Hale FoamMaster distribution box.

INSTALLATION AND DELIVERY CHECKLIST

After the Hale FoamMaster system has been installed the following check list should be used to verify installation and ensure proper system set-up when apparatus is delivered to the end user. Use procedures in referenced manual sections.

INSTALLATION

DATE INITIALS

- | | | |
|-------|-------|-------------------------------------------------------------------------------------------------------------------------------------------|
| _____ | _____ | <input type="checkbox"/> System properly installed according to installation section of manual. (SECTION II; START-UP CHECKLIST) |
| _____ | _____ | <input type="checkbox"/> Tank level sensor function verified for Tank A and Tank B (as equipped). (SECTION II; SYSTEM INSTALLER START-UP) |
| _____ | _____ | <input type="checkbox"/> Foam pump operation checked for both Tank A and Tank B (as equipped). (SECTION II; SYSTEM INSTALLER START-UP) |
| _____ | _____ | <input type="checkbox"/> Flush indication on control unit display verified. (SECTION II; SYSTEM INSTALLER START-UP) |
| _____ | _____ | <input type="checkbox"/> Foam tank(s) and hoses drained of water. (SECTION II; SYSTEM INSTALLER START-UP) |
| _____ | _____ | <input type="checkbox"/> Flowsensor(s) function checked and flowsensor(s) calibrated as necessary. (SECTION III; USER CALIBRATION) |

DELIVERY

DATE INITIALS

- | | | |
|-------|-------|----------------------------------------------------------------------------------------------------------------------------------------------------------------------|
| _____ | _____ | <input type="checkbox"/> Foam tank(s) filled with user specified foam concentrate(s). (SECTION III; INITIAL END USER SET-UP) |
| _____ | _____ | <input type="checkbox"/> Foam pump priming checked for both foam concentrate tank(s). (SECTION III; INITIAL END USER SET-UP) |
| _____ | _____ | <input type="checkbox"/> Flowsensor calibration verified with pitot. (SECTION III; USER CALIBRATION) |
| _____ | _____ | <input type="checkbox"/> Default simulated flow value set to end user specification. (SECTION III; USER CALIBRATION) |
| _____ | _____ | <input type="checkbox"/> Default foam concentrate injection rate(s) set to end user specification for each foam tank (as equipped). (SECTION III; USER CALIBRATION) |
| _____ | _____ | <input type="checkbox"/> Foam concentrate feedback values verified and calibrated with end user specified foam concentrate(s). (SECTION III; USER CALIBRATION) |
| _____ | _____ | <input type="checkbox"/> Proper Hale FoamMaster system operation demonstrated to end user in accordance with manual procedures. (SECTION IV; OPERATING INSTRUCTIONS) |
| _____ | _____ | <input type="checkbox"/> End user trained in proper operation of Hale FoamMaster system in accordance with manual procedures. (SECTION IV; OPERATING INSTRUCTIONS) |
| _____ | _____ | <input type="checkbox"/> Warranty registration card filled out by end user and mailed to Hale Products Inc. |
| _____ | _____ | <input type="checkbox"/> Two copies of Description, Installation and Operation manual provided to end user. |

INITIAL END USER SET-UP

When the apparatus is delivered to the end user facility the foam tank(s) must be filled with the specified foam concentrate(s). Make sure the proper foam concentrate is put into the correct tank. The system must then be adjusted to operate with the end user foam concentrate(s) for best accuracy.

SYSTEM POWER CHECK

Observe the display on the control unit while energizing the apparatus electrical system and turn the foam pump distribution box power switch to **ON**. Check the control unit readout — **FLOW, TOTAL FLOW, % FOAM, TOTAL FOAM, ON** and all bargraph LEDs will light along with "88888" for several seconds. "HALE" will then appear for several seconds while the system checks itself followed by the default display (See figure 3-1). If default display does not appear, refer to TROUBLESHOOTING for possible causes and solutions.

PRIMING FOAM PUMP

After the foam tank(s) are filled and the system is powered up foam concentrate flow must be checked to verify the foam pump is primed.

CAUTION: When operating the Hale FoamMaster in Simulated Flow mode an outlet for the foam concentrate must be provided to prevent excessive pressure buildup in discharge piping or hoses.

1. Make sure the bypass valve is in the **BYPASS** position. Route the bypass hose into a suitable container to collect the discharged foam concentrate.
2. If dual foam tank system is used select **TANK A**. Make sure there is foam concentrate in both foam tanks.
3. Place the system in simulated flow mode by selecting the **FLOW** display and

depressing **RESET** (both up ↑ and down ↓ buttons simultaneously). Increase simulated flow value by

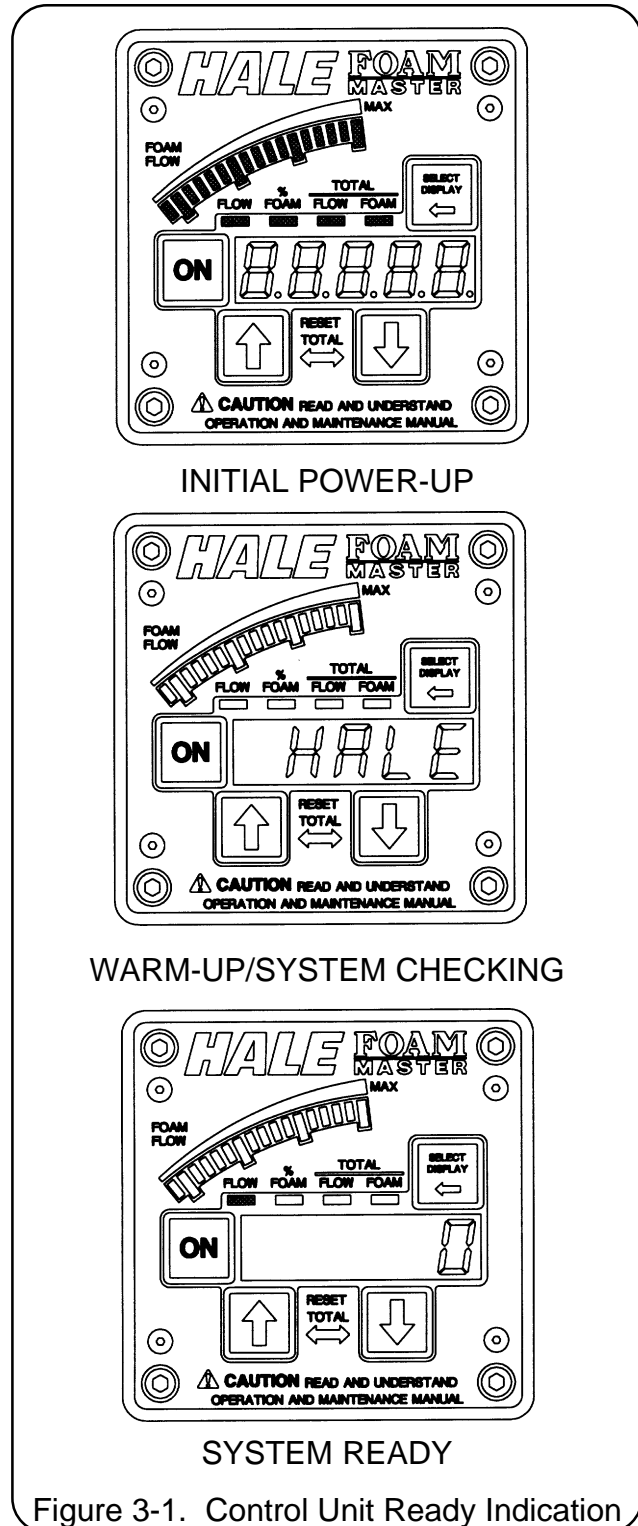

Figure 3-1. Control Unit Ready Indication

pressing **↑** button to permit easier priming (above factory default value of 150 GPM). Display will show "S" at the left most position to indicate the simulated flow (See figure 3-2).

- Engage the Hale FoamMaster system by pressing the red **ON** button. The **ON** button will illuminate to indicate the system is on and the bargraph indicates whether foam concentrate is being pumped. If no concentrate is flowing the pump will increase to maximum speed in an attempt to prime itself. The pump will run at full speed until a feedback signal is indicated or for 30 seconds. If no feedback signal is present after 30 seconds the system will shut down and the display will show "noPr" (no prime). Repeat this step one more time to attempt to prime the pump.

If the foam pump does not prime after the second try do the following:

- Make sure all foam concentrate valves are open.
- Make sure there are no restrictions in the hose from the foam concentrate tank to the inlet of the foam pump.
- Make sure there are no air traps in the hose from the foam concentrate tank to the inlet of the foam pump.
- Make sure there are no leaks in the plumbing where air can enter the pump.

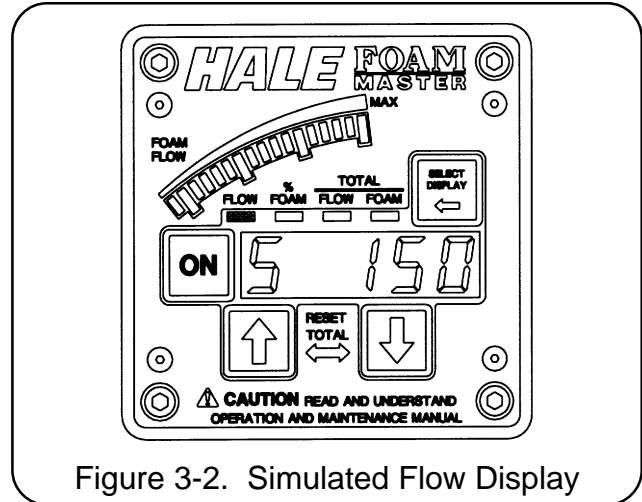

- If the system has been installed properly, foam concentrate should flow readily to the pump. Observe the clear foam suction line to verify if foam is flowing.
- If a dual tank system is installed switch to **TANK B** and repeat priming procedure for that tank.
- Once foam flow is established from both tanks, turn the system off and turn the bypass valve back to the **INJECT** position.

Proceed with user calibration procedures as system calibration must now be verified with the end user foam concentrate.

USER CALIBRATION

The complete Hale FoamMaster System; foam pump and motor assembly, control unit and flowsensor, is tested and calibrated at the factory before shipping to the installer. Each component of the matched system is assigned the same serial number to ensure they remain together. If the Hale FoamMaster system is properly installed, further calibration WILL NOT be necessary until delivery to customer. The system is designed to permit easy checking of component calibration to assure accurate operation. The calibration verification process will verify component calibration and allow adjustments to the flowsensor(s) and feedback sensor display readings to allow for variations in apparatus piping configuration and end user selected foam concentrate(s). Default values for simulated flow and foam concentrate injection rates can be set to end user specifications while in the calibration mode.

NOTE: The Hale FoamMaster system is calibrated at the factory to U.S. measurement (GPM, PSI, GALLONS, etc.) units. The system may be calibrated to any unit of measure, i.e. U.S., Metric, Imperial, etc. The same unit of measurement must be used throughout the calibration process to ensure proper proportioning by the system.

Recalibration of the system should be required **ONLY** after major repairs or component changes to the Hale FoamMaster foam system or if different viscosity foam concentrates are used.

SYSTEM USER CALIBRATION MODE

System user calibration is accomplished by using the control unit function buttons.

To enter system user calibration mode press and hold the **SELECT DISPLAY** button, then simultaneously press and release the **↑** and **↓**

↓ buttons. The display will show "CALib" (See figure 3-3) for several seconds followed by "C 0" and **FLOW LED**. (See figure 3-4)

To exit system user calibration mode and lock the settings press and hold the **SELECT DISPLAY** button, then simultaneously press and release the **↑** and **↓** buttons. The word "HALE" will appear for several seconds followed by the default display.

FACTORY DEFAULT VALUES

During calibration it may be desired to return the simulated flow rate or concentrate injection rate(s) to the original factory default settings. To return to the factory default values enter system user calibration mode as previously described. While calibrating the particular item simply depress the **↑** and **↓** simultaneously. This action will return the value displayed to the factory default setting. Proceed with calibration after performing this reset.

Factory default values are:

Simulated Flow: 150 GPM (568 LPM)
% FOAM: 0.5% Class A (Tank A)
1.0% Class B (Tank B) (If so equipped)

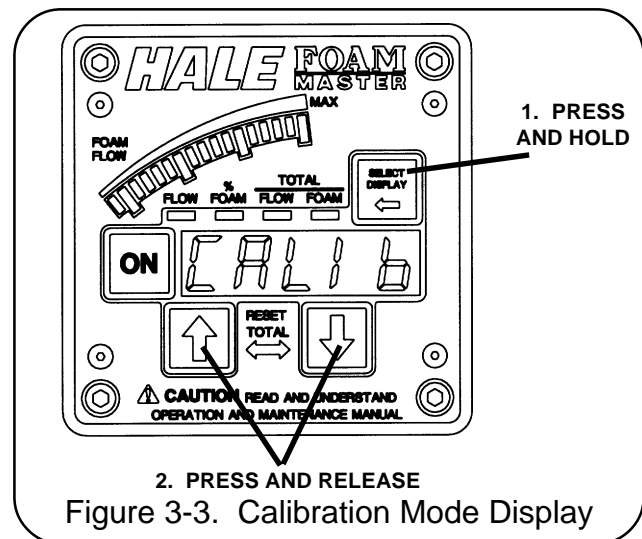

FLOWSENSOR CALIBRATION

NOTE: The flowsensor is calibrated at Hale Products Inc. and matched to the control unit. If the system is installed properly only minor adjustments should be necessary to flowsensor reading. Flowsensor calibration should be verified during NFPA/UL testing of apparatus and delivery to end user.

NOTE: An accurate flow measuring device must be used to measure the water flow when calibrating the flowsensor(s). Use a suitable size smooth bore nozzle and an accurate Pitot Gauge instrument. Hand held pitot gauges are usually not very accurate. Make sure the system is calibrated with an accurate flow measuring device.

Determine the water flow normally expected from the discharge outlet and establish flow. Make sure the water flow established is within the range of the flowsensor monitoring the discharge. For example, actually establish a flow of 150 GPM (568 LPM) of water through a nozzle and Pitot system. Compare the calculated flow value to the value shown on the control unit digital display.

If the value requires adjustment do the following:

Enter system user calibration mode using the method previously described. Press the **SELECT DISPLAY** button to illuminate the LED under **FLOW**. The current water flow rate preceded by a "C" will be displayed (See figure 3-4). Press the **↑** or **↓** button to set the reading to match the actual flow calculated from the Pitot gauge reading. Decrease fire pump pressure by approximately $\frac{1}{2}$ and recalculate water flow rate. Verify the reading on the control unit is within 5% of the actual value. Stop the water flow when the reading adjustments are completed.

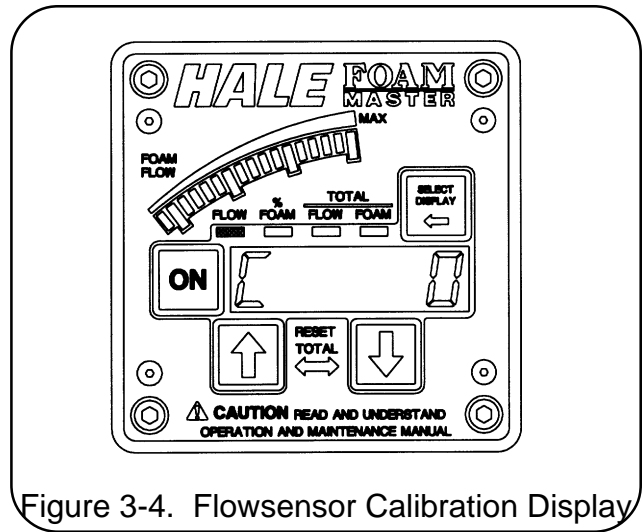

Figure 3-4. Flowsensor Calibration Display

To lock the settings, exit system user calibration mode by pressing and holding the **SELECT DISPLAY** button, then pressing and releasing the **↑** and **↓** buttons. The word "HALE" will appear for several seconds followed by the default display.

FOAM CONCENTRATE INJECTION RATE

When the Hale FoamMaster system power is turned on, the foam concentrate injection rate in memory will be the default injection rate setting. The user specific default concentrate injection rate can be adjusted in system calibration mode. Enter system user calibration mode as previously described.

Use the **SELECT DISPLAY** button to illuminate the LED below **% FOAM**. The display will show the current default concentrate injection rate stored in the computer memory for the selected foam concentrate tank (see figure 3-5). If the factory default values have not been changed the display will show "PA 0.5" for a single tank system or dual tank system with selector in the **TANK A** position. When a dual tank system is installed and the selector is placed in the **TANK B** position the display will show "Pb 1.0". The **↑** or **↓** buttons can be used to set the user specified default concentrate injection rate.

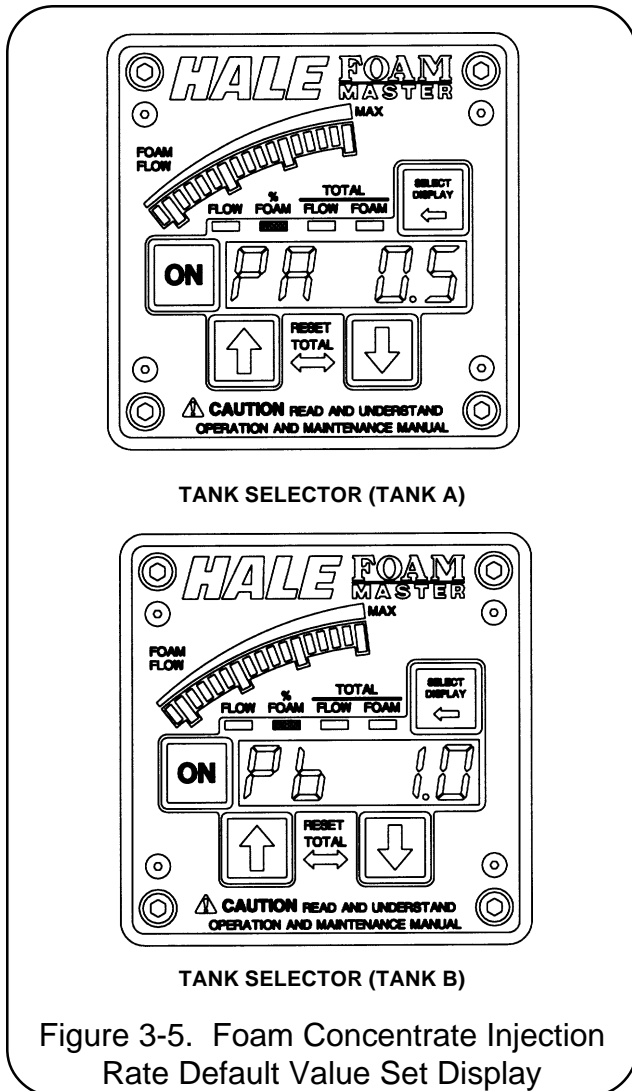

Figure 3-5. Foam Concentrate Injection Rate Default Value Set Display

If a dual tank system is installed set the default injection rate with the tank selector in the **TANK A** position then switch to the **TANK B** position to set concentrate injection rate for the foam concentrate in that particular tank.

If the ADT, MDT II or MST selector is in the **FLUSH** position the display will show "FLUSH" and the foam concentrate injection rate cannot be set.

To lock the settings, exit system user calibration mode by pressing and holding the **SELECT DISPLAY** button, then pressing and releasing the **↑** and **↓** buttons. The word "HALE" will appear for several seconds

followed by the default display.

FOAM PUMP FEEDBACK CALIBRATION

NOTE: Foam pump feedback is calibrated at Hale Products Inc. Calibration after installation is necessary to verify values with the actual foam concentrate(s) being used. Only check calibration using actual foam concentrates. **DO NOT** use water, training or test foams for feedback calibration verification.

Enter system user calibration mode using the method previously described. Press the **SELECT DISPLAY** button to illuminate the LED below **TOTAL FOAM** on the Control unit. The control unit display will show "x_xx" indicating the total volume of foam concentrate pumped during the last

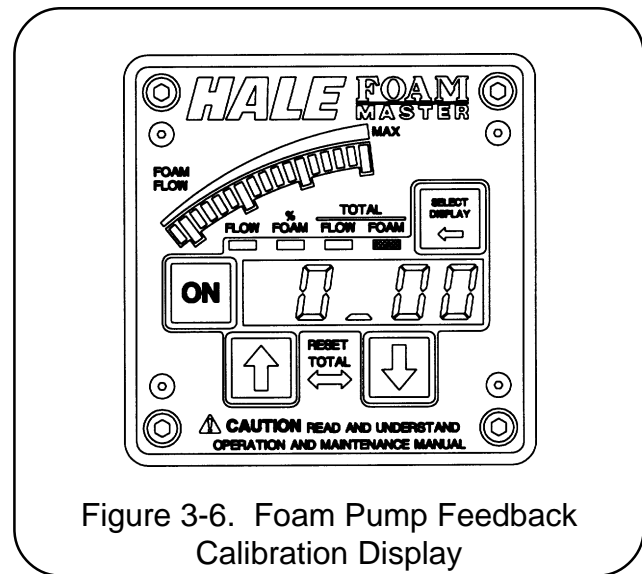

Figure 3-6. Foam Pump Feedback Calibration Display

calibration run (See figure 3-6).

Turn the bypass valve handle to the **BYPASS** position and place a graduated measure container at the outlet of the bypass hose that can contain the expected volume of foam concentrate, 5 gallons (19 liters) minimum (figure 3-7).

NOTE: If an accurate calibrated container is not available an accurate

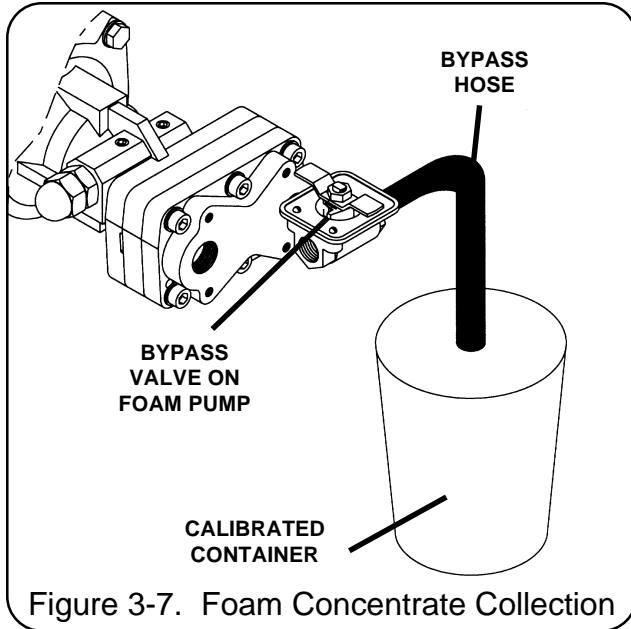

Figure 3-7. Foam Concentrate Collection

scale can be used to weigh the foam concentrate pumped. The total volume of foam concentrate can then be calculated from this weight and the density of the foam concentrate from the MSDS sheet.

Start the Hale FoamMaster foam pump by pressing the red **ON** button. The **ON** button will illuminate and the foam pump will operate at approximately $\frac{2}{3}$ speed to pump foam concentrate into the container. The display will show the volume of foam concentrate pumped. Stop the foam pump and measure precisely the amount of foam concentrate collected.

Adjust the reading on the display to the volume actually pumped by pressing the \uparrow or \downarrow button.

Repeat the procedure to verify the setting is correct.

When a dual tank system is installed switch to the other tank and repeat the procedure.

Turn the bypass valve handle back to INJECT position.

To lock the settings, exit system user calibration mode by pressing and holding the **SELECT DISPLAY** button, then pressing and releasing the \uparrow and \downarrow buttons. The word "HALE" will appear for several seconds followed by the default display.

SIMULATED FLOW

The default Simulated Flow value is factory set to 150 GPM (568 LPM) and, if necessary, the default value can be adjusted while in system user calibration mode. Enter system user calibration mode using the method previously described. Press the **SELECT DISPLAY** button until the LED under **TOTAL FLOW** is illuminated. The default simulated flow rate will be displayed as shown in figure 3-8. Adjust the setting by pressing the \uparrow or \downarrow buttons to set the desired rate, i.e., "S 150".

To lock the settings, exit system user calibration mode by pressing and holding the **SELECT DISPLAY** button, then pressing and releasing the \uparrow and \downarrow buttons. The word "HALE" will appear for several seconds followed by the default display.

The above procedures complete verification and adjustment of the system. The Hale FoamMaster system is now ready to be placed in service.

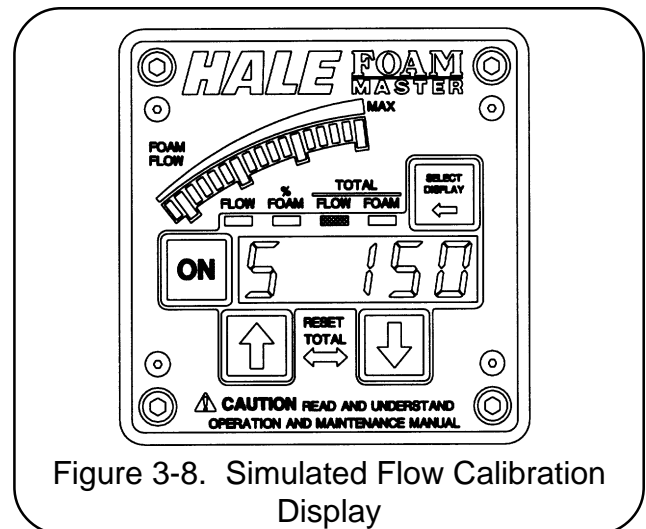

Figure 3-8. Simulated Flow Calibration Display

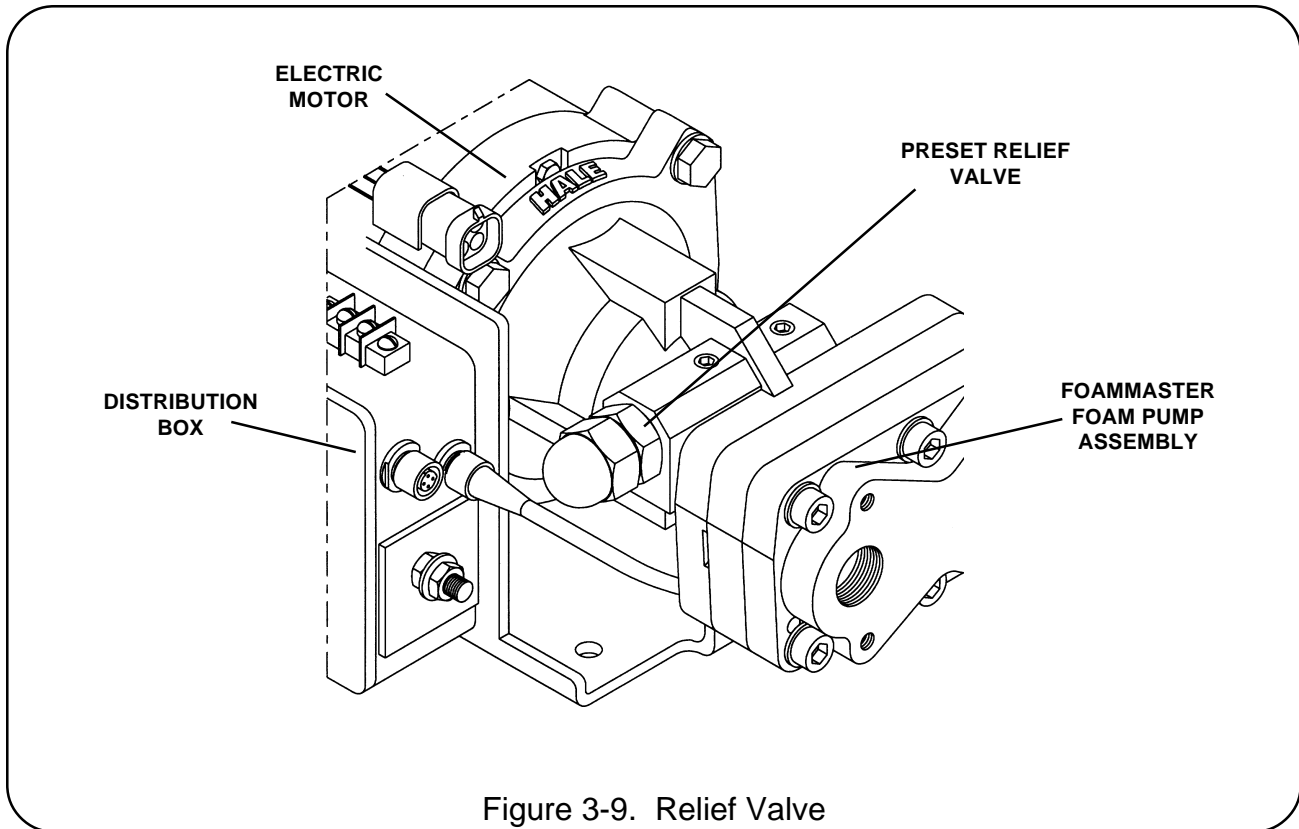

Figure 3-9. Relief Valve

RELIEF VALVE

The pressure relief valve (see figure 3-9) is factory tested and set to values shown in the following table. During normal installation and operation the relief valve will not require adjustment. If adjustment is necessary in field installation contact Hale Products Inc for Relief Valve Service bulletin.

HALE FOAMMASTER MODEL	RELIEF VALVE SET PRESSURE
MODEL 5.0	300 PSI (21 BAR)
MODEL 3.3	400 PSI (28 BAR)
MODEL 3.0	250 PSI (17 BAR)

HALE

FOAM MASTER

ROTARY GEAR PUMP ELECTRONIC FOAM PROPORTIONING SYSTEM

DESCRIPTION, INSTALLATION AND OPERATION
MANUAL

SECTION IV OPERATION

NOTICE: This manual section is primarily used by the apparatus end user for proper operation and maintenance of the Hale FoamMaster system. This manual section can be used as a stand alone section or in conjunction with other sections of the complete manual.

HALE PRODUCTS, INC. • A Unit of IDEX Corporation • 700 Spring Mill Avenue • Conshohocken, PA 19428 • TEL: 610-825-6300 • FAX: 610-825-6440



Hale Products cannot assume responsibility for product failure resulting from improper maintenance or operation. Hale Products is responsible only to the limits stated in the product warranty. Product specifications contained in this material are subject to change without notice.



SAFETY

Hale FoamMaster systems are designed to provide reliable and safe foam concentrate injection. Before installing or operating a Hale FoamMaster system read all safety precautions and follow carefully to ensure proper installation and personnel safety.

WARNINGS

1. Do not permanently remove or alter any guard or insulating devices or attempt to operate the system when these guards are temporarily removed.
2. To prevent electrical shock always disconnect the primary power source before attempting to service any part of the Hale FoamMaster system.
3. All electrical systems have the potential to cause sparks during service. Take care to eliminate explosive or hazardous environments during service/repair.
4. To prevent system damage or electrical shock the main power supply wire will be the last connection made to the Hale FoamMaster distribution box.
5. Release all pressure then drain all concentrate and water from the system before servicing any of its component parts.
6. Rotating drive line components can cause injury. When working on components of the Hale FoamMaster system be careful of rotating components.
4. Hale FoamMaster systems are designed for use on negative ground direct current electrical systems only.
5. Do not mount radio transmitter or transmitter cables in direct or close contact with the Hale FoamMaster unit.
6. Before connecting the cordsets inspect the seal washer in the female connector. If the seal washer is missing or damaged, water can enter the connector causing corrosion of the pins and terminals resulting in possible system failure.
7. Always disconnect the power cable, ground straps, electrical wires and control cables from the control unit or other Hale FoamMaster equipment before electric arc welding at any point on the apparatus. Failure to do so could result in a power surge through the unit that could cause irreparable damage.
8. **DO NOT** connect the main power lead to small leads that are supplying some other device such as a light bar or siren. The Hale FoamMaster Model 3.3 and Model 5.0 require 60 AMP minimum current. The Hale FoamMaster Model 3.0 requires 40 AMP minimum current. Use correct gauge wire as specified.

CAUTIONS

1. Foam tank low level sensors must be utilized to protect the Hale FoamMaster from dry running. Failure to use low level sensors with the Hale FoamMaster system will void warranty.
2. Do not operate system at pressures higher than the maximum rated pressure.
3. Use only pipe, hose, and fittings from the foam pump outlet to the injector fitting, which are rated at or above the maximum pressure rating at which the water pump system operates.
9. When operating the Hale FoamMaster in Simulated Flow mode an outlet for the foam concentrate must be provided to prevent excessive pressure buildup in discharge piping or hoses.
10. Unless engaged in Class B foam operations, the Hale FoamMaster ADT toggle switch or Hale FoamMaster MDT II selector handle must be in the **TANK A** position. If the toggle switch or selector handle is in the **FLUSH** position when the Hale FoamMaster foam pump is started the foam pump will only run for 20 seconds and shut down.

11. Make sure the foam tank and foam concentrate suction hoses are clean before making final connection to foam pump. If necessary flush tank and hoses prior to making connection.

NOTES

1. Check all hoses for weak or worn conditions after each use. Ensure that all connections and fittings are tight and secure.
2. Ensure that the electrical source of power for the unit is a negative ground DC system, of correct input voltage, with a reserve minimum current available to drive Hale FoamMaster system.
3. The in-line strainer/valve assembly is a low pressure device and WILL NOT withstand flushing water pressure. When installing the in-line strainer in systems equipped with Hale MDT II or Hale MST make sure the in-line strainer/valve assembly is in the hose on the inlet side of the valve. If the strainer will be subject to flushing water pressure, use Hale FS series strainers.
4. When determining the location of Hale FoamMaster components keep in mind piping runs, cable routing and other interferences that will hinder or interfere with proper system performance.
5. The Hale HPF flowsensor is assembled and tested at the factory. Removal of the flow sensor from the tee is not necessary or recommended for installation in the system.
6. Always position the check valve/injector fitting at a horizontal or higher angle to allow water to drain away from the fitting. This will avoid sediment deposits or the formation of an ice plug.
7. The cordsets provided with each Hale FoamMaster system are 100% electrically shielded assemblies. Never attempt to shorten or lengthen the molded cables. If necessary order longer or shorter cordsets from Hale Products to suit the particular installation.
8. The cordsets provided with each Hale FoamMaster system are indexed so they

only go in the correct receptacle and they can only go in one way. When making cordset connections DO NOT force mismatched connections as damage can result in improper system operation.

9. The system can only perform when the electrical connections are sound, so make sure each one is correct.
10. The cables shipped with each Hale FoamMaster system are 100% tested at the factory with that unit. Improper handling and forcing connections can damage these cables which could result in other system damage.
11. There are no user servicable parts inside Hale FoamMaster system electrical/electronic components. Opening of these components (distribution box, control unit, foam discharge multiplexing display unit) will void warranty.
12. Use mounting hardware that is compatible with all foam concentrates to be used in the system. Use washers, lockwashers and capscrews made of brass or 300 series stainless steel.
13. When making wire connections make sure they are properly insulated and sealed using an adhesive filled heat shrink tubing.
14. Before running wires from the low tank switches to the A-B switch box make sure the wire from Tank A is identified and properly labeled.
15. **ALWAYS** connect the primary positive power lead from the terminal block to the master switch terminal or the positive battery terminal using minimum 4 AWG type SGX (SAE J1127) chemical resistant battery cable and protect with wire loom.
16. Prevent corrosion of power and ground connections by sealing these connections with silicone sealant provided.
17. Prevent possible short circuit by using the rubber boot provided to insulate the primary power connection at the Hale FoamMaster distribution box.

OPERATING INSTRUCTIONS

SYSTEM OPERATION DESCRIPTION

Operation of Hale FoamMaster systems is simple with all control provided by the push buttons on the control unit face (see figure 4-1).

Upon initial power up of the apparatus the Hale FoamMaster system will go to the standby mode upon completion of a self diagnostic routine. There are four different display functions on the control unit digital display. While in standby mode with the **FLOW** LED lit the digital readout will show the current water flow rate in the monitored discharge pipe. Pressing the **SELECT DISPLAY** button will change the function indicated by the LED that is lit under a particular label.

TOTAL WATER and **TOTAL FOAM** values can be reset any time they are displayed. When the **% FOAM** LED is lit, or in any other function mode, the foam concentrate injection rate can be set to the desired value, if different from the default value, prior to or during

foam operations by pressing the **↑** and **↓** buttons.

When the red **ON** button is pressed, the button will illuminate indicating that the system is ready. If water flow is present the foam pump will start and inject foam concentrate into the discharge stream. The bargraph will light when foam is being injected and indicate system capacity. The Hale FoamMaster system constantly monitors water and foam concentrate flow values maintaining foam injection at the specified concentrate injection rate. The system responds to variations in water flow by increasing or decreasing the speed of the foam pump.

When the **ON** button is again pressed, the button will extinguish, indicating that the system is in Stand-By mode and the foam pump will stop, but other system monitoring functions will continue.

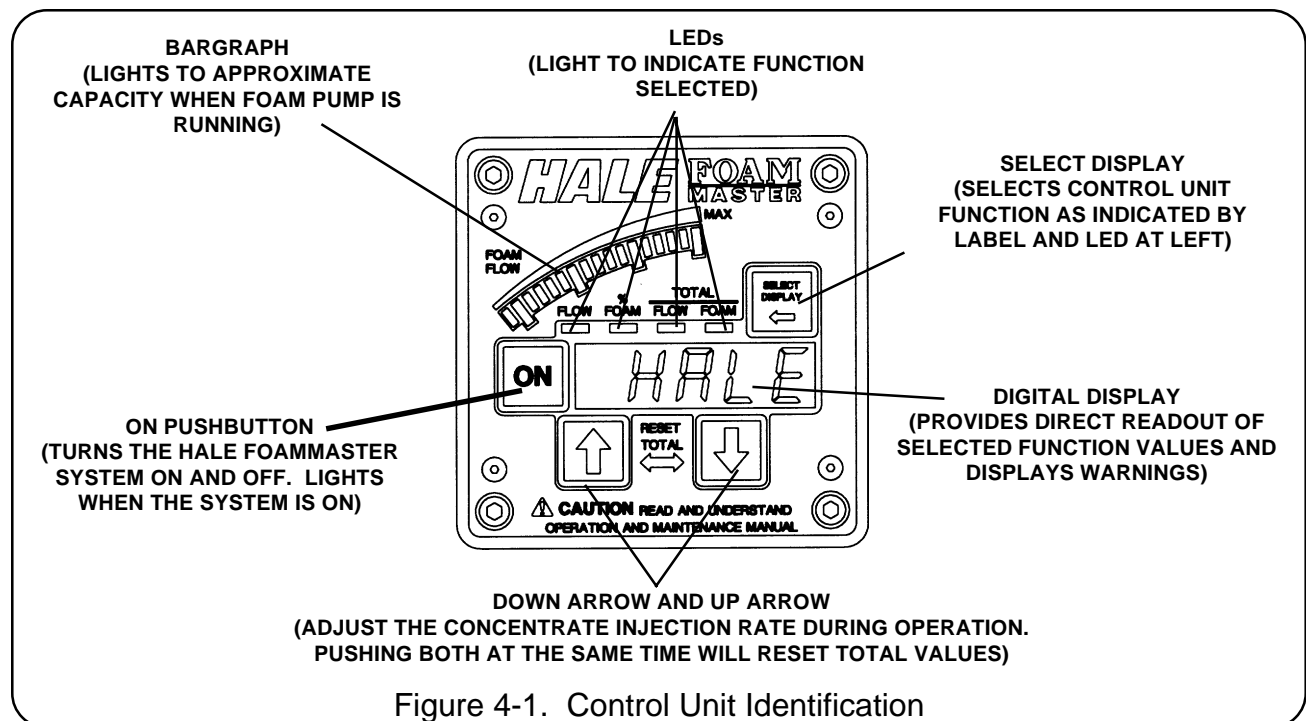

Figure 4-1. Control Unit Identification

DISPLAY INFORMATION

The five digit display on the control unit shows the value of the selected display function or provides warnings to the operator when the system is operating. A function is selected by pressing the grey **SELECT DISPLAY** button in the upper right hand corner of the control unit. Each time the button is pressed a new function mode is selected and displayed. LEDs above the digital display denote which function is being displayed. Pressing the **SELECT DISPLAY** button changes the control unit function but does not affect injection rate.

Control unit functions include:

FLOW

The display shows the current flow rate of water or foam solution per minute in Hale HPF flowsensor monitored discharges. (See figure 4-2)

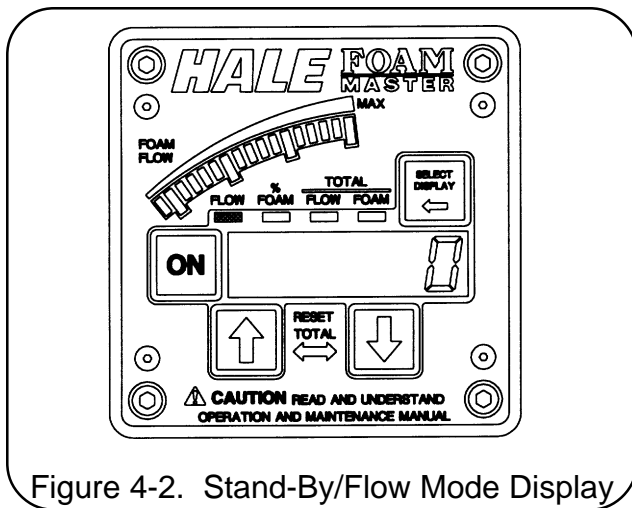

% FOAM

The display shows the foam concentrate injection rate setting in the % FOAM mode. For example, with a single tank system or when the dual tank system selector is in the **TANK A** position the display will show "A 0.5". When the dual tank system selector is in the **TANK B** position the display will show "b 1.0". (See figure 4-3) When the system is equipped with MST, MDT II or ADT and

the selector is in the flush position the display reads "FLUSH".

TOTAL FLOW

The display shows the total amount of water or foam solution pumped through flowsensor monitored discharges. This totalized value may be reset using procedures outlined in the "Reset Functions" paragraph.

TOTAL FOAM

The display shows the total amount of foam concentrate pumped. The value will be in the same unit of measure as the water flow. This totalized value may be reset using procedures outlined in the "Reset Functions" paragraph. As an example the display may show "9.5" indicating 9.5 gallons of foam

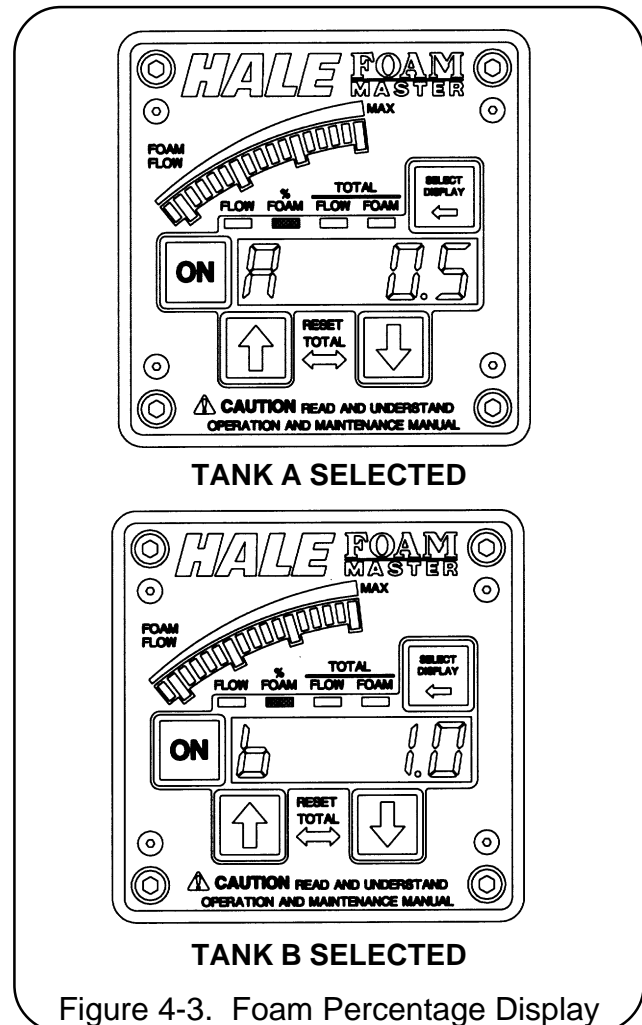

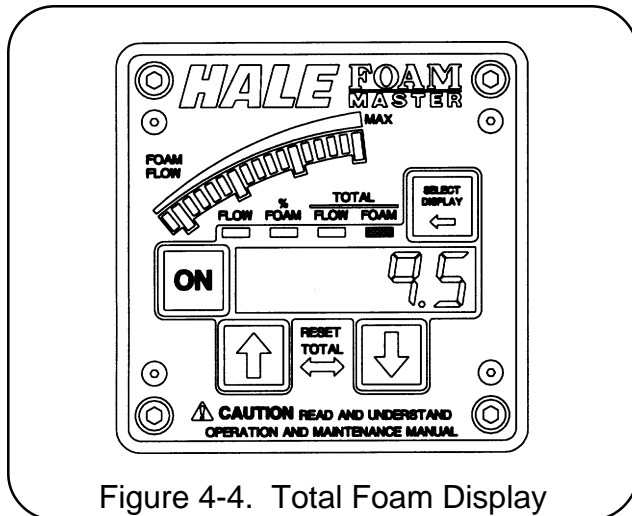

Figure 4-4. Total Foam Display

concentrate have been used. (See figure 4-4)

BARGRAPH

The bargraph (refer to figure 4-1) consists of 17 LEDs. The LEDs on the bargraph will light when the foam pump is running and injecting foam concentrate. The amount of LEDs lighted provides an indication of the approximate pump capacity being used.

If water flow requirements exceed the capacity of the pump to deliver foam concentrate, the pump will run at maximum rate. All bargraph LEDs light and the uppermost LED flashes warning the operator that the system capacity is being exceeded and is running "lean" on foam concentrate percentage.

If the flow decreases such that the required injection rate is less than the lowest rating of the pump, the pump will run at its minimum rate and the first bargraph LED flashes so the operator will know the system is running "rich" on foam percentage.

RESET FUNCTIONS

The totalized values for water and foam concentrate pumped can be cleared from memory by performing a RESET function. Using the **SELECT DISPLAY** button, select either **TOTAL WATER** or **TOTAL FOAM**. By pressing and holding both the **↑** and **↓**

buttons at the same time, the value shown is cleared and displayed as zero. Additionally the totalized values for water and foam concentrate reset to zero automatically when the apparatus power is turned off.

FOAM CONCENTRATE INJECTION RATE

When **% FOAM** is selected, the **↑** and **↓** buttons will respectively increase or decrease foam concentrate percentage.

While operating in any function, with the exception of **FLOW** during simulated flow operation, whenever the **↑** or **↓** buttons are momentarily pressed, the display will switch to the **% FOAM** display and show the current injection rate for 2 seconds. In any display mode, if either the **↑** or **↓** button is held down for a period of 2 seconds or more, the injection rate value will increase or decrease accordingly. Once released, the display will return to the last selected display after 2 seconds. When a reset (pressing both the **↑** and **↓** buttons at the same time) is performed in the **% FOAM** display mode the foam concentrate injection rate is returned to the default value.

WARNING MESSAGES

Several safety features are incorporated into the Hale foamMaster system to protect the foam concentrate pump, electric motor and apparatus wiring while maintaining personnel safety. Messages appearing on the display alert the operator to adverse conditions that could cause damage to Hale FoamMaster system components, the apparatus and cause personnel injury.

FLUSH

If the Hale FoamMaster system is equipped with ADT, MDT II or MST and the operating controls for these selectors are in the **FLUSH** position the foam pump motor will increase to approximately 80% capacity. The system will operate for 20 seconds when water is flowing then go to standby mode.

When in **FLOW** or **TOTAL FLOW** mode the display will alternate between "FLUSH" (see figure 4-5) and the value of the selected function. These modes function normally when in FLUSH mode.

When in **% FOAM** or **TOTAL FOAM** mode "FLUSH" will show steady on the display. These modes will not function while in FLUSH mode.

Low Foam Tank Level

The Hale FoamMaster foam pump is interlocked with the foam concentrate tank level switch(es). If the tank is empty, the pump will run for 1 minute. Low foam concentrate tank level is denoted by "Lo A" or "Lo b" (see figure 4-6) alternating with the normal selected function on the display. If one minute of low concentrate level is detected the display will show "no A" or "no b", the pump will stop, and the **ON** LED

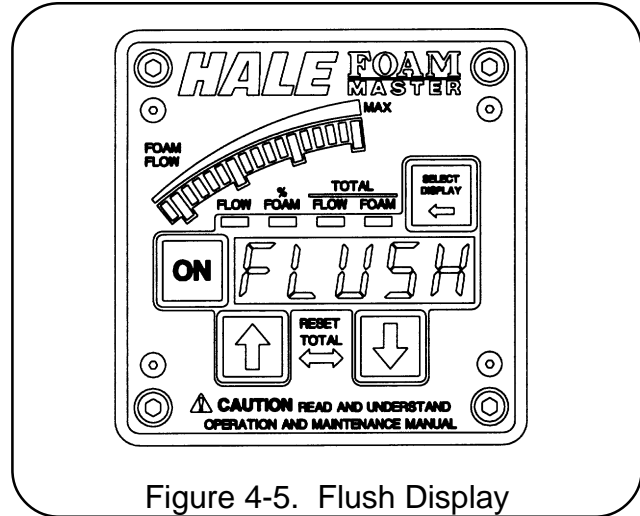

Figure 4-5. Flush Display

will go out until the foam level is restored and the **ON** button is depressed. If the **ON** button is pressed before refilling the foam tank the system will run for 30 seconds before shutting down again.

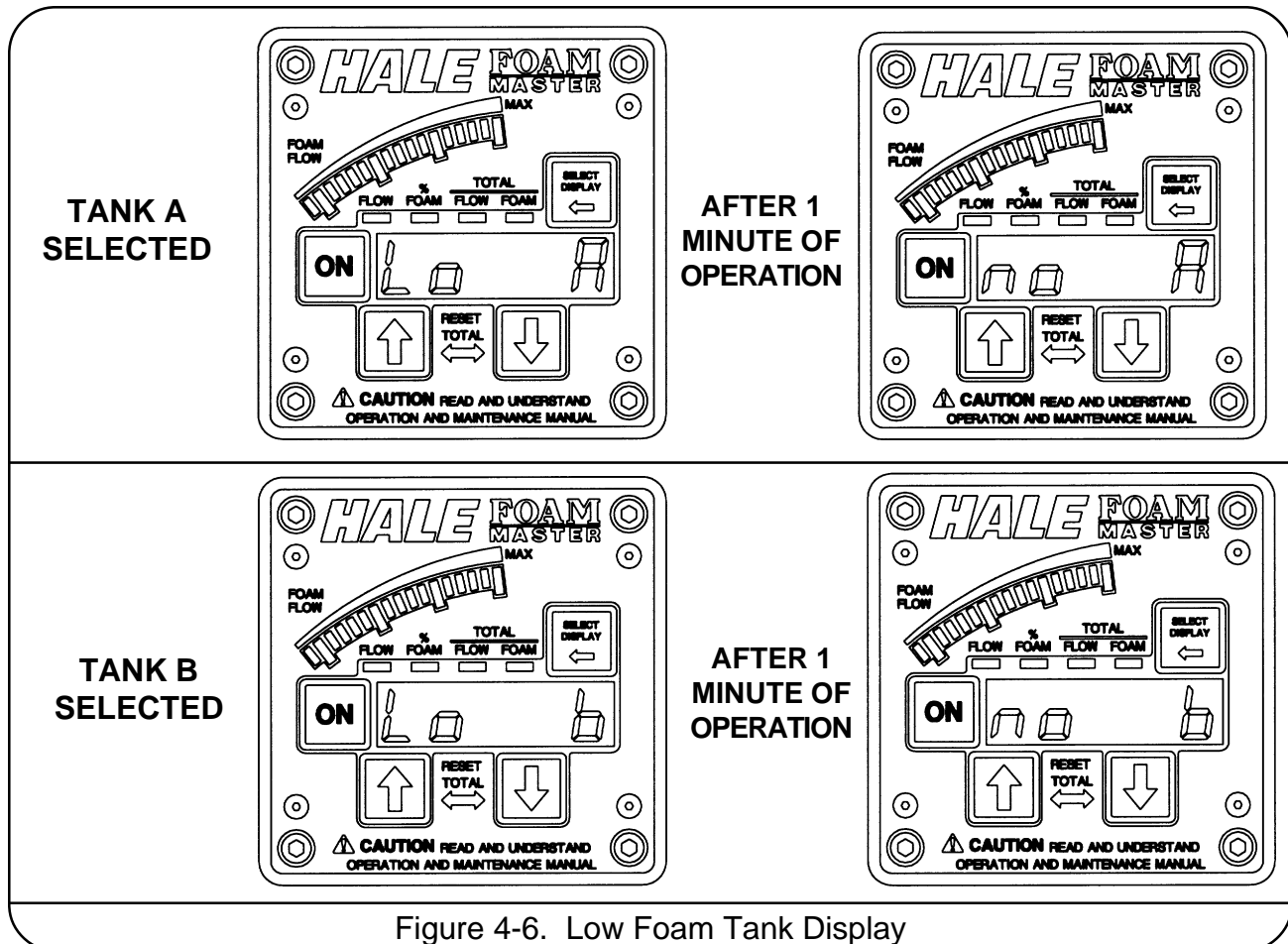

Figure 4-6. Low Foam Tank Display

Priming Error

In the event there is no feedback signal being received when the foam pump is started, indicating a lack of foam concentrate flow, the foam pump motor will run at full speed to attempt to establish foam concentrate flow. If the system operates for a period of 30 seconds without a feedback signal the system will go to the standby mode and the display will flash "noPri" (no prime) indicating there is no foam concentrate flow. (See figure 4-7)

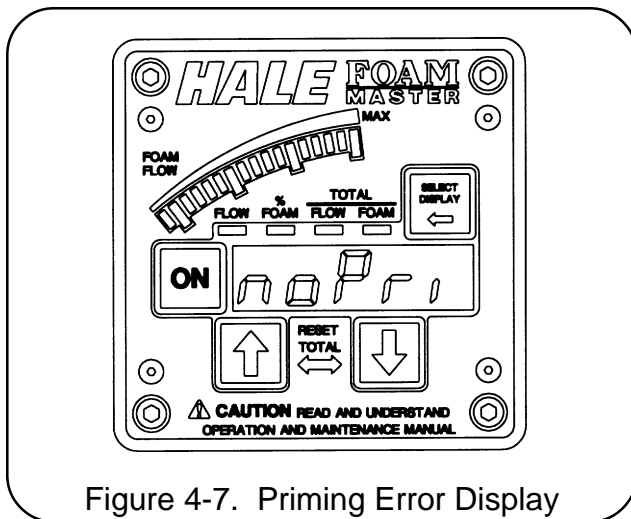

Figure 4-7. Priming Error Display

High Ambient Temperature

In the event the Hale FoamMaster system is operating in an environment of excessive ambient temperature the display will show "hot" to indicate this situation (see figure 4-8). If the circuitry in the Hale FoamMaster system is being affected by a drop in power supply voltage the display will show "LobAt" to indicate this situation.

NOTE: This is not necessarily an indication of apparatus battery level or condition. This is only an indication of adverse operating conditions. For instance a bad battery cable can cause the system to see low power even though the batteries are fully charged.

In either case the system will continue to run with these adverse conditions. If conditions deteriorate to the point of potential system damage due to heat or low power the system will return to the standby and error message will remain until **ON** is pushed again.

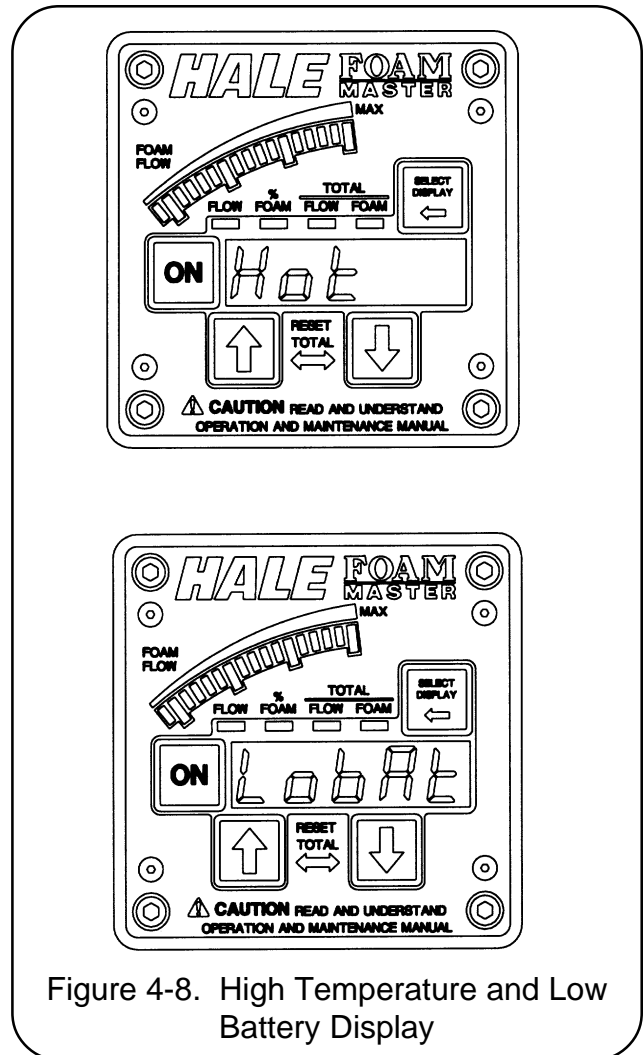
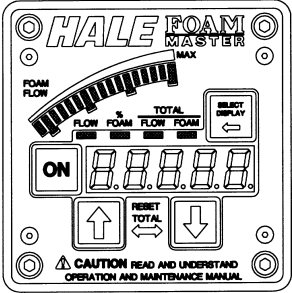
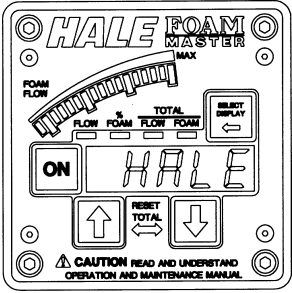
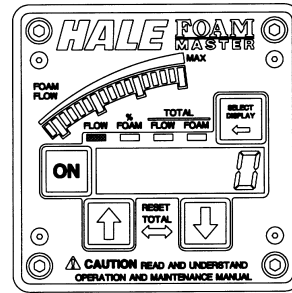
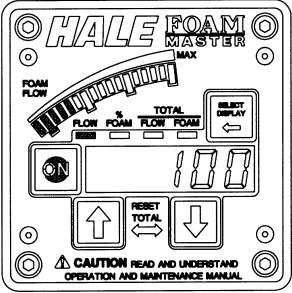
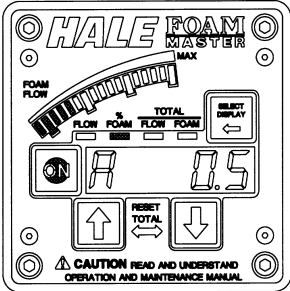
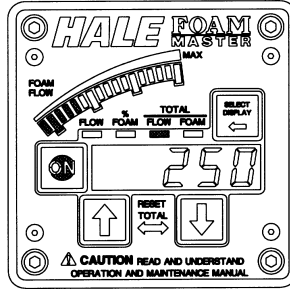
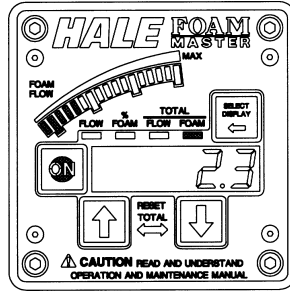
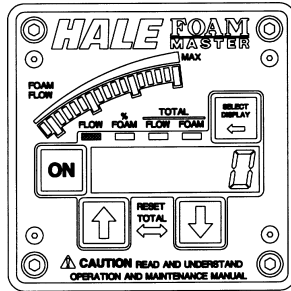

Figure 4-8. High Temperature and Low Battery Display

NORMAL OPERATION SUMMARY

OPERATION	ACTION	DISPLAY
Energize System	Energize apparatus and turn FoamMaster power switch to ON .	 <p>INITIAL STARTUP</p>  <p>SELF DIAGNOSTICS</p>  <p>STAND-BY DISPLAY SINGLE FLOWSENSOR: FLOW MULTIPLE FLOWSENSORS: % FOAM</p>
Begin Foam Injection	Establish water flow and depress ON button.	 <p>WATER FLOW ESTABLISHED, ON BUTTON PRESSED</p>

OPERATION	ACTION	DISPLAY
<p>Change injection rate</p> <p>Read injection rate</p>	<p>Press ↑ or ↓ and hold for 2 seconds. Release once desired rate is set.</p> <p>Press and release ↑ or ↓. Display will show injection rate and return to selected function after 2 seconds.</p>	 <p style="text-align: center;">FOAM CONCENTRATE INJECTION RATE DISPLAY</p>
<p>Read total water or foam solution</p>	<p>Press SELECT DISPLAY until LED below TOTAL FLOW is lit.</p>	 <p style="text-align: center;">TOTAL FLOW DISPLAY</p>
<p>Read total foam concentrate</p>	<p>Press SELECT DISPLAY until LED below TOTAL FOAM is lit.</p>	 <p style="text-align: center;">TOTAL FOAM DISPLAY</p>
<p>Reset Totalized values</p>	<p>While in TOTAL FLOW or TOTAL FOAM press and release ↑ and ↓.</p>	
<p>End foam injection</p>	<p>Depress ON button.</p>	 <p style="text-align: center;">STAND-BY DISPLAY SINGLE FLOWSSENSOR: FLOW MULTIPLE FLOWSSENSORS: % FOAM</p>

SIMULATED FLOW OPERATION

The Simulated Flow mode of the Hale Foammaster system allows the operator to operate the foam pump without discharging water through a foam capable discharge or when the flowsensor is not functioning. The simulated flow mode is used for draining the foam tank for cleaning, checking calibration of the feedback sensor, verifying foam pump operation or manually controlling foam injection if the flowsensor malfunctions. The factory default simulated flow rate is 150 GPM (568 LPM). The simulated flow rate and the concentrate injection percentage rate can be set by using the display readout and the rate adjustment buttons on the control unit while in simulated flow mode. The simulated flow function provides manual operation of the foam injection system required by NFPA standards.

CAUTION: When operating the Hale FoamMaster in Simulated Flow mode an outlet for the foam concentrate must be provided to prevent excessive pressure buildup in discharge piping or hoses.

Use the following procedure to operate the Hale FoamMaster system using simulated flow:

1. Locate the bypass hose and uncoil to place the end into a suitable container to collect the foam concentrate.
2. Place the Hale Foammaster system BYPASS valve in the BYPASS position.
3. Energize apparatus electrical system and turn Hale Foammaster power switch to ON.
4. When the Hale FoamMaster is in the standby mode, **FLOW** LED lit, depress and release the **↑** and **↓** buttons at the same time. The display will show "S 150" (or other pre-set default value) and the **FLOW** LED will be lit. (see figure 4-9)
5. Depress the **ON** button. The ON button will light and the foam pump will begin running. Foam concentrate will flow out of the end of the bypass hose.
6. To end simulated flow operation, first depress the **ON** button to stop the foam pump.
7. Press **SELECT DISPLAY** button until the **FLOW** LED is lit.

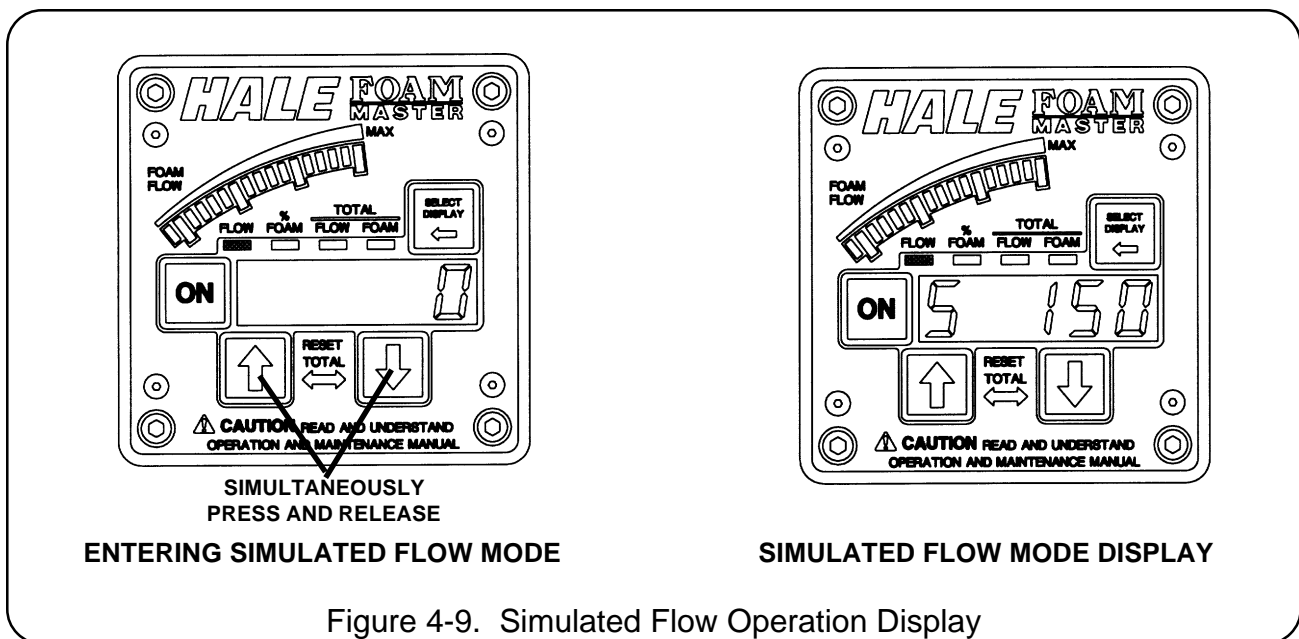

Figure 4-9. Simulated Flow Operation Display

8. Depress and release the ↑ and ↓ buttons at the same time. The display will show the current water flow value and the **FLOW** LED will be lit.
9. Deenergize apparatus electrical system.
10. Place the bypass valve to the INJECT position. Secure bypass hose in the appropriate compartment.
11. Return apparatus to normal ready condition.

TANK SELECTION WITH DUAL TANK SYSTEM

The following procedures are provided for operation of the Hale FoamMaster system with a Hale ADT or Hale MDT II Selector installed.

CAUTION: Unless engaged in Class B foam operations, the Hale FoamMaster ADT toggle switch or Hale FoamMaster MDT II selector handle must be in the **TANK A** position. If the toggle switch or selector handle is in the **FLUSH** position when the Hale FoamMaster foam pump is started the foam pump will only run for 20 seconds and shut down.

1. Make sure the Hale FoamMaster is operating and foam solution is being discharged.
2. Flip the Hale ADT toggle switch down or turn the Hale FoamMaster MDT II handle until the indicator points toward the desired tank (See figure 4-10). When changing toggle switch or selector handle position, move smoothly from the **TANK A** position through the **FLUSH** position to **TANK B** position in one motion without stopping. With the fire pump discharging water and the Hale FoamMaster operating, a small volume of water will be provided to separate the two foam types helping to prevent possible reactions.

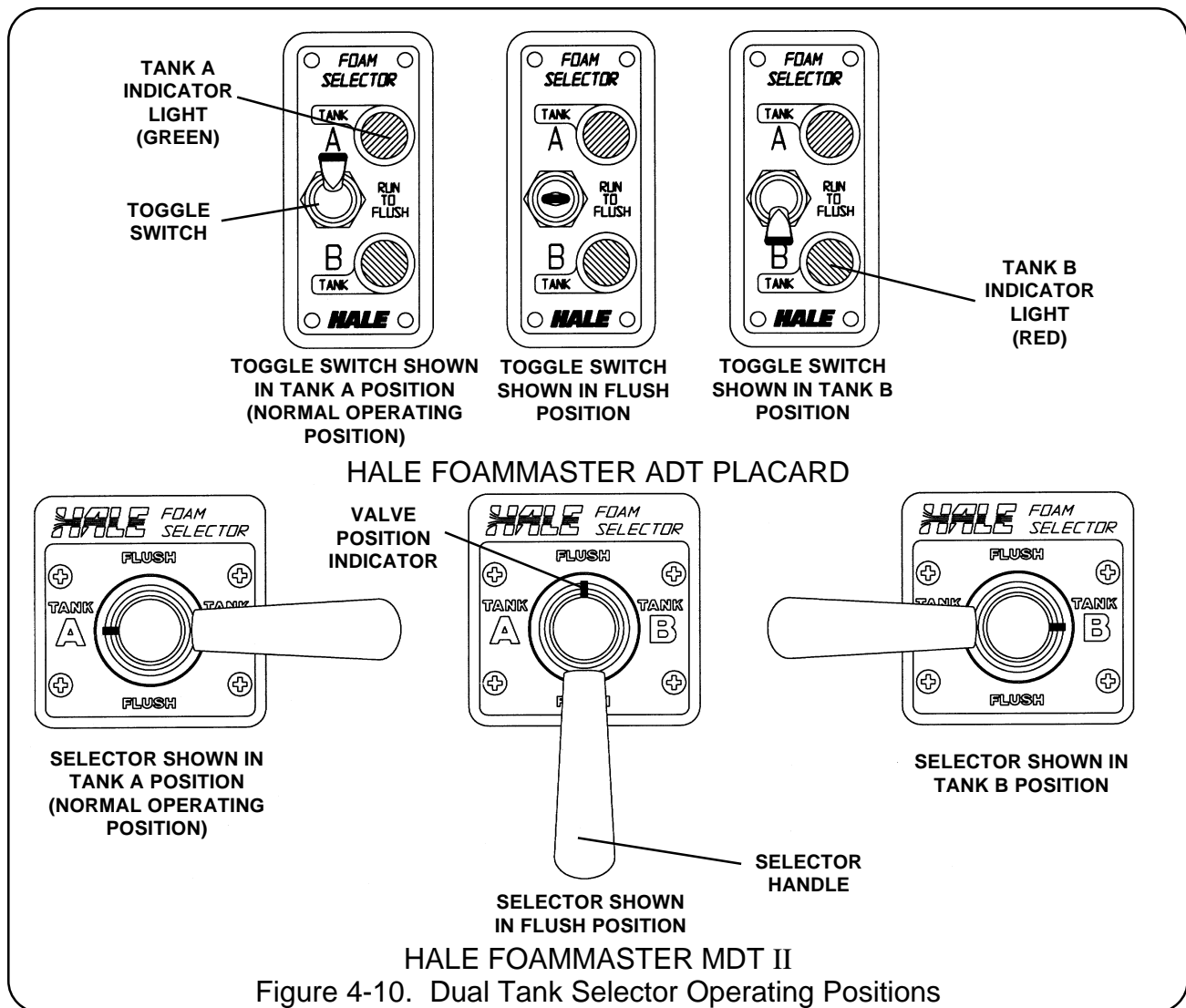

Figure 4-10. Dual Tank Selector Operating Positions

3. After completion of Class B foam operations briefly flush the foam pump and return the Hale FoamMaster to the ready condition by returning to the **TANK A** position and flowing a small amount of Class A foam concentrate.

IMPORTANT: Make sure the Hale FoamMaster dual tank system is in the **TANK A** position when apparatus is placed in ready condition.

FLUSHING HALE FOAMMASTER

When returning the apparatus to ready condition after foam operations using class B foam, the Hale FoamMaster foam pump must be flushed because some Class B foam concentrates deteriorate rapidly.

NOTE: Approved class A foam concentrates do not deteriorate rapidly like class B foam concentrates. As long as an approved class A foam concentrate is used and the system will be used within 10-12 weeks no flushing will be required. When class B foam concentrate is used flush system then switch to class A as most responses are usually class A types.

The following procedures shall be used to flush the foam pump. Refer to figure 4-10 for ADT or MDT II operating positions and refer to figure 4-11 for MST operation:

1. Energize apparatus and establish water flow through a foam capable discharge. Set fire pump for a low discharge pressure, 50 to 75 PSI (3.4 to 5.2 BAR).
2. Energize Hale FoamMaster by depressing the red **ON** button allowing foam solution to discharge.

NOTE: When the Hale ADT, MDT II or MST is in the **FLUSH** position the Hale FoamMaster foam injection system will only run for 20 seconds.

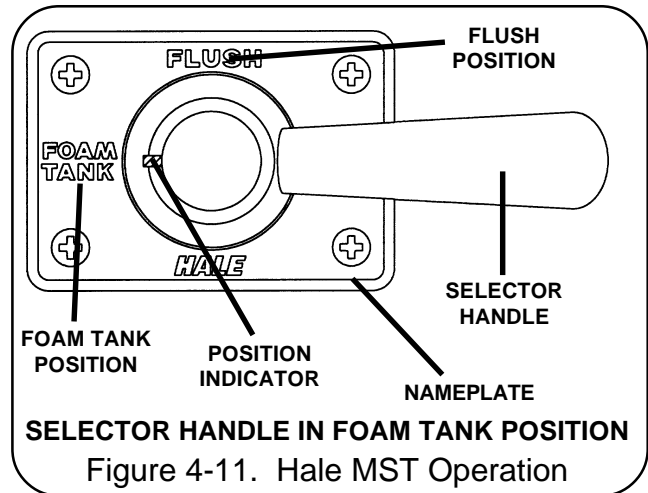

3. Place the Hale ADT, MDT II or MST to the **FLUSH** position.
4. Observe discharge hose and allow Hale FoamMaster and discharge to run for several seconds.
5. After several seconds place the Hale ADT or MDT II to the **TANK A** position and allow Hale FoamMaster to run until foam solution is discharged through the foam capable hose line.

NOTE: When the Hale MST is used for Class B foam concentrates DO NOT allow the foam pump to run in the **FOAM TANK** position after flushing foam pump.

6. Place the Hale MST to the **FOAM TANK** position and allow Hale FoamMaster to run until Class A foam solution is discharged through the foam capable hose line. If Class B foam concentrate is used shut down Hale FoamMaster immediately after switching to **FOAM TANK** position.
7. Shut down Hale FoamMaster allowing foam capable discharge to run to flush out the fire pump discharge manifold as required. Once clear water flows, close foam capable discharge and shut down apparatus.

8. Perform required maintenance checks on the Hale FoamMaster and apparatus to return the apparatus to ready condition.

IMPORTANT: Make sure the Hale ADT or MDT II is in the **TANK A** position and the Hale MST is in the **FOAM TANK** position when apparatus is placed in ready condition.

OPERATION WITH REMOTE ON/OFF SWITCH

The remote ON/OFF switch is used to activate the Hale FoamMaster system from the driver compartment or a location other than the control unit. The switch will only activate and deactivate the Hale FoamMaster system, it does not permit adjustment of the injection rate. Use the remote ON/OFF switch as follows:

1. Press the switch down and release to activate. The LED will light indicating the Hale FoamMaster is in the standby position.
2. When the foam capable discharge nozzle is opened the LED will blink indicating foam concentrate is being injected. When the nozzle is closed the LED will stop flashing.
3. Pressing the switch again will deactivate the Hale FoamMaster system and the LED will go out.

PRIMING THE FOAM PUMP WHEN FOAM TANK HAS RUN DRY

In some instances the foam tank may run dry while operating the Hale FoamMaster system. The foam pump is designed to pump liquid. When the fire pump is running the foam pump may not pump efficiently against 100 to 150 PSI (7 to 10 BAR) back pressure. To re-establish foam concentrate flow quickly the following procedure can be used.

1. Turn the bypass valve to the **BYPASS** position.
2. With the fire pump flowing water from foam discharge and the Hale FoamMaster on observe the hose from the bypass valve.
3. When foam concentrate flows from the hose turn the bypass valve back to the **INJECT** position. The pump is now primed and ready for normal operation.

MAINTENANCE

MAINTENANCE PROCEDURES

1. **After each use:** Flush Hale FoamMaster foam pump if class B foam concentrate was used and return to Class A.
2. **After each use:** Inspect wiring, hoses, flowsensors, and connections for tightness, corrosion, leaks and/or damage. Refer to installation drawings.
3. **After each use:** Remove and clean the foam strainer screen(s). Flush as required.

TROUBLESHOOTING

USER DIAGNOSTICS

Power indicator lamps are provided on the distribution box, on the rear of the control unit (see figure 4-12) and on the feedback sensor. The lamp on the distribution box located next to the ON/OFF switch is illuminated whenever power is supplied to the control cable. A similar lamp on the rear of the control unit is illuminated whenever power reaches the display. The LED on the feedback sensor will flash when the sensor is receiving pulses from the flowsensor. These LEDs help to ease tracing of power supply faults and eliminates some of the guesswork in troubleshooting. This feature is referenced in the troubleshooting guide.

If the system malfunctions make sure ALL the following conditions are met:

- ❑ All hose connections correct and tight (Refer to appropriate system plumbing diagram in Section II).
- ❑ All electrical connections correct and tight (Refer to appropriate system electrical diagram in Section II).
- ❑ Apparatus electrical system energized with power supplied to pump panel and Hale FoamMaster.
- ❑ Hale FoamMaster power switch located on the distribution box is in the ON position.
- ❑ Power indicator LEDs on the distribution box and control unit are illuminated.

Once all the above conditions are met proceed to the system troubleshooting section to determine cause of malfunction.

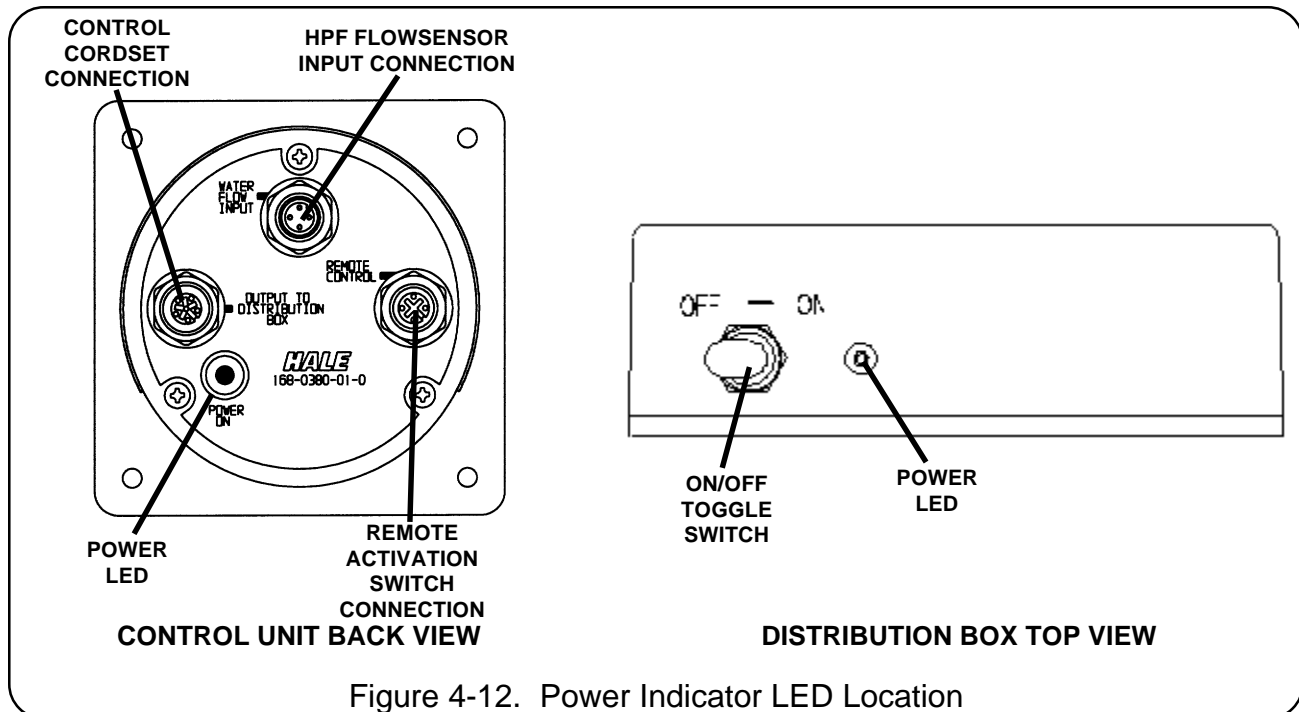

Hale FoamMaster systems consist of individual subsystems working together to provide finished foam solution at the proper percentage.

The entire system is designed using modular components making troubleshooting and repair easier. Each subsystem has its own set of troubleshooting procedures. The procedures that follow will provide a logical flow path to isolate and correct any system failure.

NOTE: Hale FoamMaster system electronic components have no user serviceable components and are replaced as a unit. Opening of Hale FoamMaster electronic components will void the manufacturer warranty.

PROBLEM ISOLATION

The first step in troubleshooting the Hale FoamMaster system is to determine which subsystem caused the overall system failure. To make this determination operate the apparatus and Hale FoamMaster system in accordance with standard operating procedures noting where problems occur.

Refer to the following to isolate the cause of Hale FoamMaster system failure.

Following are the basic steps to follow to isolate system problems. They are presented in block format in chart 4-1.

1. Setup apparatus for normal operation.
2. Power-up apparatus and energize the pump operator panel. Take notice of the Hale FoamMaster Control unit. If the display is NOT illuminated proceed to the power supply troubleshooting chart 4-2.
3. If the Hale FoamMaster control unit is illuminated engage apparatus water pump and establish discharge. If water flow CANNOT be established, troubleshoot the water pump system in accordance with pump troubleshooting procedures.
4. If there is no indication of water flow on control unit display troubleshoot flowsensor using procedures outlined in chart 4-3.
5. If water flow can be established turn Hale FoamMaster system ON to flow foam. Observe foam pump discharge, if foam is NOT flowing refer to foam pump troubleshooting chart 4-4.
6. Check accuracy of system using calibration procedures in Section III of this manual making adjustments as required.

Chart 4-1. Hale FoamMaster System Troubleshooting

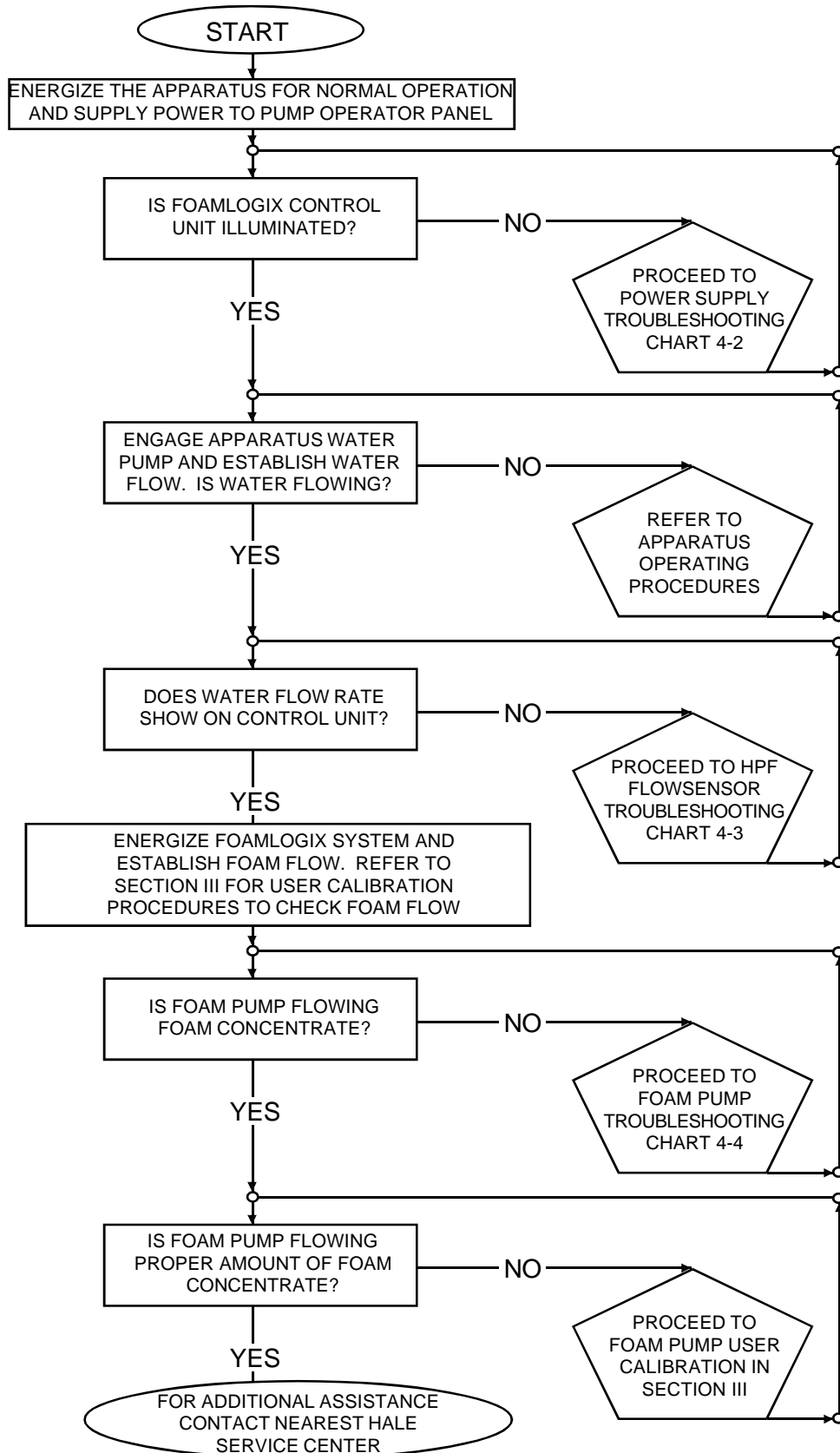

Chart 4-2. Power System Troubleshooting

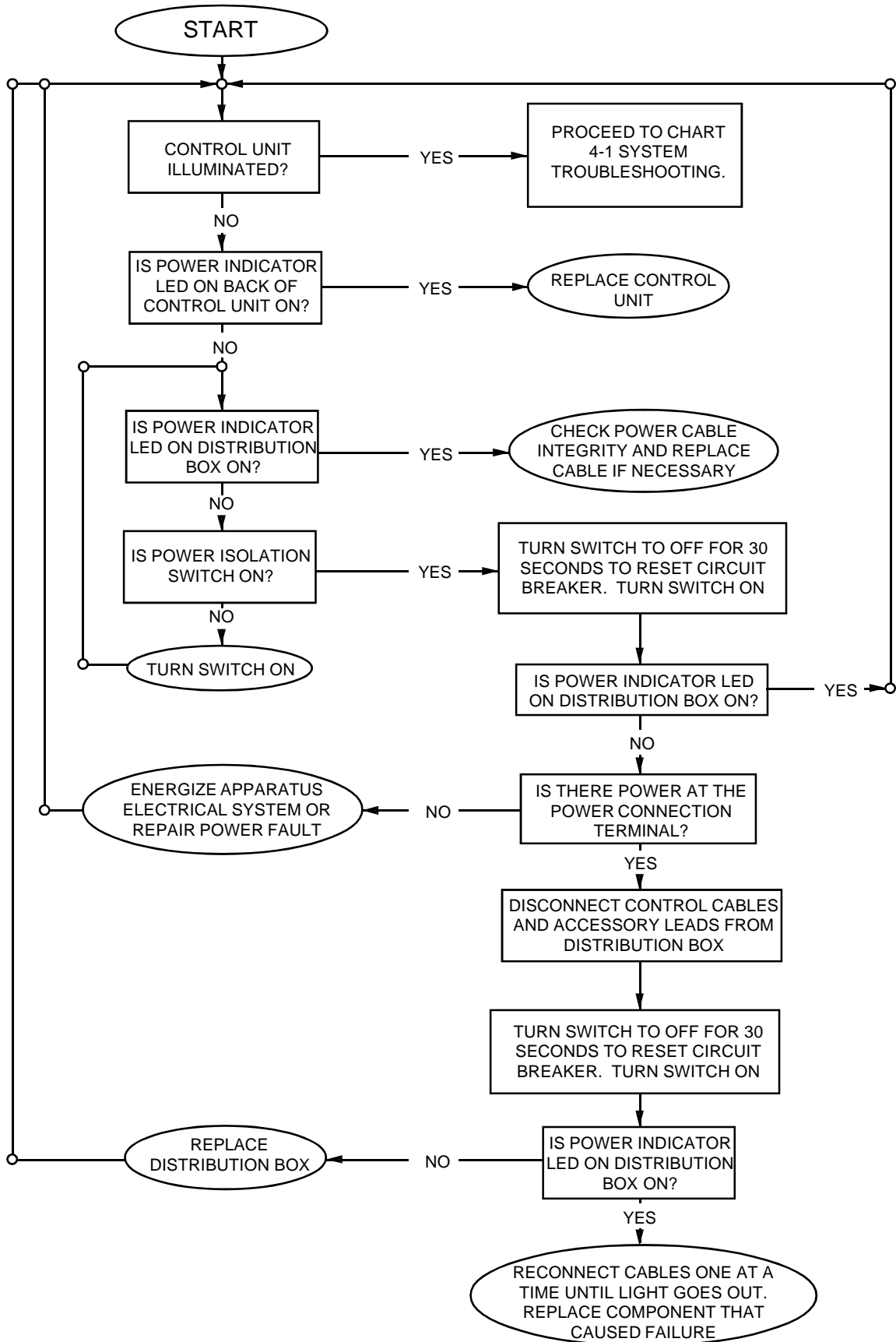

Chart 4-3. HPF Flowsensor Troubleshooting

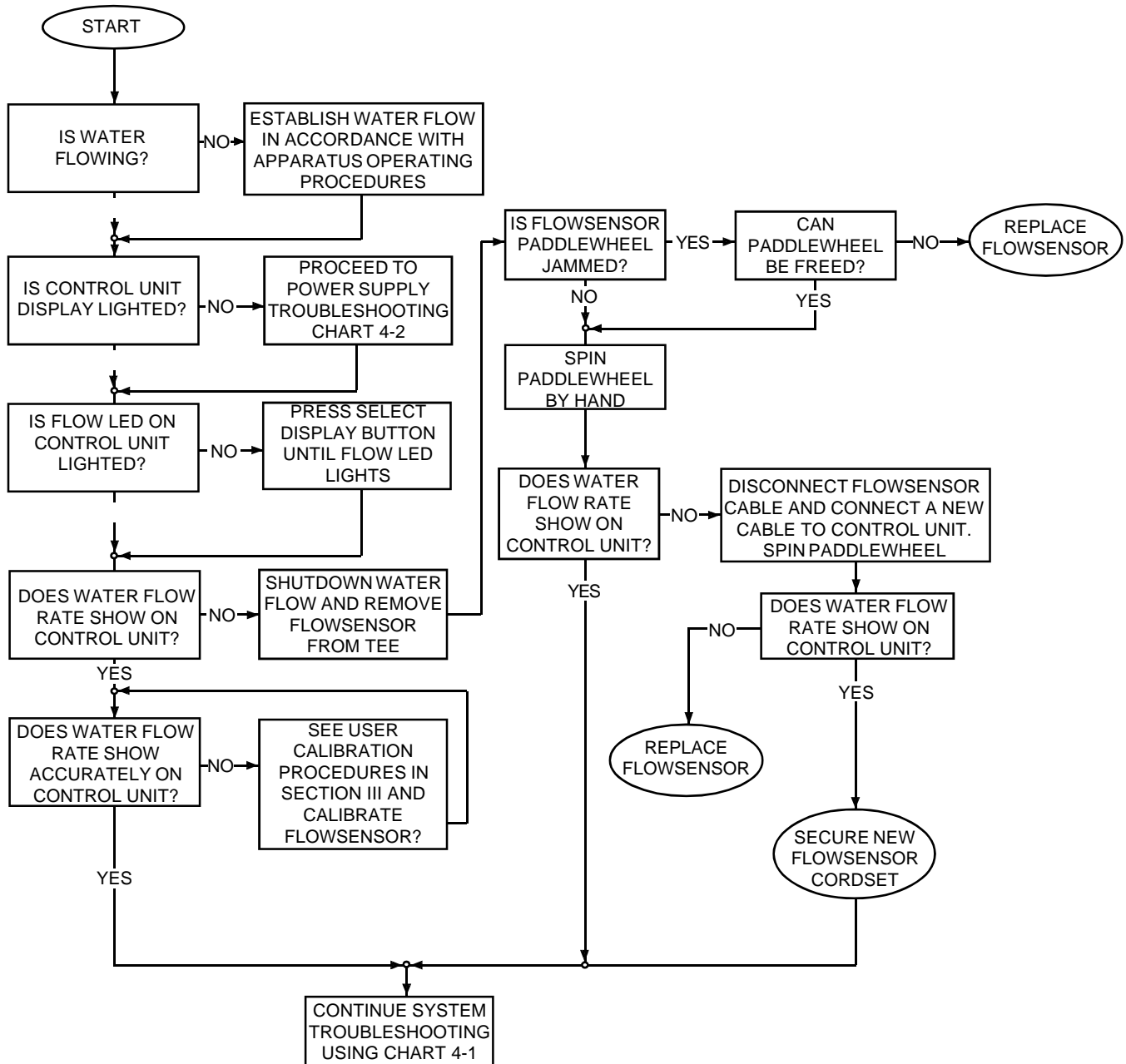
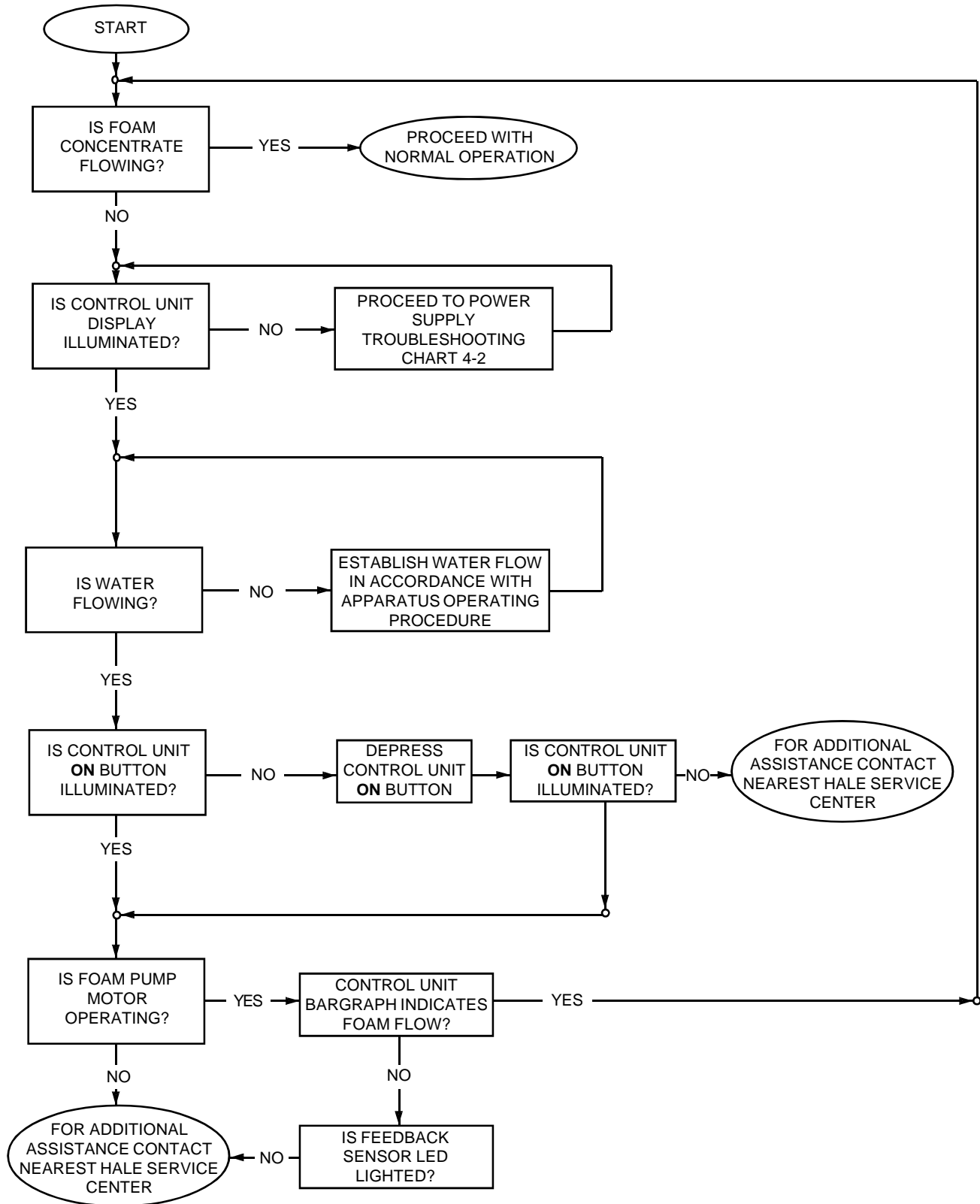

Chart 4-4. Foam Pump Troubleshooting



PARTS IDENTIFICATION

FOAM PUMP ASSEMBLY

REF	PART NUMBER	DESCRIPTION	QTY	UNIT
	501-3110-15-0	(MODEL 3.0) FM 3.0 PUMP ASSY (12 VOLT DC MOTOR)		
	501-3110-24-0	(MODEL 3.0) FM 3.0 PUMP ASSY (24 VOLT DC MOTOR)		
	501-3120-15-0	(MODEL 3.3) FM 3.3 PUMP ASSY (12 VOLT DC MOTOR)		
	501-3120-24-0	(MODEL 3.3) FM 3.3 PUMP ASSY (24 VOLT DC MOTOR)		
	501-3130-15-0	(MODEL 5.0) FM 5.0 PUMP ASSY (12 VOLT DC MOTOR)		
	501-3130-24-0	(MODEL 5.0) FM 5.0 PUMP ASSY (24 VOLT DC MOTOR)		
1	501-3110-00-0	FM3.0 GEAR PUMP ASSY (FM 3.0, FM 3.3)	1	EA
	501-3130-00-0	FM5.0 GEAR PUMP ASSY (FM5.0)	1	EA
2	013-0740-00-0	TERMINAL BOOT (BLACK)	1	EA
3	013-0740-05-0	TERMINAL BOOT (RED)	1	EA
4	200-2700-00-0	CABLE ADAPTER ASSEMBLY	1	EA
5	017-0680-00-0	DRIVE KEY	1	EA
6	018-1406-02-0	SCREW 5/16-18 X 3/4 PLD	4	EA
7	018-1612-17-0	SCREW-3/8-16 X 1-1/4	4	EA
8	045-0770-00-0	ELECTRIC MOTOR (12 VDC)	1	EA
	045-0770-01-0	ELECTRIC MOTOR (24 VDC)	1	EA
9	097-0140-02-0	WASHER-3/8 300 SER STNLS LOCK	4	EA
10	097-0310-00-0	WASHER-1/4 EXT TOOTH TYPE "A"	4	EA
11	097-0560-02-0	WASHER-5/16 300 SER SST LOCK	4	EA
12	097-0810-01-0	WASHER-5/16 ZINC PL STL FLAT	4	EA
13	097-1971-00-0	5 MM SEAL WASHER	1	EA
14	110-1200-02-0	NUT-1/4-20 ZINC PLATED STEEL	4	EA
15		NUT-5 MM X 0.5 PITCH SST (INCLUDED WITH ITEM 16)	1	EA
16	200-2481-00-0	SPEED SENSOR- 5MM (POWERED)	1	EA
17	200-2501-00-0	DISTRIBUTION BOX (FM 5.0, FM 3.3)	1	EA
	200-2501-01-0	DISTRIBUTION BOX (FM 3.0)	1	EA
18	538-1620-00-0	RELIEF VALVE KIT		
19	018-9610-00-0	ADJUSTING SCREW	1	EA
20	042-0680-00-0	RELIEF VALVE SPRING	1	EA
21	073-0220-00-0	RELIEF VALVE PISTON	1	EA
22	097-1980-00-0	SEALING WASHER	2	EA
23	110-2701-06-0	NUT-3/4-16 300 SER SST JAM	1	EA
24	110-2703-06-0	NUT-3/4-16 300 SER STNLS ACORN	1	EA
25	513-0350-00-0	BRACKET ASSEMBLY	1	EA
26	013-2050-00-0	GROUND STRAP ASSY	1	EA
27	097-2110-00-0	FLAT WASHER- 3/8 BRASS	4	EA
28	110-1600-08-0	NUT-3/8-16 UNC BRASS	2	EA
29	546-1780-00-0	CONNECTOR KIT (NOT SHOWN)	1	EA
30	013-2020-05-0	FOAMMASTER 6-PIN CABLE ASSY 16.41 FT(5 M) LG	1	EA
	013-2020-01-0	FOAMMASTER 6-PIN CABLE ASSY 3.28 FT (1 M) LG	1	EA
	013-2020-02-0	FOAMMASTER 6-PIN CABLE ASSY 6.56 FT (2 M) LG	1	EA
	013-2020-04-0	FOAMMASTER 6-PIN CABLE ASSY 13.12 FT (4 M) LG	1	EA
	013-2020-06-0	FOAMMASTER 6-PIN CABLE ASSY 19.69 FT (6 M) LG	1	EA

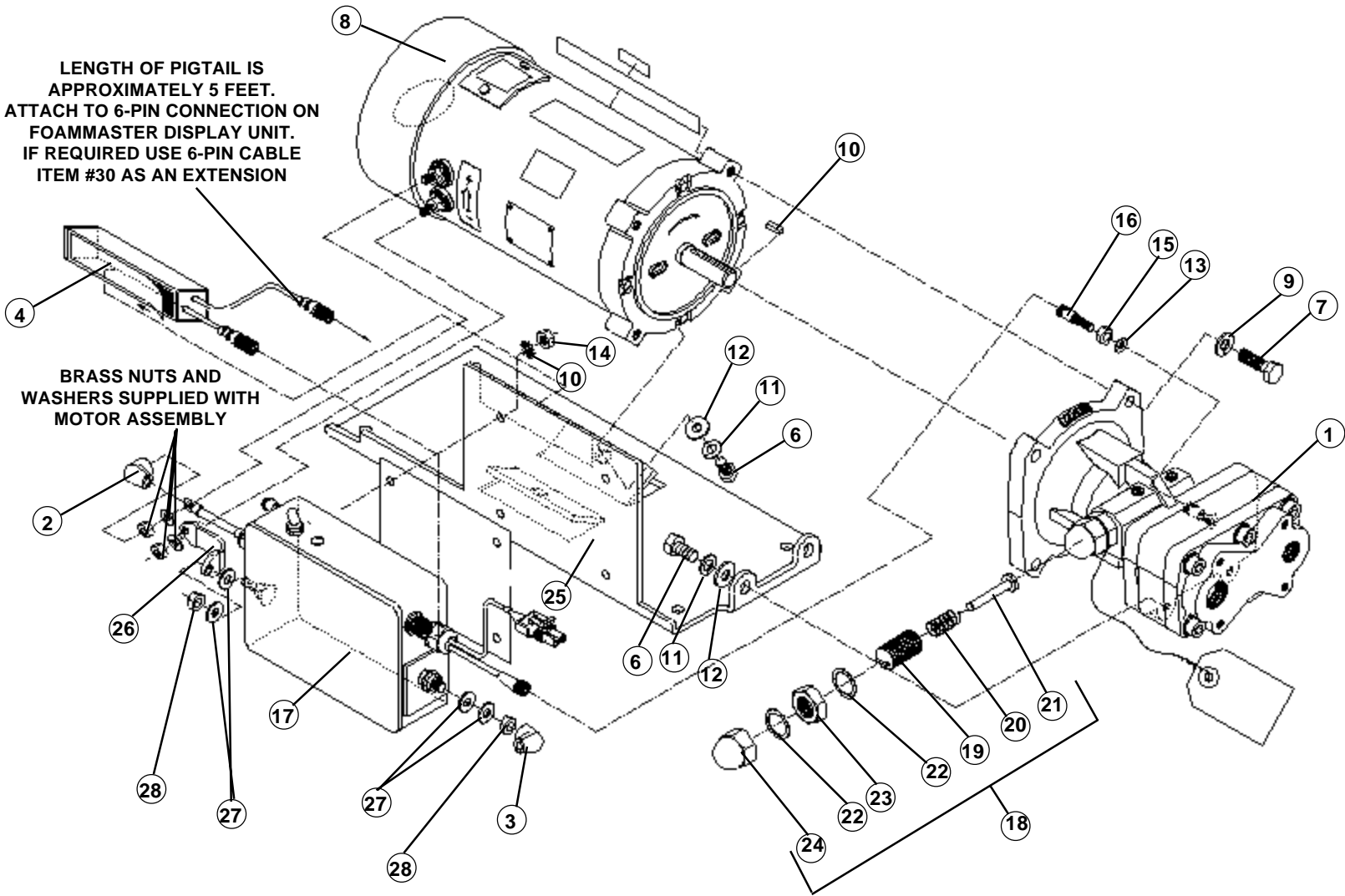

ADDITIONAL FOAMMASTER SYSTEM COMPONENTS

REF	PART NUMBER	DESCRIPTION	QTY	UNIT
1	038-1790-00-0	CHECK VALVE INJECTOR	1	EA
2	101-1630-04-0	FOAM MASTER NAMEPLATE	1	EA
3	101-1630-12-0	FOAM MASTER SYSTEM DIAGRAM NAMEPLATE (SINGLE TANK)	1	EA
4	168-0380-01-0	CONTROL UNIT	1	EA
5	110-1703-06-0	NUT	1	EA
6	012-1440-00-0	TEE HANDLE	1	EA
7	012-0450-00-0	HANDLE COVER	2	EA
8	018-1003-43-0	SCREW #10-24 X 3/8 IN LG	2	EA
9	101-1630-01-0	BYPASS PLACARD	1	EA
10	038-1810-00-0	BYPASS VALVE	1	EA
11	082-0408-02-0	1/2 INCH NPT CLOSE NIPPLE (BRASS)	1	EA

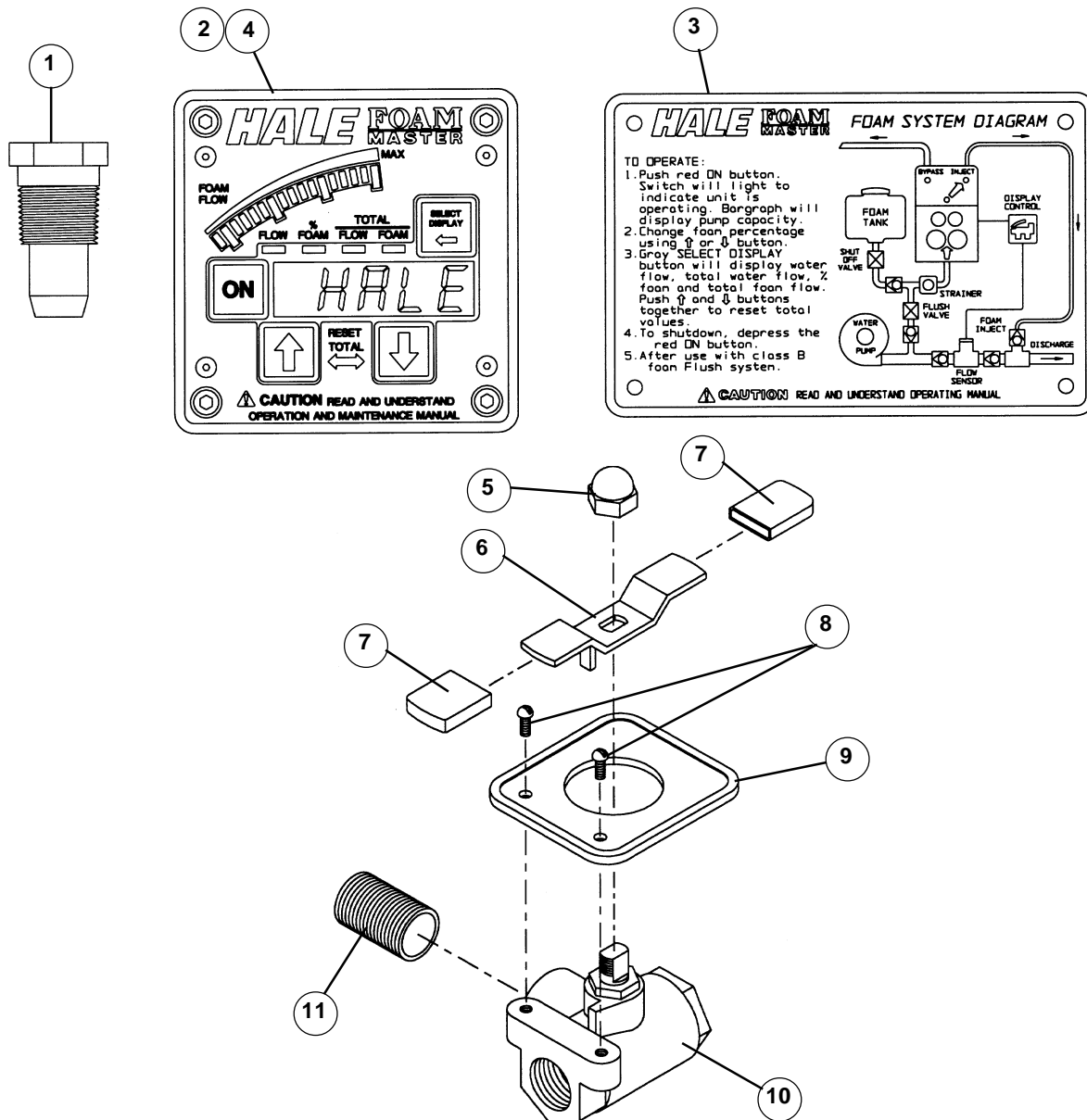

FOAMMASTER FLOWSENSOR

REF	PART NUMBER	DESCRIPTION	QTY	UNIT
	538-1600-15-0	HPF15 NPT FLOWSENSOR ASSY (1-1/2 INCH NPT)		
	538-1600-16-0	HPF15 ISO FLOWSENSOR ASSY (1-1/2 INCH ISO)		
	538-1600-20-0	HPF20 NPT FLOWSENSOR ASSY (2 INCH NPT)		
	538-1600-21-0	HPF20 ISO FLOWSENSOR ASSY (2 INCH ISO)		
	538-1600-25-0	HPF25 NPT FLOWSENSOR ASSY (2-1/2 INCH NPT)		
	538-1600-26-0	HPF25 ISO FLOWSENSOR ASSY (2-1/2 INCH ISO)		
	538-1600-30-0	HPF30 NPT FLOWSENSOR ASSY (3 INCH NPT)		
	538-1600-31-0	HPF30 ISO FLOWSENSOR ASSY (3 INCH ISO)		
	538-1600-40-0	HPF40 NPT FLOWSENSOR ASSY (4 INCH NPT)		
	538-1600-41-0	HPF40 ISO FLOWSENSOR ASSY (4 INCH ISO)		
1	007-2021-00-0	HPF15 NPT FLOWSENSOR TEE	1	EA
	007-2021-10-0	HPF15 ISO FLOWSENSOR TEE	1	EA
	007-2021-01-0	HPF20 NPT FLOWSENSOR TEE	1	EA
	007-2021-11-0	HPF20 ISO FLOWSENSOR TEE	1	EA
	007-2021-02-0	HPF25 NPT FLOWSENSOR TEE	1	EA
	007-2021-12-0	HPF25 ISO FLOWSENSOR TEE	1	EA
	007-2021-03-0	HPF30 NPT FLOWSENSOR TEE	1	EA
	007-2021-13-0	HPF30 ISO FLOWSENSOR TEE	1	EA
	007-2021-04-0	HPF40 NPT FLOWSENSOR TEE	1	EA
	007-2021-14-0	HPF40 ISO FLOWSENSOR TEE	1	EA
2	008-0710-00-0	HPF 2-1/2 NS THD CAP	1	EA
3	013-1680-00-0	HPF GROUND TERMINAL	1	EA
4	013-2010-04-0	FOAMMASTER 4-PIN CABLE ASSY 13.12 FT (4 M) LG (STD)	1	EA
	013-2010-01-0	FOAMMASTER 4-PIN CABLE ASSY 3.28 FT (1 M) LG (OPT)	1	EA
	013-2010-02-0	FOAMMASTER 4-PIN CABLE ASSY 6.56 FT (2 M) LG (OPT)	1	EA
	013-2010-05-0	FOAMMASTER 4-PIN CABLE ASSY 16.41 FT (5 M) LG (OPT)	1	EA
	013-2010-06-0	FOAMMASTER 4-PIN CABLE ASSY 19.69 FT (6 M) LG (OPT)	1	EA
5	018-0602-44-0	SCREW-#6-32 X 1/4	1	EA
6	040-1270-07-0	O-RING	2	EA
7	064-6360-00-0	HPF LOCATING PIN	1	EA
8	101-1610-00-0	HPF CAUTION DECAL	1	EA
9	200-2491-00-0	HPF SENSOR ASSY	1	EA

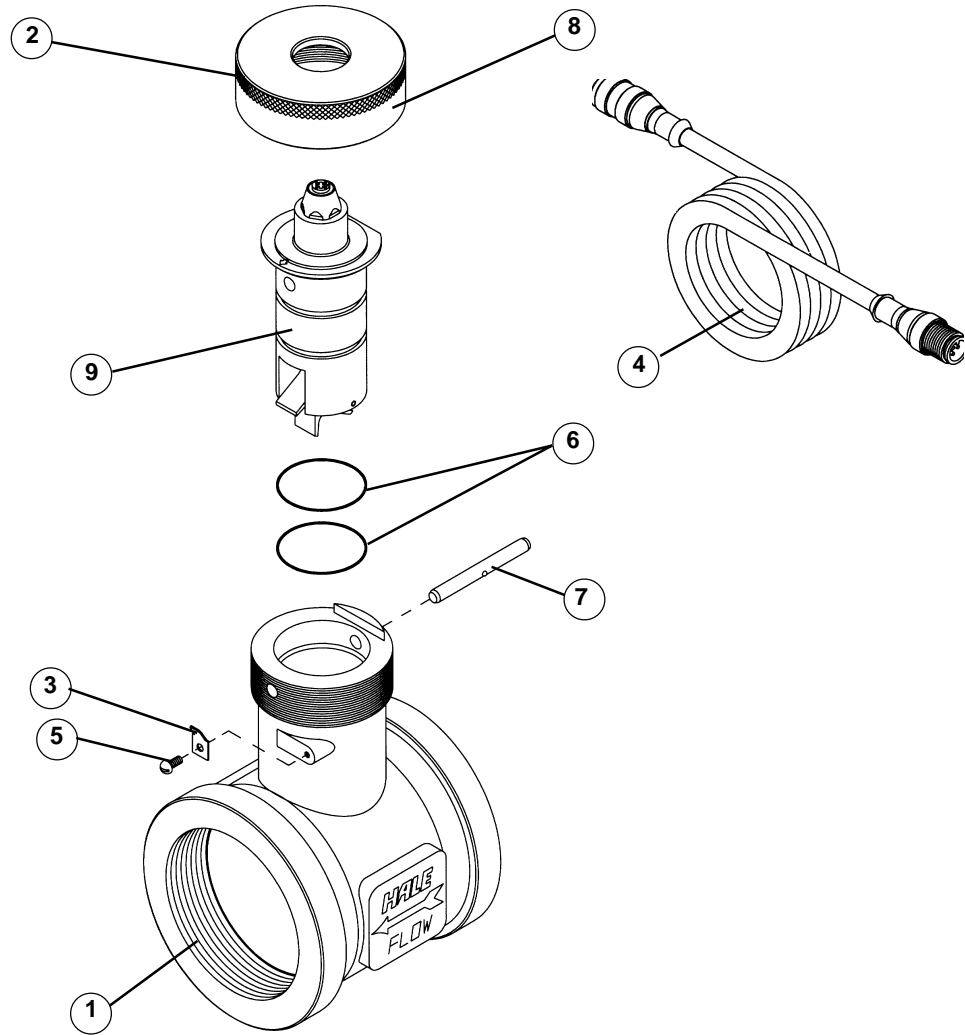

HALE FOAMMASTER AIR DUAL TANK VALVE (ADT)

REF	PART NUMBER	DESCRIPTION	QTY	UNIT
	538-1640-00-0	ADT VALVE ASSEMBLY (INCLUDES ITEMS MARKED * BELOW)		
*1	010-0660-00-0	INLET LINE STRAINER	1	EA
*2	012-1430-00-0	"PULL TO BYPASS" KNOB	1	EA
3	018-1222-12-0	SCREW ¼-20 X 2-¼ IN LG	1	EA
*4	018-1410-24-0	SCREW 5/16-18 X 1 IN LG	4	EA
5	038-1800-00-0	TOGGLE VALVE	1	EA
6	040-1180-00-0	40-3N118 SEAL RING	1	EA
7	040-1230-00-0	O-RING 123 BUNA	1	EA
8	082-0142-02-0	FITTING 1/8 NPT X ¼ TUBE PUSH CONN	2	EA
9	082-0143-02-0	ELBOW 1/8 NPT X ¼ TUBE PUSH CONN	2	EA
*10	082-0408-02-0	½ INCH NPT CLOSE NIPPLE (BRASS)	1	EA
*11	082-0414-02-0	½ INCH NPT SERVICE ELBOW (BRASS)	1	EA
*12	082-0521-05-0	¾ NPT X ¾ INCH HOSE NYLON ELBOW (NOT SHOWN)	1	EA
*13	082-0545-05-0	¾ NPT X 1 INCH HOSE NYLON ELBOW (NOT SHOWN)	1	EA
14	159-0760-00-0	SPACER	1	EA
15	200-0540-00-0	LIGHT ASSEMBLY (GREEN)	1	EA
16	200-0540-10-0	LIGHT ASSEMBLY (RED)	1	EA
17	200-1280-00-0	A-B INTERLOCK ASSEMBLY	1	EA
*18	200-2450-00-0	SWITCH	2	EA
19	101-1630-00-0	ADT NAMEPLATE	1	EA
20	101-1630-07-0	FOAM MASTER SYSTEM DIAGRAM NAMEPLATE (DUAL TANK)	1	EA
21	513-0300-00-0	ADT WIRING HARNESS	1	EA
22	538-1610-00-0	ADT SELECTOR PANEL ASSEMBLY	1	EA
23	538-1640-01-0	ADT VALVE ASSEMBLY	1	EA
24	507-0380-00-0	AIR HARNESS ASSEMBLY (OPTIONAL)	1	EA

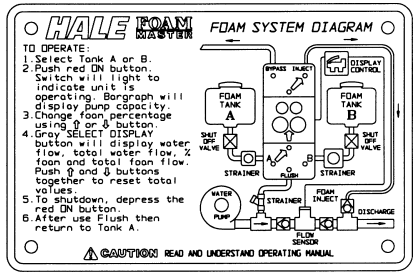
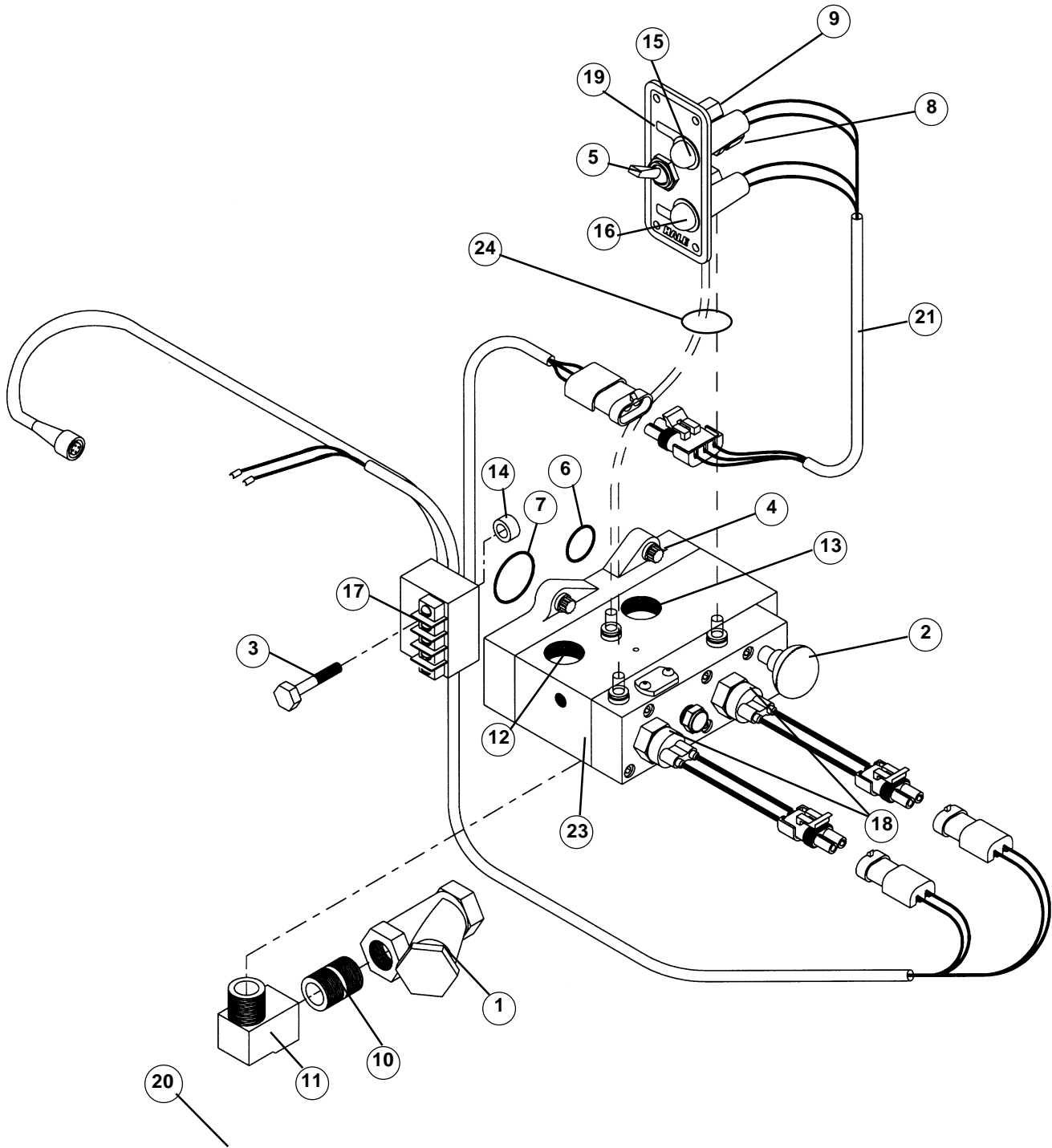

WARRANTY

LIMITED WARRANTY

EXPRESS WARRANTY. Hale Products Inc. ("Hale") hereby warrants to the original buyer that products manufactured by it are free of defects in material and workmanship for one (1) year. The "Warranty Period" commences on the date the original buyer takes delivery of the product from the manufacturer.

LIMITATIONS. HALE'S obligation is expressly conditioned on the Product being.

- Subjected to nominal use and service;
- Properly maintained in accordance with HALE'S Instruction Manual as to recommended services and procedures;
- Not damaged due to abuse, misuse, negligence or accidental causes;
- Not altered, modified, serviced (non-routine) or repaired other than by an Authorized Service Facility;
- Manufactured per design and specifications submitted by the original Buyer.

THE ABOVE EXPRESS LIMITED WARRANTY IS EXCLUSIVE. NO OTHER EXPRESS WARRANTIES ARE MADE. SPECIFICALLY EXCLUDED ARE ANY IMPLIED WARRANTIES, INCLUDING WITHOUT LIMITATIONS, THE IMPLIED WARRANTIES OF MERCHANTABILITY OR FITNESS FOR A PARTICULAR PURPOSE OR USE; QUALITY; COURSE OF DEALING; USAGE OF TRADE; OR PATENT INFRINGEMENT FOR A PRODUCT MANUFACTURED TO ORIGINAL BUYER'S DESIGN AND SPECIFICATIONS.

EXCLUSIVE REMEDIES. If Buyer promptly notifies HALE upon discovery of any such defect (within the Warranty Period), the following terms shall apply:

- Any notice to HALE must be in writing, identifying the Product (or component) claimed defective and circumstances surrounding its failure;
- HALE reserves the right to physically inspect the Product and require Buyer to return same to HALE'S plant or other Authorized Service Facility;
- In such event, Buyer must notify HALE for a Returned Goods Authorization number and Buyer must return the Product F.O.B. within (30) days thereof;
- If determined defective, HALE shall, at its option, repair or replace the Product, or refund the purchase price (less allowance for depreciation),
- Absent proper notice *within* the Warranty Period, HALE shall have no further liability or obligation to Buyer therefore.

THE REMEDIES PROVIDED ARE THE SOLE AND EXCLUSIVE REMEDIES AVAILABLE. IN NO EVENT SHALL HALE BE LIABLE FOR INCIDENTAL OR CONSEQUENTIAL DAMAGES INCLUDING, WITHOUT LIMITATION, LOSS OF LIFE; PERSONAL INJURY; DAMAGE TO REAL OR PERSONAL PROPERTY DUE TO WATER OR FIRE; TRADE OR OTHER COMMERCIAL LOSSES ARISING, DIRECTLY OR INDIRECTLY, OUT OF PRODUCT FAILURE.