

HALE **FOAM** **MASTER** **V-Series**

Venturi Based Balanced Pressure Foam Proportioning System

Installation and Operation Manual



	Foam Concentrate Flow	Maximum Operating Pressure
Model 2.5V	2.5 GPM (9.5 LPM)	150 PSI (10 BAR)
Model 1.0V	1.0 GPM (3.8 LPM)	250 PSI (17 BAR)

HALE Products, Inc.
700 Spring Mill Ave.
Conshohocken, PA 19428 U.S.A.
Ph: (610) 825-6300
Fax: (610) 825-6440

<http://www.haleproducts.com>

ECO NO	REV	CHANGED FROM	BY	DATE	APVD	 HALE PRODUCTS, INC A Unit of IDEX Corporation Conshohocken, PA 19428 USA			
01-392	C	Update to new Format	PRW	11/7/2001	MAL				
						CHECKED BY:	PRW	11/17/2001	NOT TO BE REPRODUCED OR USED TO MAKE OTHER DRAWINGS OR MACHINERY

HALE **FOAM** **MASTER** **V-Series**

Venturi Based Balanced Pressure Foam Proportioning System

Table of Contents

Safety Information	3
System Description	7
System Configuration	8
Installation	10
Operation	18
Maintenance and Troubleshooting	20
Parts	22
Appendix I: FoamMaster V-Series Venturi Section	24
Appendix II: FoamMaster V-Series System Diagram	25

ECO NO	REV	CHANGED FROM	BY	DATE	APVD					
01-392	C	Update to new Format	PRW	11/7/2001	MAL		HALE PRODUCTS, INC A Unit of IDEX Corporation Conshohocken, PA 19428 USA			
							DRAWN BY:	PRW	ISSUE DATE:	COPYRIGHT ©
							CHECKED BY:	PRW	11/7/2001	NOT TO BE REPRODUCED OR USED TO MAKE OTHER DRAWINGS OR MACHINERY

HALE **FOAM** **MASTER** **V-Series**

Venturi Based Balanced Pressure Foam Proportioning System

Safety Information

Hale FoamMaster systems are designed to provide safe and reliable foam concentrate injection. Before installing or operating a FoamMaster system, read all safety precautions and follow the instructions carefully to ensure proper installation and personal safety.

WARNING

- Do not permanently remove or alter any guards or insulating devices. It is unsafe to operate the system with these guards removed.
- To prevent electrical shock, always disconnect the primary power source before servicing any part of the FoamMaster system.
- All electrical systems have the potential to create sparks while being serviced. Before working, take care to remove anything explosive or hazardous from the environment.
- To prevent system damage or electrical shock, the main power supply wire will be the last connection made to the FoamMaster wiring harness.
- Before servicing any components, it is important to depressurize the system and drain it of all concentrate and water.
- Be careful of rotating driveline components when working on the FoamMaster system, as they can be dangerous.

ECO NO	REV	CHANGED FROM	BY	DATE	APVD	 HALE PRODUCTS, INC A Unit of IDEX Corporation Conshohocken, PA 19428 USA					
01-392	C	Update to new Format	PRW	11/7/2001	MAL						
						DRAWN BY:		PRW	ISSUE DATE:		COPYRIGHT © NOT TO BE REPRODUCED OR USED TO MAKE OTHER DRAWINGS OR MACHINERY
						CHECKED BY:		PRW	11/7/2001		

HALE FOAM MASTER V-Series

Venturi Based Balanced Pressure Foam Proportioning System

CAUTION

- Foam tank low-level sensors should be utilized as extra protection to prevent the system from running dry. Damage could occur to the pump if these sensors are not used.
- Do not operate the system at pressures higher than those listed below:

	Maximum Pressure	
	FM 1.0V	FM 2.5V
Operation	250 PSI (17 BAR)	150 PSI (10 BAR)
Hydrotest	400 PSI (28 BAR)	400 PSI (28 BAR)
Priming	100 PSI (7 BAR)	100 PSI (7 BAR)

- Throughout the entire piping system, only use pipe, hose, and fittings that are rated at or above the maximum operating pressure of the water pump.
- FoamMaster systems are designed for use on negative ground, 12 or 24-volt direct current (DC) electrical systems. The operating voltage is indicated in the model name. For example, model 2.5V-12 is a 12-volt system.
- Make sure the foam tank and concentrate suction hoses are clean before making the final connection to foam pump. If necessary, flush the tank and hoses.
- Before connecting a cord set, inspect the seal washer in the female connector. If it is missing or damaged, water can enter the connector causing the pins and terminals to corrode.
- Always disconnect the power cable, ground straps, electrical wires and control cables from the control unit or other FoamMaster equipment before performing any electric arc welding. Failure to do so may result in a power surge capable of doing irreparable damage to the unit.
- *Do not* connect the main power lead to any small leads that supply another device, such as a light bar or siren. The FoamMaster model 1.0V requires a current between 15 and 25 amps, while the 2.5V model needs to be supplied with 30 to 40 amps. Make sure to use the correct gauge of wire.
- Ensure that the system is drained of water when temperatures below freezing are expected. This will prevent damage to wet components.

ECO NO	REV	CHANGED FROM	BY	DATE	APVD		HALE PRODUCTS, INC		
01-392	C	Update to new Format	PRW	11/7/2001	MAL		A Unit of IDEX Corporation Conshohocken, PA 19428 USA		
						DRAWN BY:	PRW	ISSUE DATE:	COPYRIGHT ©
						CHECKED BY:	PRW	11/7/2001	NOT TO BE REPRODUCED OR USED TO MAKE OTHER DRAWINGS OR MACHINERY

HALE FOAM MASTER V-Series

Venturi Based Balanced Pressure Foam Proportioning System

NOTES

- After each use, check for weak or worn hoses. Ensure that all connections and fittings are tight and secure.
- The source of power for the unit must be a negative ground DC system with the correct input voltage and minimum reserve current required to drive the FoamMaster system.
- When determining the location of FoamMaster components, keep in mind piping runs, cable routing, and any interferences that will hinder proper system performance.
- Prevent corrosion of power and ground connections by sealing them with silicone sealant.
- Always position the check valve/proportioner section in a manner that will allow draining. This will avoid sediment deposits or the formation of an ice plug.
- The cord sets provided with each Hale FoamMaster system are indexed so they only mate with the correct receptacle and can only be inserted in one direction. When making cord set connections, *do not* force any mismatched connections as damage can result from improper system operation.
- Make sure the connections to the power source are properly insulated and sealed by using an adhesive filled heat shrink tubing where applicable.
- The system can only perform when the electrical connections are sound. Verify all electrical connections prior to start up.
- Each FoamMaster system is tested at the factory using the wiring harness provided. Improper handling and forcing connections can damage these cables, compromising the performance of the system.
- Use mounting hardware that is compatible with every foam concentrate that will be used in the system. Use washers, lock-washers and cap screws made of brass or 300 series stainless steel.
- Always secure the foam percentage cable along its full length. An unsecured cable will move during operation, altering the control settings. It is recommended that wire ties, hold-downs, or similar clamping devices be used every 12” to prevent sagging. Make sure the connections are tight enough to hold the cable in place, but not so tight that they deform the cable.
- To avoid problems with the foam percentage cable, minimize the number of bends used to install the system. Never use sharp bends that will kink the inner wire.

ECO NO	REV	CHANGED FROM	BY	DATE	APVD	 HALE PRODUCTS, INC A Unit of IDEX Corporation Conshohocken, PA 19428 USA					
01-392	C	Update to new Format	PRW	11/7/2001	MAL						
						DRAWN BY: PRW		ISSUE DATE: 111/7/2001		COPYRIGHT © NOT TO BE REPRODUCED OR USED TO MAKE OTHER DRAWINGS OR MACHINERY	
						CHECKED BY: PRW					

HALE **FOAM** **MASTER** **V-Series**

Venturi Based Balanced Pressure Foam Proportioning System

- The safety relief valve is preset at the factory at 290/300 psi on 1.0V models and 160/165 psi on 2.5V models.
- Model numbers 1.0V-12M, 1.0V-24M, 2.5V-12M, and 2.5V-24M use 2½” female BSP (ISO228/1-G2½) threaded connections on the venturi tube. All others have 2½” female NPT. Every model has 3” Victaulic® connections as well.

Model	2.5” Female NPT	2.5” Female BSP (ISO228/1-G2½)	3” Victaulic®
FoamMaster 1.0V-12	✓		✓
FoamMaster 1.0V-12M		✓	✓
FoamMaster 1.0V-24M		✓	✓
FoamMaster 2.5V-12	✓		✓
FoamMaster 2.5V-12M		✓	✓
FoamMaster 2.5V-24M		✓	✓

ECO NO	REV	CHANGED FROM	BY	DATE	APVD		HALE PRODUCTS, INC		
01-392	C	Update to new Format	PRW	11/7/2001	MAL		A Unit of IDEX Corporation Conshohocken, PA 19428 USA		
						DRAWN BY:	PRW	ISSUE DATE:	COPYRIGHT ©
						CHECKED BY:	PRW	11/17/2001	NOT TO BE REPRODUCED OR USED TO MAKE OTHER DRAWINGS OR MACHINERY

HALE **FOAM** **MASTER** **V-Series**

Venturi Based Balanced Pressure Foam Proportioning System

System Description

The FoamMaster V-Series consists of three main components: a foam pump/motor assembly, control panel, and venturi section. These three parts work together to provide a reliable foam proportioning system. The control panel allows the operator to turn the system on, adjust the foam injection percentage, and prime the foam lines.

The FoamMaster system works by creating a pressure drop between the water and the foaming agent. The water stream passes through a low-pressure drop venturi creating a slight pressure drop in the throat of the venturi. This draws foaming agent from a diaphragm housing and then into the venturi at a rate proportional to the water flow. The foam pump cycles on and off as necessary to provide the diaphragm housing with a supply of foam concentrate. A metering valve controls the amount of concentrate drawn into the venturi. The position of this valve is adjusted through a cable connected to a lever on the control panel. Once the percentage is set on the panel, the flow rate of the foam concentrate automatically changes to maintain proportionality with the water flow rate.

The FoamMaster system turns on when the control knob is moved away from the “off” position, illuminating a bright green LED. The operator may prime the system with foam concentrate directly from the control panel by moving the knob to the “prime” position. This is only required when introducing a fresh supply of foam concentrate into the system.

The venturi section of the system is provided with female pipe thread connections as well as 3” Victaulic® grooves to make installation versatile and easy. The venturi also has a built-in check valve feature to prevent the water tank from becoming contaminated with foam. A separate user-supplied check valve should be installed between the venturi and the fire pump to further prevent contamination.

FoamMaster foam proportioning systems are completely engineered and factory matched to provide reliable, consistent foam concentrate injection for Class A foam operations. FoamMaster V-Series systems directly inject between 0.1% and 1.0% foam concentrate into the water discharge stream. The foam solution is then fed through the apparatus discharge piping into a standard fog nozzle, air aspirated nozzle, or CAFS equipment. A properly configured and installed FoamMaster system with components recommended by Hale virtually eliminates the possibility of foam contamination in the booster tank, fire pump, or relief valve.

ECO NO	REV	CHANGED FROM	BY	DATE	APVD	 HALE PRODUCTS, INC A Unit of IDEX Corporation Conshohocken, PA 19428 USA			
01-392	C	Update to new Format	PRW	11/7/2001	MAL				
						DRAWN BY:	PRW	ISSUE DATE:	COPYRIGHT ©
						CHECKED BY:	PRW	11/17/2001	NOT TO BE REPRODUCED OR USED TO MAKE OTHER DRAWINGS OR MACHINERY

HALE **FOAM** **MASTER** **V-Series**

Venturi Based Balanced Pressure Foam Proportioning System

System Configuration

Hale FoamMaster System Models 1.0V or 2.5V include:

- Foam Pump / Motor Assembly
- Control Panel with Wiring Harness
- Venturi Section
- Control Cable
- All Necessary Fittings and Tubing

Foam Pump/Motor Assembly

Shown with pre-assembled safety relief valve, filter, and all fittings necessary for installation.

NOTE: Hose and tubing not connected for shipment.



ECO NO	REV	CHANGED FROM	BY	DATE	APVD	 HALE PRODUCTS, INC A Unit of IDEX Corporation Conshohocken, PA 19428 USA			
01-392	C	Update to new Format	PRW	11/7/2001	MAL				

HALE FOAM MASTER V-Series

Venturi Based Balanced Pressure Foam Proportioning System

Control Panel



Venturi Section



ECO NO	REV	CHANGED FROM	BY	DATE	APVD	 HALE PRODUCTS, INC A Unit of IDEX Corporation Conshohocken, PA 19428 USA					
01-392	C	Update to new Format	PRW	11/7/2001	MAL						
						DRAWN BY: PRW		ISSUE DATE: 11/7/2001		COPYRIGHT © NOT TO BE REPRODUCED OR USED TO MAKE OTHER DRAWINGS OR MACHINERY	
						CHECKED BY: PRW					

HALE FOAM MASTER V-Series

Venturi Based Balanced Pressure Foam Proportioning System

Installation

The diagrams included at the end of this manual illustrate proper installation guidelines and dimensions for the FoamMaster V-Series foam proportioning systems. Plate number EQ725 is a component part breakdown of the venturi section with dimensional information. Plate number EQ727 is a system diagram with dimensional information for the control panel.

There are 14 easy steps to follow when installing a FoamMaster V-Series system. After completing the installation, double-check that all the wires, tubing, lines, fittings, and connections are secure before operating the system.

Step 1

Mount Pump

Using the supplied grommets, mount the pump using the four mounting flange holes.

Pump must be mounted in horizontal position

Ensure that there is enough room below the strainer for clearance and removal.



ECO NO	REV	CHANGED FROM	BY	DATE	APVD	 HALE PRODUCTS, INC A Unit of IDEX Corporation Conshohocken, PA 19428 USA					
01-392	C	Update to new Format	PRW	11/7/2001	MAL						
						DRAWN BY: PRW		ISSUE DATE: 11/7/2001		COPYRIGHT © NOT TO BE REPRODUCED OR USED TO MAKE OTHER DRAWINGS OR MACHINERY	
						CHECKED BY: PRW					

HALE FOAM MASTER V-Series

Venturi Based Balanced Pressure Foam Proportioning System

Step 4

Route and Cut Control Cable

Choose a route for the control cable that minimizes sharp bends and does not cause any kinks. The cable may be shortened to remove any excess. Cut the cable so that at least six inches of inner wire extends from the outer conduit. Using the fittings provided, insert the control cable into position in the venturi section and guide the inner wire into the brass valve stem.



Step 5

Tighten Fitting

Tighten the nut on the fitting with pliers or a wrench.



ECO NO	REV	CHANGED FROM	BY	DATE	APVD	 HALE PRODUCTS, INC A Unit of IDEX Corporation Conshohocken, PA 19428 USA			
01-392	C	Update to new Format	PRW	11/7/2001	MAL				
						CHECKED BY:	PRW	11/17/2001	NOT TO BE REPRODUCED OR USED TO MAKE OTHER DRAWINGS OR MACHINERY

HALE FOAM MASTER V-Series

Venturi Based Balanced Pressure Foam Proportioning System

Step 6

Attach Control Cable

Insert the inner wire of the control cable into the end hole of the brass valve stem as far as possible and then tighten the socket head cap screw with a hex key wrench to secure it in place.



Step 7

Attach Control Cable to Control Panel

Insert the panel end of the control cable into the fitting on the control panel. Guide the inner wire through the swivel nut on the lever. Tighten the fitting nut. Do not tighten the swivel nut screw at this time.

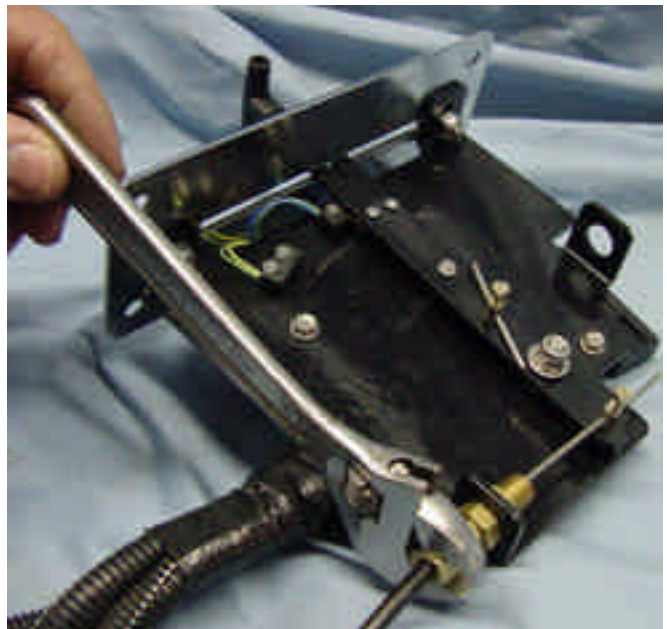

ECO NO	REV	CHANGED FROM	BY	DATE	APVD	 HALE PRODUCTS, INC A Unit of IDEX Corporation Conshohocken, PA 19428 USA			
01-392	C	Update to new Format	PRW	11/7/2001	MAL				
						CHECKED BY:	PRW	11/7/2001	NOT TO BE REPRODUCED OR USED TO MAKE OTHER DRAWINGS OR MACHINERY

HALE FOAM MASTER V-Series

Venturi Based Balanced Pressure Foam Proportioning System

Step 8

Mount Control Cable

Secure the control cable in a fixed position on the vehicle frame (or wherever the unit is mounted) for its entire length using wire ties, or other suitable clamping means. Pull the brass valve stem until it hits the brass stop in the housing by gently grasping the opposite end of the inner wire with pliers and applying a small amount of force.



Step 9

Adjust Control Panel

Move the knob on the control panel to the prime position while allowing the inner wire to slide within the swivel nut. Tighten the swivel nut screw with a screwdriver. This procedure automatically calibrates the system. Move the control knob back and forth slowly several times to check for proper motion.

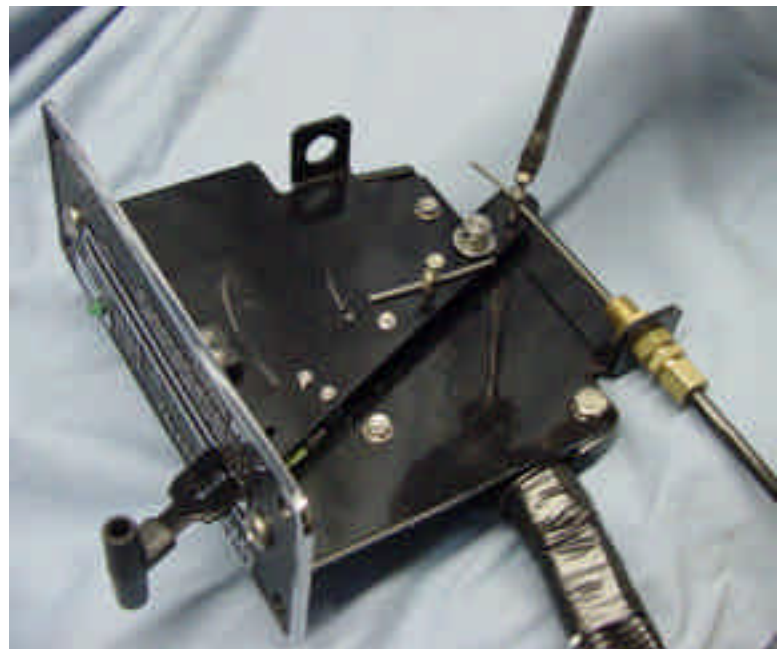

ECO NO	REV	CHANGED FROM	BY	DATE	APVD	 HALE PRODUCTS, INC A Unit of IDEX Corporation Conshohocken, PA 19428 USA			
01-392	C	Update to new Format	PRW	11/7/2001	MAL				
						DRAWN BY:	PRW	ISSUE DATE:	COPYRIGHT ©
						CHECKED BY:	PRW	11/17/2001	NOT TO BE REPRODUCED OR USED TO MAKE OTHER DRAWINGS OR MACHINERY

HALE FOAM MASTER V-Series

Venturi Based Balanced Pressure Foam Proportioning System

Step 10

Attach Inlet Hose

Connect the supplied inlet hose between the foam tank and the inlet of the foam pump assembly. Secure both ends with hose clamps.



Step 11

Connect Foam Supply to Pump

Connect the provided 3/8" OD nylon foam supply tubing to the outlet of the foam pump and then tighten the fitting nut.



ECO NO	REV	CHANGED FROM	BY	DATE	APVD	 HALE PRODUCTS, INC A Unit of IDEX Corporation Conshohocken, PA 19428 USA				
01-392	C	Update to new Format	PRW	11/7/2001	MAL					DRAWN BY:
						CHECKED BY:		PRW	11/7/2001	NOT TO BE REPRODUCED OR USED TO MAKE OTHER DRAWINGS OR MACHINERY

HALE FOAM MASTER V-Series

Venturi Based Balanced Pressure Foam Proportioning System

Step 12

Connect Foam Supply and Prime Return Lines to Venturi

Trim any excess length from the foam supply tubing. Insert the end into the venturi section foam supply fitting and tighten the fitting nut. Secure the tubing in place using wire ties or other suitable clamping means.

Connect the provided foam prime return line to the top of the foam tank or a collection container. Next, connect the other end to the prime fitting on the venturi section and secure it with a hose clamp.



Step 13

Connect Wiring Harness to Pump and Venturi

Route the wiring harness pigtails from the panel to the foam pump and venturi section. Secure them in place and push the connectors together. Note: The ends are keyed and will only plug into the correct mating connector. If the connectors won't fit together with minimal force, do not force the connection. Instead, try joining a different combination.



ECO NO	REV	CHANGED FROM	BY	DATE	APVD		HALE PRODUCTS, INC		
01-392	C	Update to new Format	PRW	11/7/2001	MAL		A Unit of IDEX Corporation Conshohocken, PA 19428 USA		
						DRAWN BY:	PRW	ISSUE DATE:	COPYRIGHT ©
						CHECKED BY:	PRW	11/1/2001	NOT TO BE REPRODUCED OR USED TO MAKE OTHER DRAWINGS OR MACHINERY

HALE FOAM MASTER V-Series

Venturi Based Balanced Pressure Foam Proportioning System

Step 14

Connect to Power Source

Route the wiring harness power leads from the panel to a battery or other 12/24-volt DC power source, depending on your system. Secure the leads. The final step is to connect power to the unit. First connect the red wire to the positive (+) terminal, and then the black wire to the negative (-) terminal.



The installation is complete. Before operating the system, double-check that all the wires, tubing, lines, fittings, and connections are secure.

ECO NO	REV	CHANGED FROM	BY	DATE	APVD	 HALE PRODUCTS, INC A Unit of IDEX Corporation Conshohocken, PA 19428 USA			
01-392	C	Update to new Format	PRW	11/7/2001	MAL				
						CHECKED BY:	PRW	11/17/2001	NOT TO BE REPRODUCED OR USED TO MAKE OTHER DRAWINGS OR MACHINERY

HALE FOAM MASTER V-Series

Venturi Based Balanced Pressure Foam Proportioning System

Operation

Initial set-up:

1. Fill foam tank with foam concentrate.
2. Move the knob on the control panel to the “prime” position. The green LED will illuminate, indicating that the system is on. Hold it there until the system is primed, and then return it to the "off" position. To help determine when the system is primed, the FoamMaster V-Series is supplied with a transparent hose that allows visual indication of system status. The audible pitch of the foam pump will also change when the system is primed. Note: The system only has to be re-primed when the foam pump draws air into it. If the system is maintained wet, no priming is necessary. When drawing the foam concentrate from a pail, the system should be primed with each new bucket of foam.

Using your FoamMaster V-Series:

1. Once the main water pump is primed and stable operation is reached, move the knob on the control panel to the desired foam percentage. The green LED light will illuminate, indicating that the system is on. The knob may be re-adjusted to another percentage at any time. The system will maintain the foam injection percentage setting despite flow and pressure changes.
2. During operation, the foam pump will cycle on and off to maintain the supply of foam concentrate to the venturi section, where the concentrate is metered into the water stream at a steady, constant rate. This provides a uniform mixture of foam and water.
3. Move the control knob back to the off position when you wish to stop the flow of foam. The green LED light will go out, indicating that the system is off.
4. You may keep the system filled with Class A foam at all time. However, if you want to flush the system, just “prime” water as you would foam concentrate. A three-way valve is installed between the inlet of the foam pump, foam tank, and water source to provide fresh water for flushing. Just switch the valve to “water” and follow the priming instructions. Run water through the system for at least 15 seconds. Caution: The prime return hose connected to the venturi section should not be connected to the foam concentrate tank in this case. If a pail with a pick-up tube is the preferred method, just fill the pail with water and prime the FoamMaster for at least 15 seconds.
5. Always drain the system of all water to prevent damage from freezing.

ECO NO	REV	CHANGED FROM	BY	DATE	APVD	 HALE PRODUCTS, INC A Unit of IDEX Corporation Conshohocken, PA 19428 USA			
01-392	C	Update to new Format	PRW	11/7/2001	MAL				
						DRAWN BY:	PRW	ISSUE DATE:	COPYRIGHT ©
						CHECKED BY:	PRW	11/7/2001	NOT TO BE REPRODUCED OR USED TO MAKE OTHER DRAWINGS OR MACHINERY

HALE **FOAM** **MASTER** **V-Series**

Venturi Based Balanced Pressure Foam Proportioning System

The following are provided as a quick operation reference:

V-Series Quick Reference

- To prime FoamMaster system, move control to prime until foam is visible through transparent return hose.
- Once system is primed, move control to the desired foam injection percentage. This may be adjusted at any time.
- Move the control to OFF position to stop the flow of foam.
- An approved Class A foam may be left in the system. To flush the system, prime and operate with water until clear.

V-Series Quick Reference

- Read and Understand the Operation Manual
- Prime the FoamMaster system at less than 100 PSI (7 Bar) Pump Pressure
- Max Operation Pressure FM 2.5V 150 PSI (10 Bar)
FM 1.0V 250 PSI (17 Bar)
- Move the FoamMaster control to prime before selecting the desired foam injection percentage

ECO NO	REV	CHANGED FROM	BY	DATE	APVD		HALE PRODUCTS, INC		
01-392	C	Update to new Format	PRW	11/7/2001	MAL		A Unit of IDEX Corporation Conshohocken, PA 19428 USA		
						DRAWN BY:	PRW	ISSUE DATE:	COPYRIGHT ©
						CHECKED BY:	PRW	11/17/2001	NOT TO BE REPRODUCED OR USED TO MAKE OTHER DRAWINGS OR MACHINERY

HALE FOAM MASTER V-Series

Venturi Based Balanced Pressure Foam Proportioning System

Maintenance and Troubleshooting

Monthly:

- Inspect wiring, hoses, fittings, piping, connections, control cable, and tubing for tightness, corrosion, leaks, or damage.
- Remove and clean foam concentrate strainer. Flush as necessary.
- Lubricate the cam bearing of the foam pump by reaching into the gap in the top of the foam pump and applying bearing grease with a small brush.

Annually:

- Inspect check valve seals for wear or damage. Replace as necessary.

As Required:

- Clean out the area below the foam pump. It is normal to have a minute amount of seepage that may collect in the area below the foam pump. Clean out as necessary.

Warning:

If severe leakage is found in the venturi section, do not disassemble the diaphragm housing, as there are sensitive internal parts that may be scratched. Instead, replace the entire assembly. During reassembly, tighten all nuts and bolts to 15 ft-lbs in an "X" pattern to prevent the housing from mushrooming.

ECO NO	REV	CHANGED FROM	BY	DATE	APVD	 HALE PRODUCTS, INC A Unit of IDEX Corporation Conshohocken, PA 19428 USA			
01-392	C	Update to new Format	PRW	11/7/2001	MAL				
						DRAWN BY:	PRW	ISSUE DATE:	COPYRIGHT ©
						CHECKED BY:	PRW	11/17/2001	NOT TO BE REPRODUCED OR USED TO MAKE OTHER DRAWINGS OR MACHINERY

HALE FOAM MASTER V-Series

Venturi Based Balanced Pressure Foam Proportioning System

Fuse Location

The fuse is conveniently located just behind the control panel. To change the fuse, just un-plug the environmentally sealed holder and pull out the fuse. Replace it with a new blade style fuse and push the holder back together. The 2.5-V uses a 40-amp fuse and the 1.0-V uses a 20-amp fuse.



Parts

The following parts list provides the part numbers for all of the components used in the FoamMaster V-Series foam proportioning system.

Please record the model and serial number of your unit. This will ensure that you provide accurate information when placing an order with a Hale customer service representative. The ID tag is located on the side of the venturi section as shown in the accompanying picture.



MODEL: _____ SERIAL # _____

ECO NO	REV	CHANGED FROM	BY	DATE	APVD	 HALE PRODUCTS, INC A Unit of IDEX Corporation Conshohocken, PA 19428 USA					
01-392	C	Update to new Format	PRW	11/7/2001	MAL						
						DRAWN BY: PRW		ISSUE DATE: 11/7/2001		COPYRIGHT © NOT TO BE REPRODUCED OR USED TO MAKE OTHER DRAWINGS OR MACHINERY	
						CHECKED BY: PRW					

HALE FOAM MASTER V-Series

Venturi Based Balanced Pressure Foam Proportioning System

501-3350-00-0 FoamMaster 1.0V-12
 501-3350-01-0 FoamMaster 1.0V-24M
 501-3350-02-0 FoamMaster 1.0V-12M

501-3360-00-0 FoamMaster 2.5V-12
 501-3360-01-0 FoamMaster 2.5V-24M
 501-3360-02-0 FoamMaster 2.5V-12M

Part Number	Description	Quantity
007-1380-00-0	1/2" ID Heat Shrink Tubing with Liner	0.1 ft
007-3520-00-0	Venturi Body - 2-1/2" NPT	1
012-0160-03-0	T-Knob Handle	1
012-1480-01-0	Vehicle Mount Lever Arm, FM-V	1
018-0204-27-0	Screw - #2 - 56 x 1/2" Slotted Hex Washer	6
018-0803-16-0	Screw - #8 - 32 x 3/8" Socket Head	1
018-1004-27-0	Screw - #10 - 24 x 1/2"	7
018-1205-44-0	Screw - 1/4" - 20 x 5/8"	2
018-1210-12-0	Screw - 1/4" - 20 x 1"	2
018-1640-02-0	Screw - 3/8" - 16 x 4" Hex Head	6
018-1710-17-0	Screw - 3/8" - 24 x 1"	1
018-5002-03-0	Screw - #4 x 1/4"	4
019-0320-74-0	Panel Plate, FM-V	1
019-0390-13-0	Swivel Block, FM-V	1
029-0020-55-0	FoamMaster V-Series Manual	1
038-0200-00-0	1/8" Drain Cock (G-2311D)	1
038-1550-00-0	1/4" Check Valve	1
038-1920-00-0	Metering Valve Stem, FM-V	1
040-0120-00-0	40-2N37 Seal Ring	3
040-8200-00-0	O-Ring - 011 Teflon Impregnated Buna	2
040-8200-01-0	O-Ring - 013 Teflon Impregnated Buna	2
042-0720-00-0	Return Spring, FM-V	1
048-1340-00-0	FoamMaster Control Diagram	1
062-0541-01-0	Inboard Diaphragm HSG, FM-V	1
062-0540-02-0	Outboard Diaphragm HSG, FM-V	1
070-0500-00-0	Cover Plate, FM-V	1
073-0140-00-0	Piston / Check Valve, FM-V	1
077-2620-21-0	Retaining Ring #262 SST	1
082-0107-02-0	Fitting - 1/8" NPT x 3/8" Tube (Compression)	1
082-0203-02-0	Elbow - 1/4" NPT x 3/8" Tube (Compression)	3
082-0219-02-0	Fitting - 1/4" NPTM x 1/4" Tube (compression)	1
082-0253-02-0	Nipple - 1/4" NPT HEX	3
082-0257-02-0	Elbow - 1/4" NPT Brass Service	3
082-0302-02-0	Bushing - 3/8" x 1/4" NPT Brass	3
082-0336-02-0	Fitting - 3/8" NPT x 1/2" Hose	1
082-0406-00-0	Fitting - 1/2" NPT x 1/2" Hose	1
097-0020-02-0	Washer - 1/4" SST Flat	2
097-0140-02-0	Washer - 3/8" 300-Series SST Lock	6
097-0680-01-0	Washer - 3/8" 300-Series SST Flat	4
097-1410-00-0	Washer - 1/4" ID Fiber	2

ECO NO	REV	CHANGED FROM	BY	DATE	APVD	HALE PRODUCTS, INC A Unit of IDEX Corporation Conshohocken, PA 19428 USA				
01-392	C	Update to new Format	PRW	11/7/2001	MAL					COPYRIGHT © NOT TO BE REPRODUCED OR USED TO MAKE OTHER DRAWINGS OR MACHINERY
							DRAWN BY:	PRW	ISSUE DATE:	
						CHECKED BY:	PRW	111/7/2001		

HALE FOAM MASTER V-Series

Venturi Based Balanced Pressure Foam Proportioning System

Part Number	Description	Quantity
097-2120-00-0	Piston Washer – Large, FM-V	1
097-2120-01-0	Piston Washer - Small, FM-V	1
097-2120-02-0	Piston Seal Washer - Large, FM-V	1
097-2120-03-0	Piston Seal Washer - Small, FM-V	1
101-0500-00-0	Serial Number Nameplate	1
101-1780-02-0	FM-V Series Placard	1
110-0200-06-0	Nut - #2 - 56 SST Hex	6
110-1008-06-0	Nut - #10 - 24 SST	7
110-1200-06-0	Nut - 1/4" - 20 300-Series SST	2
110-1204-06-0	Nut - 1/4" - 20 SST Lock	1
110-1600-06-0	Nut - 3/8" - 16 300-Series SST Hex	2
200-0440-08-0	Fuse - 20A Blade Type (1.0V Models Only)	1
200-0440-10-0	Fuse - 40A Blade Type (2.5V Models Only)	1
200-0540-20-0	LED Lamp Assembly - Green (12-Volt Models Only)	1
200-0540-21-0	LED Lamp Assembly - Green (24-Volt Models Only)	1
200-1380-00-0	Proximity Reed Switch, SM-201	1
200-1380-01-0	Proximity Switch Actuator, S-2	1
200-1380-02-0	Proximity Reed Switch, SM-100	1
200-1400-00-0	Relay - FM-V (12-Volt Models Only)	1
200-1400-01-0	Relay - FM-V (24-Volt Models Only)	1
200-1420-02-0	16-14 Gauge Sealed Butt Connector	2
200-1430-00-0	Weather-Pack Seal, Red	2
200-1440-00-0	18 - 20 Gauge Female Terminal, Tower Half	2
200-1450-00-0	Two-Contact Tower Half	1
242-0270-00-0	Hose Clamp #34 (.75 - 1.06 Diameter)	2
242-0940-02-0	Fitting - Bulkhead	1
340-0180-01-1	1/2" ID Reinforced PVC Hose	10 ft
501-3420-00-0	FoamMaster 1.0V Transfer Pump (1.0V-12 Model Only)	1
501-3420-01-0	FoamMaster 2.5V Transfer Pump (2.5V-12 Model Only)	1
501-3420-02-0	FoamMaster 1.0V Transfer Pump (1.0V-24 Model Only)	1
501-3420-03-0	FoamMaster 2.5V Transfer Pump (2.5V-24 Model Only)	1
510-0200-00-0	Filter Assembly, FM-V	1
513-0230-02-0	Cable - Metering Valve, FM-V	1
513-0240-03-0	Wiring Harness, FM-V	1

ECO NO	REV	CHANGED FROM	BY	DATE	APVD	 HALE PRODUCTS, INC A Unit of IDEX Corporation Conshohocken, PA 19428 USA			
01-392	C	Update to new Format	PRW	11/7/2001	MAL				
						CHECKED BY:	PRW	11/17/2001	NOT TO BE REPRODUCED OR USED TO MAKE OTHER DRAWINGS OR MACHINERY

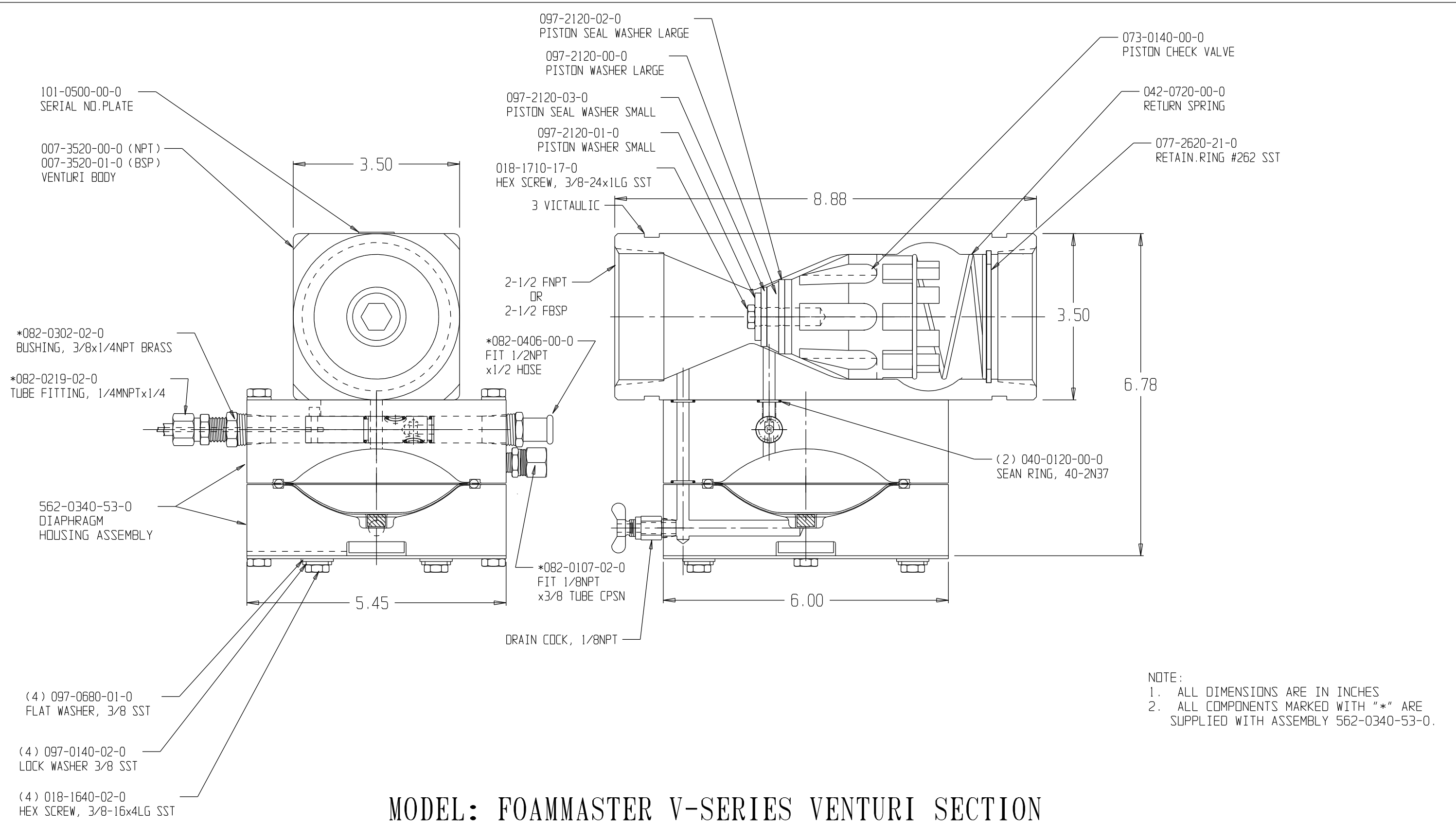



PLATE NO. EQ725AE

ECO NO	REV	CHANGED FROM	BY	DATE	APVD	ECO NO	REV	CHANGED FROM	BY	DATE	APVD
01-131	D	CREATED ASSEMBLY 562-0340-03-0	SS	2-13-98	MAL	TN98-5	.	RELEASED	MS	2-13-98	MS
01-315	E	562-0340-53-0 WAS 562-0340-01-0	JBS	8-15-01	MAL	TN98-40	A	ADDED BSP THREADS	MS	6-18-98	MS
						01-066	B	062-0540-01-0 & 082-0336-02-0 REPLACED	SS	12-13-00	MAL
						01-116	C	INDUARD HSG. & MISC. MADE INTO ASSEMBLY	SS	03-07-01	MAL



HALE PRODUCTS, INC.
A Unit of IDEX Corporation
Conshohocken, PA 19428 USA

COPYRIGHT © 1998 IDEX CORPORATION
NOT TO BE REPRODUCED OR USED TO MAKE OTHER DRAWINGS OR MACHINERY.

DRAWN: MS
CHECKED: MS
DATE: 1-15-98
SIZE: B
SCALE: NONE

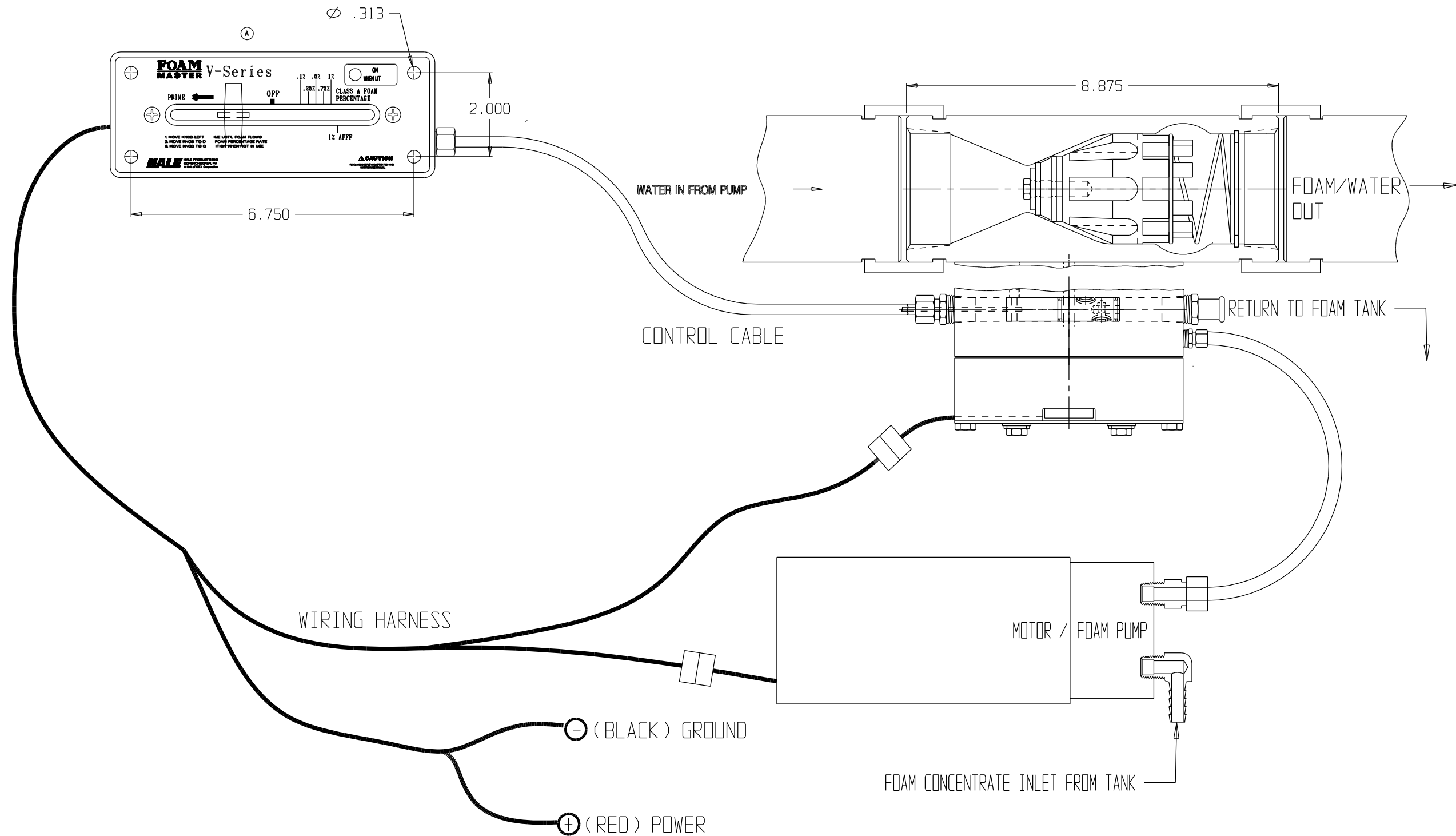

FOAMMASTER V-SERIES SYSTEM DIAGRAM

PLATE NO. EQ727A

ECO NO	REV	CHANGED FROM	BY	DATE	APVD
TN98-40	.	RELEASED	MS	6-16-98	MS
TN99-7	A	VEHICLE-MOUNT PANEL	CJ	2-15-99	JK

HALE HALE PRODUCTS, INC.
A Unit of IDEX Corporation
Conshohocken, PA 19428 USA

COPYRIGHT © NOT TO BE REPRODUCED OR USED TO MAKE OTHER DRAWINGS OR MACHINERY. DRAWN: MS CHECKED: MS DATE 6-16-98 SIZE A SCALE: NONE

PERCENT FOAM

HALE

HALE PRODUCTS, INC.
A Unit of IDEX Corporation
Conshohocken, PA 19428 USA

FOAMMASTER V-SERIES

INLET: 2.5"	OUTLET: 2.5"
2.5 FNPT AND 3" VICTAULIC	
MAXIMUM PERFORMANCE	
WITH CHECK VALVE	
DATE: 1/5/98	
CLASS A FOAM	

UNIT MODEL
FOAMMASTER
2.5V & 1.0V MECHANICAL
FOAM PROPORTIONER

EDC-085

1.5
1.25
1.0
.75
.5
.25
%

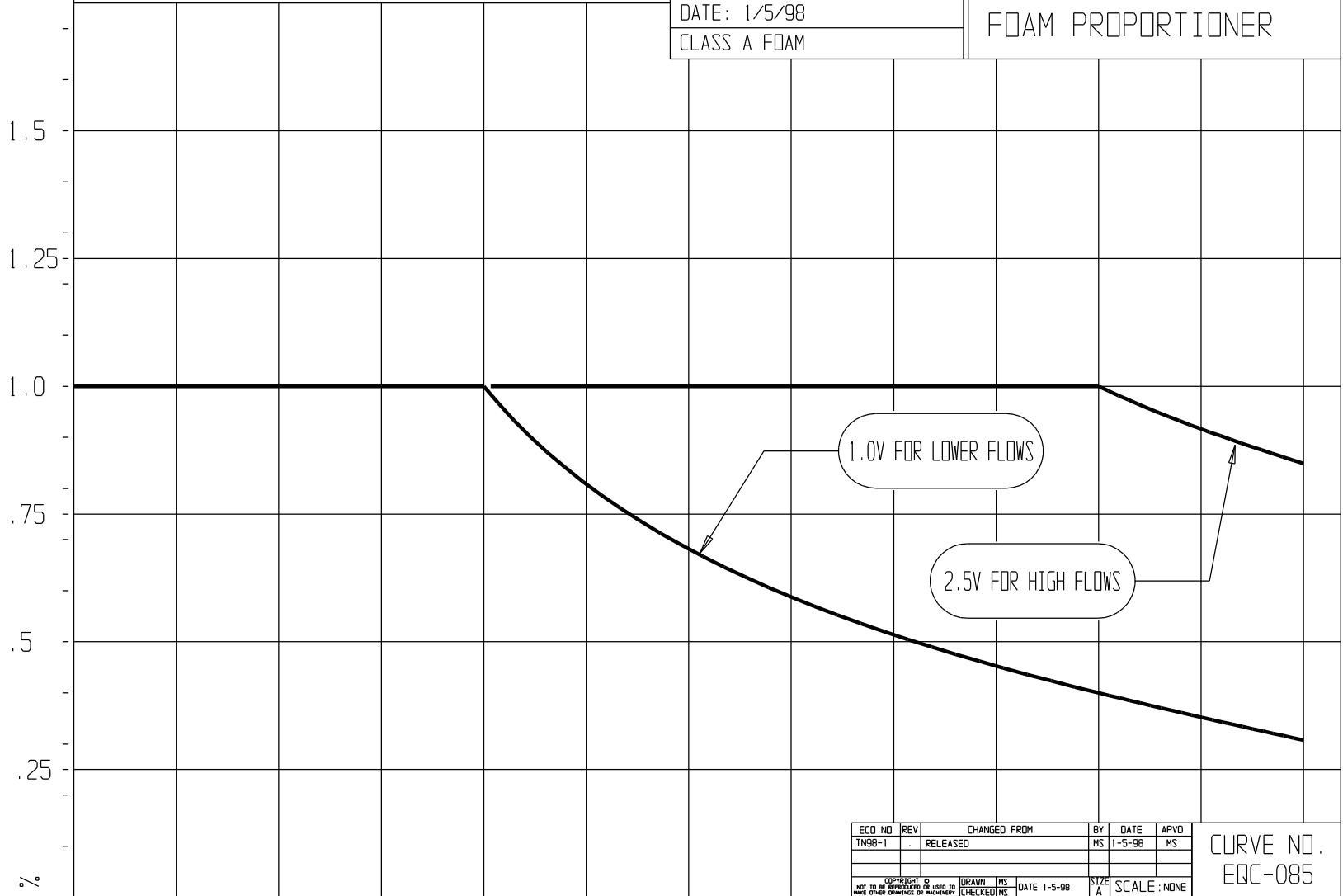

ECO NO	REV	CHANGED FROM	BY	DATE	APVD
TN98-1	.	RELEASED	MS	1-5-98	MS

CURVE NO.
EDC-085

U.S. G.P.M.	0	25	50	75	100	125	150	175	200	225	250	275	300
LITERS/MIN	0	125	250	375	500	625	750	875	1000	1125			

PRESSURE DROP

HALE

HALE PRODUCTS, INC.
A Unit of IDEX Corporation
Conshohocken, PA 19428 USA

FOAMMASTER V-SERIES

INLET: 2.5"	OUTLET: 2.5"
2.5 FNPT AND 3" VICTAULIC	
PRESSURE DROP ACROSS	
VENTURI WITH CHECK VALVE	
DATE: 1/28/98	
WATER / CLASS A FOAM	

UNIT MODEL
FOAMMASTER
2.5V & 1.0V MECHANICAL
FOAM PROPORTIONER

EDC-086

75

62.5

50

37.5

25

12.5

PSI

U.S. G.P.M.

0 25 50 75 100 125 150 175 200 225 250 275 300

LITERS/MIN

0 125 250 375 500 625 750 875 1000 1125

ECO NO	REV	CHANGED FROM	BY	DATE	APVD
TN98-5	.	RELEASED	MS	1-28-98	MS

CURVE NO.
EDC-086

COPYRIGHT ©
NOT TO BE REPRODUCED OR USED TO
MAKE OTHER DRAWINGS OR MACHINERY

DRAWN	MS	DATE	1-28-98	SIZE	A	SCALE	NONE
CHECKED	MS						

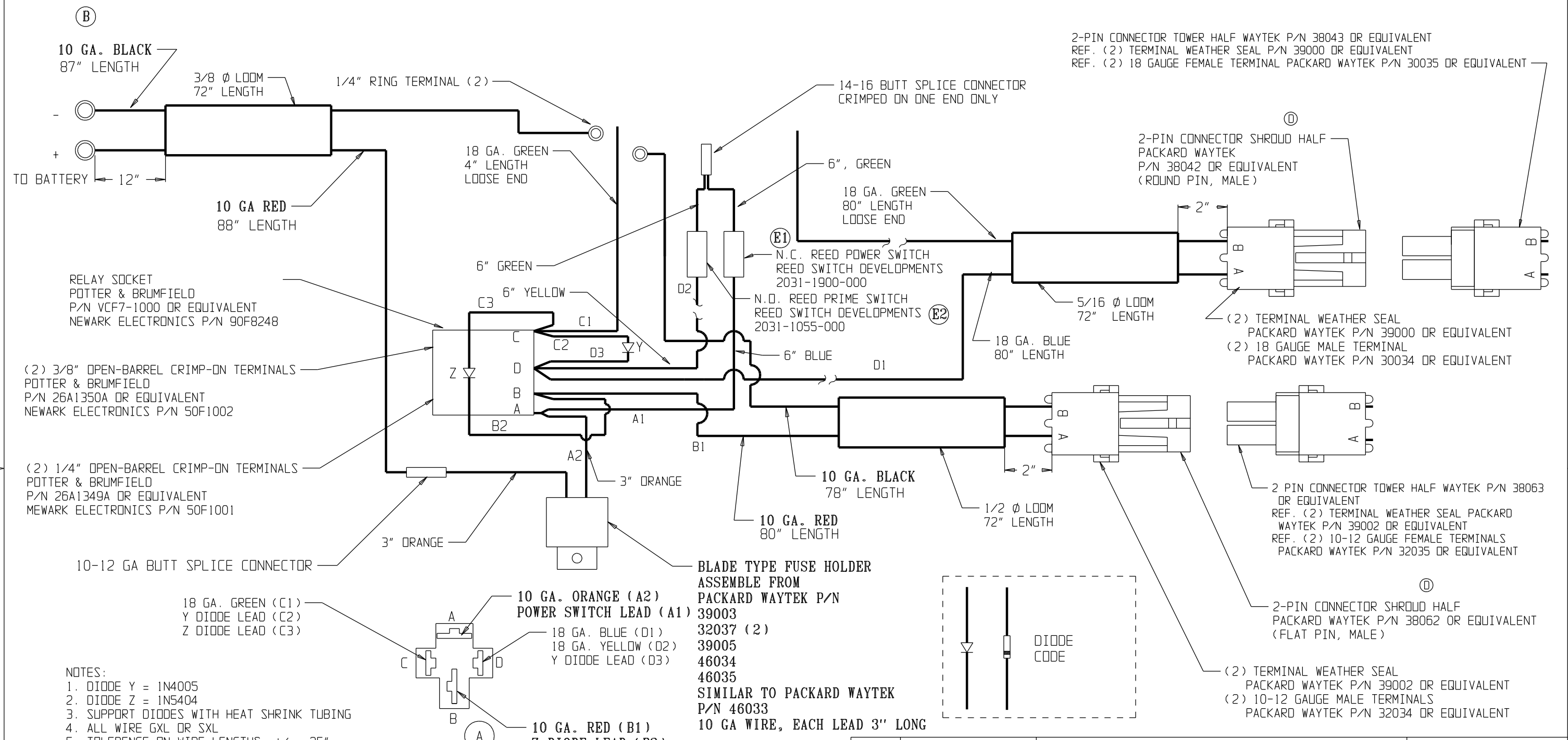

2-PIN CONNECTOR TOWER HALF WAYTEK P/N 38043 OR EQUIVALENT
 REF. (2) TERMINAL WEATHER SEAL P/N 39000 OR EQUIVALENT
 REF. (2) 18 GAUGE FEMALE TERMINAL PACKARD WAYTEK P/N 30035 OR EQUIVALENT

2-PIN CONNECTOR SHROUD HALF
 PACKARD WAYTEK
 P/N 38042 OR EQUIVALENT
 (ROUND PIN, MALE)

(2) TERMINAL WEATHER SEAL
 PACKARD WAYTEK P/N 39000 OR EQUIVALENT
 (2) 18 GAUGE MALE TERMINAL
 PACKARD WAYTEK P/N 30034 OR EQUIVALENT

2 PIN CONNECTOR TOWER HALF WAYTEK P/N 38063
 OR EQUIVALENT
 REF. (2) TERMINAL WEATHER SEAL PACKARD
 WAYTEK P/N 39002 OR EQUIVALENT
 REF. (2) 10-12 GAUGE FEMALE TERMINALS
 PACKARD WAYTEK P/N 32035 OR EQUIVALENT

2-PIN CONNECTOR SHROUD HALF
 PACKARD WAYTEK P/N 38062 OR EQUIVALENT
 (FLAT PIN, MALE)

(2) TERMINAL WEATHER SEAL
 PACKARD WAYTEK P/N 39002 OR EQUIVALENT
 (2) 10-12 GAUGE MALE TERMINALS
 PACKARD WAYTEK P/N 32034 OR EQUIVALENT

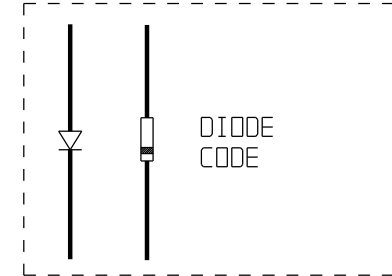

BLADE TYPE FUSE HOLDER
 ASSEMBLE FROM
 PACKARD WAYTEK P/N
 39003
 32037 (2)
 39005
 46034
 46035
 SIMILAR TO PACKARD WAYTEK
 P/N 46033
 10 GA WIRE, EACH LEAD 3\"/>

- NOTES:
1. DIODE Y = 1N4005
 2. DIODE Z = 1N5404
 3. SUPPORT DIODES WITH HEAT SHRINK TUBING
 4. ALL WIRE GXL OR SXL
 5. TOLERANCE ON WIRE LENGTHS: +/- .25"
 6. SM201 AND SM100 REED SWITCHES SOURCED FROM REED SWITCH DEVELOPMENTS CO., INC. 1405- 16th ST./ RACINE, WI 53403-2249 PH:414-637-8848, FAX:414-637-8861

ITEM NO.	PART NUMBER	DESCRIPTION	NOMINAL STOCK SIZE												
ECD NO	REV	CHANGED FROM	BY	DATE	APVD	ECD NO	REV	CHANGED FROM	BY	DATE	APVD	REPORT ERRORS & CHANGES REMOVE ALL SHARP EDGES UNLESS OTHERWISE SPECIFIED DIMENSIONS ARE IN INCHES. TOLERANCE ON: DECIMALS .XX ± .060 ANGLES .XXX ± .030 ± 1°		HALE HALE PRODUCTS, INC. A Unit of IDEX Corporation Conshohocken, PA 19428 USA TITLE WIRE HARNESS	
01-144	E	E1 WAS SM201/202, E2 WAS SM100	MS	03-21-01	MAL	TN98-33	.	RELEASED	MS	5-21-98	MS	SIZE B	FIRST USED ON V-SERIES		DWG NO. 513-0240-03-0
						TN98-56	A	SWITCHED TERM A & B	MS	8-24-98	MS	SCALE: NONE	CAD LEVELS:	SHEET of	
						TN99-7	B	10 GA WIRE	CJ	2-8-99	JK	COPYRIGHT © NOT TO BE REPRODUCED OR USED TO MAKE OTHER DRAWINGS OR MACHINERY. DRAWN CJ CHECKED MS DATE 12-23-97			
						TN00-16	C	ADDED SM202	JK	05/10/00	JK				
						TN00-20	D	(2) MALE BODY (2) ADDED TOWER HALF	CK	5-31-00	JK				