



SmartCAFS

Compressed Air Foam Systems

Models:

Manifold – Qmax, Qmax-XS, Qtwo

Volute – DSD

CAFS TROUBLESHOOTING GUIDE

FSG-MNL-00177

HALE PRODUCTS, INC / CLASS 1

607 NW 27th Avenue • Ocala, FL 34475

U.S.A. Telephone: 352-629-5020

FAX: 800-533-3569

GODIVA LTD.

Charles Street • Warwick, England CV34 5LR

Phone: 44-1-926-623600





BEFORE USING THE SYSTEM THE FULL MANUAL SHOULD BE READ AND PERSONNEL TRAINED. THIS IS FOR REFERENCE PURPOSES ONLY.

ON-SCREEN WARNINGS AND INFORMATION

The SmartCAFS Controller uses on-screen pop-up warnings and information to indicate system status to the operator.

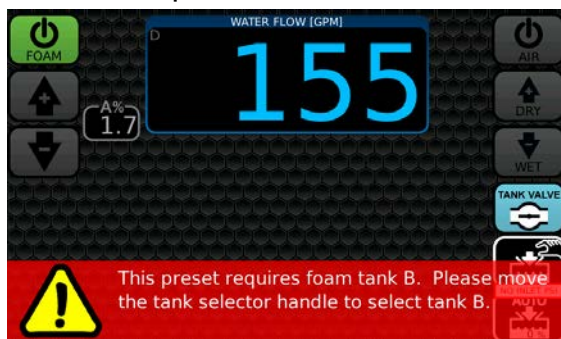



Figure 1 Warnings use a red background

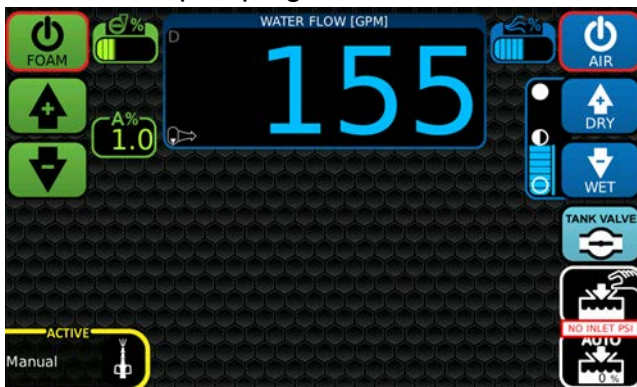



Figure 2 Information uses a blue background

Touch the warning/information to dismiss it (inhibited). The warning will be hidden for the number of seconds set in the OEM menu's "warning inhibit timeout". If the condition that caused the warning still exists the warning will pop-up again.

CAFS - Setting the Air Balance control Valves

1. Symptoms of Improper Adjustment
 - a. Air pressure fluctuates or bounces too far from water pressure on the duplex gauge:
 - i. The snubber valve is open too much
 - b. A “popping” sound is observed within the air intake filter & ducting:
 - i. The snubber valve is closed too much.
2. Functionally Test Smart CAFS Air Pressure /Water Pressure & Adjust Match
 - a. The water pump should be running at 700-800 RPM and discharging water.
 - b. Turn system ON by pressing . LED bar graph on display should light up and foam should start pumping.



- c. Close the discharge valve completely on the CAFS manifold.
- d. While observing the duplex gauge, engage compressor clutch with the **BLUE AIR** power button  and increase engine speed and pump pressure to 75 PSI. Air pressure should follow & match while maintaining a stable reading.
- e. Adjust the flow valve located on the side of the air intake to increase or decrease the air flow/pressure for the compressor. Adjust the snubber valve on intake valve body (located on the top of the air compressor) to dampen out pulses and fluctuations to achieve smooth operation as indicated on the duplex gauge.
- f. Lock in place with lock nut. Repeat for “g” through “i” to fine tune compressor air pressure/water pressure match.

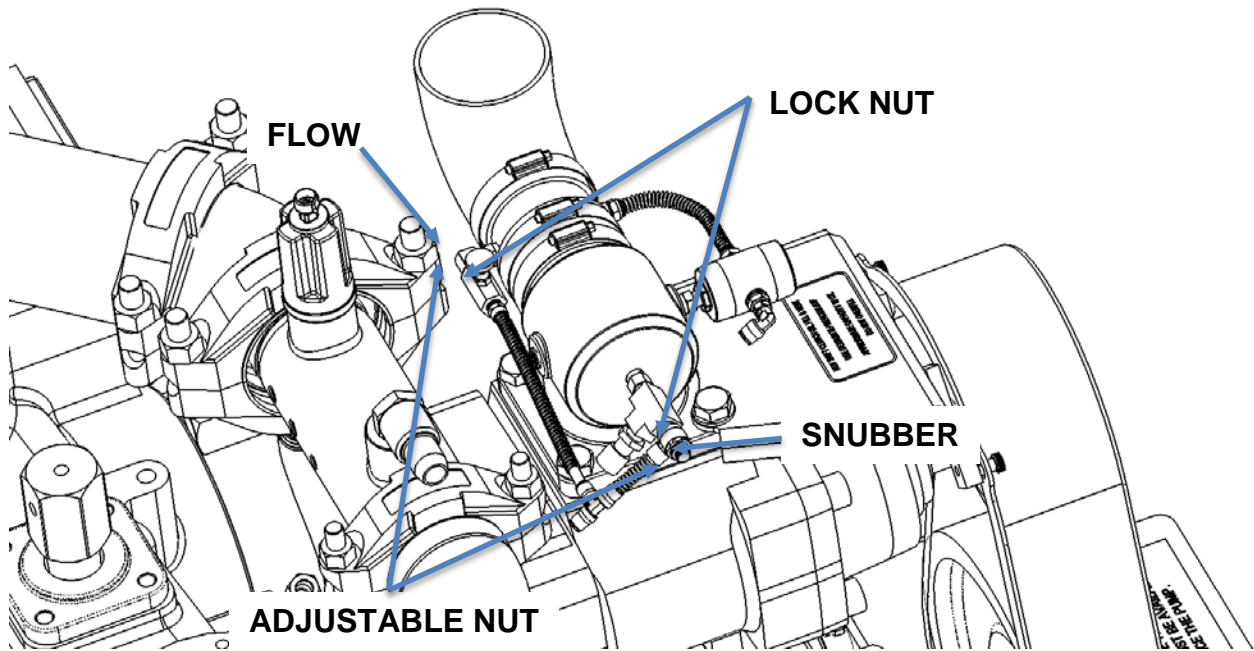

Figure 3 Compressor Intake Adjustment

- g. Increase engine speed to 100 psi. Air pressure should follow.
 - h. Increase engine speed to 125 psi. Air pressure should follow.
 - i. Increase engine speed to 150 psi. Air pressure should follow.
 - j. Slowly reduce engine speed to 900 RPM. (Compressor will make howling noise that is much louder if speed is reduced quickly).
3. If the system is still not tracking then there might be an issue with the air balance valve.
- a. If you can't get the system to go wet, but can get it to go dry or there is a large delay in air pressure when increasing/decreasing water pressure. Grease the o-ring indicated in Figure 46.
 - b. If you can't get the pressure to match in either wet or dry operation the air balance valve may be damaged. Remove the air balance valve and measure the ID of the water pressure inlet, if it is less than 5.97 mm it may be damaged.

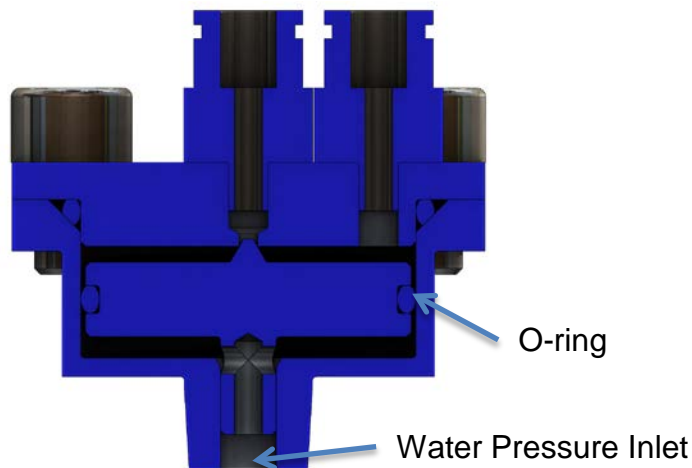



Figure 4 Air Balance Valve (61215) Cross Section

CAFS – Hot Shift Clutch Engagement

1. The hot shift clutch is engaged when the CAFS switch is activated.
 - a. Pressing the CAFS enable switch to engage the hot shift clutch. “
 - b. Pressing the  on the screen or button for 3 seconds will disengage the hot shift clutch.



2. When the CAFS switch is activated, the clutch solenoid valve is then energized allowing pressurised air to engage the clutch.
3. Setting the hot shift clutch engagement:
 - a. The solenoid valve controls how fast or slow the hot shift clutch engages.
 - b. There is a flow control valve located on the air output side of the solenoid valve. Adjusting this flow control causes the hot shift clutch to engage faster or slower.
 - i. Adjusting (closing) the flow control to engage the clutch too slowly will reduce the life of the clutch itself.
 - ii. Adjusting (opening) the flow control to engage the too quickly will cause the pump to “shutter” & possibly cause the drive belt to jump a tooth.
 - c. The standard HALE set point for the flow control is the following:
 - i. Loosen the set screw on the side of the adjustment knob.
 - ii. Rotate the adjustment knob inward to the closed position.
 - iii. Rotate the adjustment knob outward 2-1/4 turns (until you see the beginning of the blue ring)
 - iv. Lock the adjustment knob's position by tightening the set screw on the side of the adjustment knob.
 - d. Fine tuning beyond the standard set point may be necessary. This is completed by engaging the clutch & observing the performance of the pumping system & the compressor. Adjusting the flow control in or out slightly as needed after disengaging & re-engaging the clutch for best performance. Allow the pumping system to settle 5~10 seconds between engage & disengage cycles while adjustments are made.

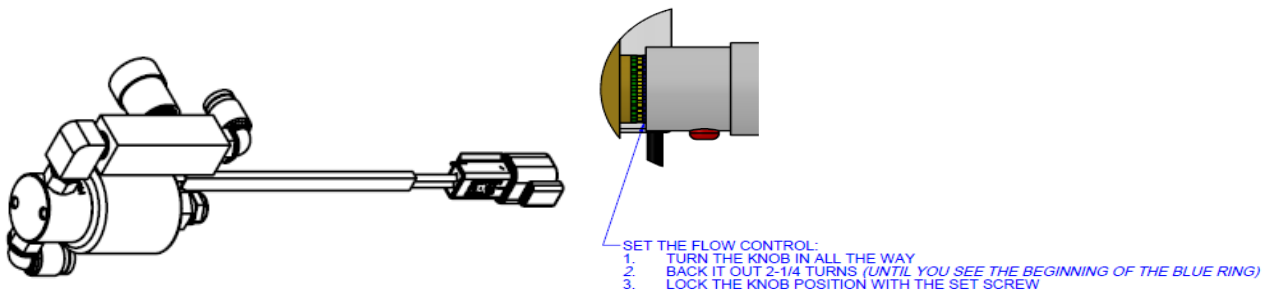

QUICK REFERENCE GUIDE/TROUBLESHOOTING

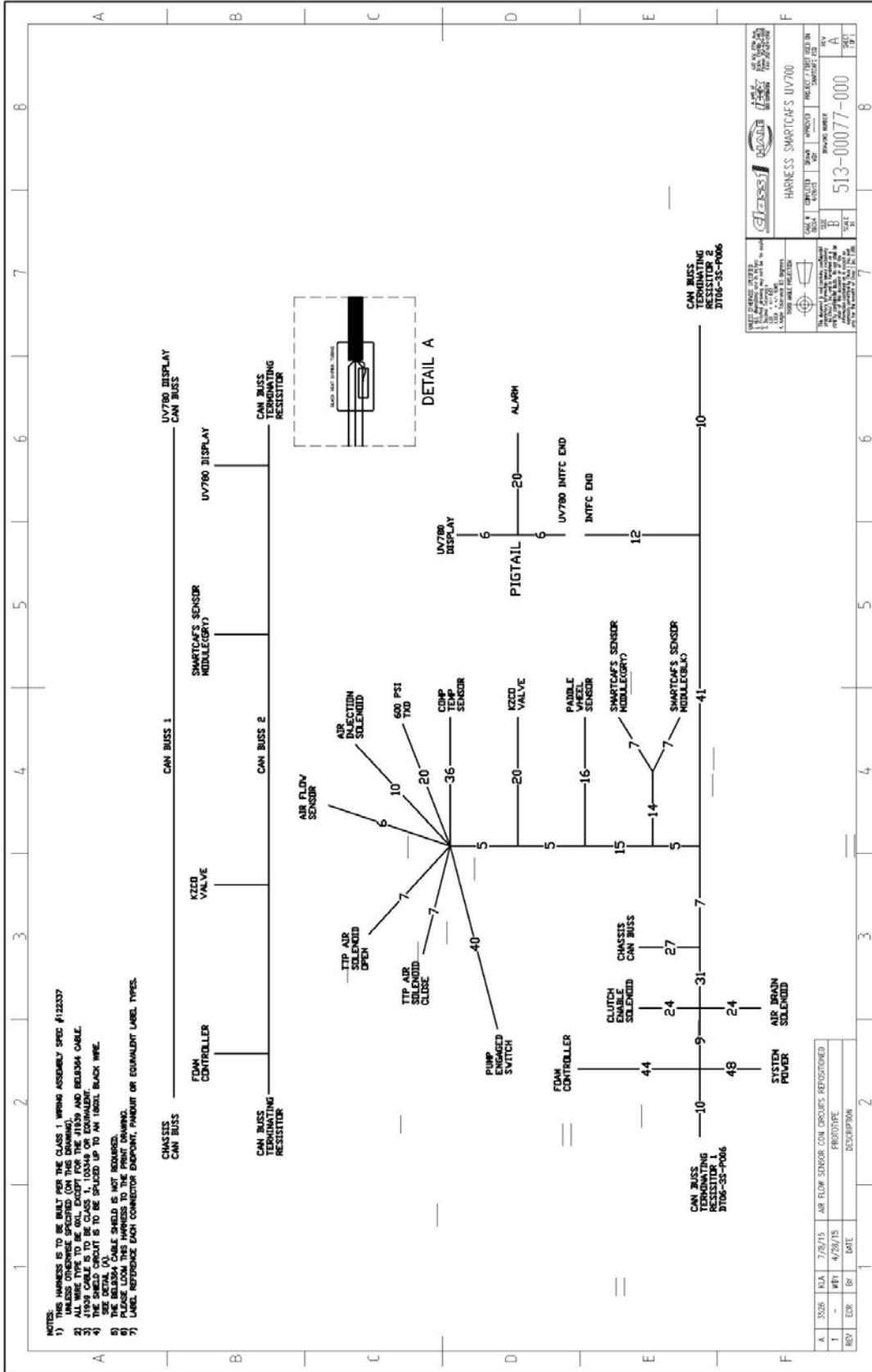

AIR INJECTION/Control

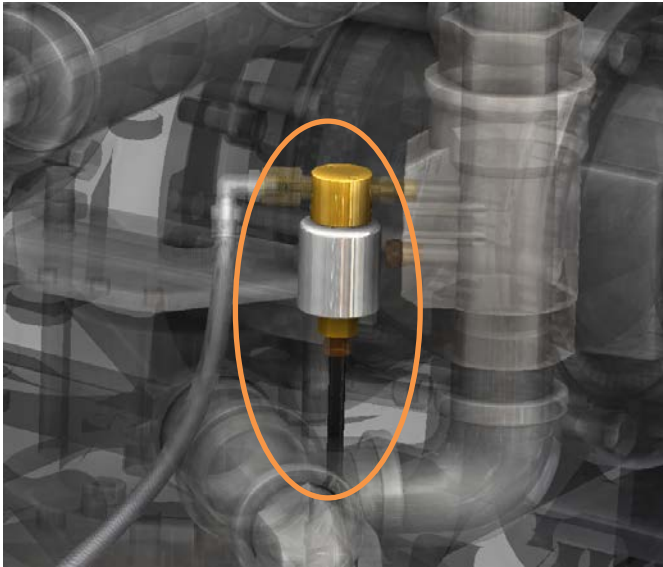

PART NUMBER	12V: 038-00043-010 24V: 038-00043-000
DESCRIPTION	Air Inject Solenoid
OPERATION	Controls the air supply to the air inject valve. When the air is supplied to the air valve it allows air to be injected into the system.
POSSIBLE FAULT	<ul style="list-style-type: none"> • No Air Injection <ul style="list-style-type: none"> ○ No power being supplied to solenoid. ○ Solenoid is clogged. ○ Solenoid has failed.

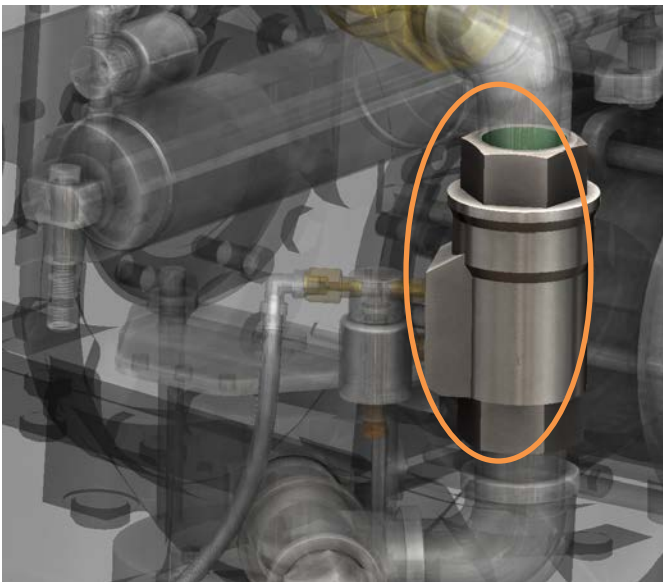

PART NUMBER	59107-02
DESCRIPTION	Air Inject Valve
OPERATION	Controls the air injection into the water/foam manifold. When this receives air from the air solenoid it has a plunger that lifts from its seat to allow air to pass through.
POSSIBLE FAULT	<ul style="list-style-type: none"> • Not opening <ul style="list-style-type: none"> ○ No air from solenoid. ○ Air port from solenoid is clogged. • Not closing <ul style="list-style-type: none"> ○ Valve seat is dirty. ○ Valve seal has failed.



PART NUMBER	200-00108
DESCRIPTION	Air Pressure Detect Transducer
OPERATION	This transducer reads air pressure. Once this transducer senses 5 psi it disables the clutch from engaging. This also controls the interlock for air injection. It also provides the air pressure readout on the display.
POSSIBLE FAULT	<ul style="list-style-type: none"> • Air is not injecting <ul style="list-style-type: none"> ○ Transducer not detecting air pressure. ○ No power to transducer. ○ Transducer has failed. • Clutch is not engaging <ul style="list-style-type: none"> ○ Air pressure > 5 psi detected. ○ No power to transducer. ○ Transducer has failed.

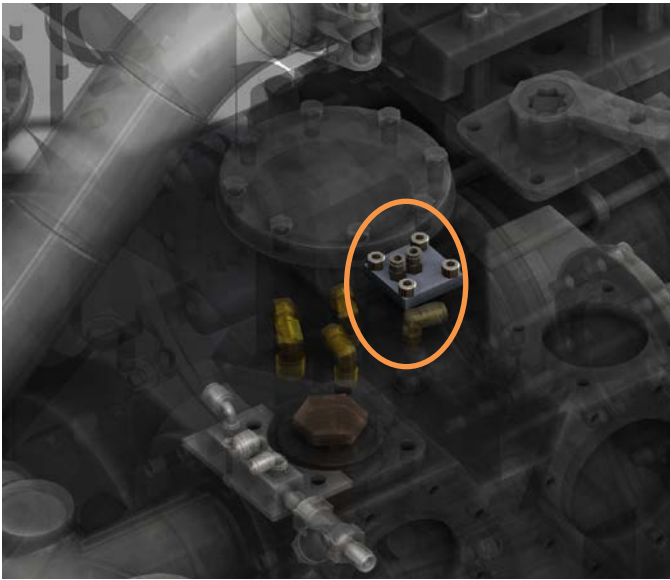

PART NUMBER	61215
DESCRIPTION	Air Balance Valve
OPERATION	Controls the air intake valve for the compressor in order to match the air to the water pressure. Air is injected from the outside port onto a plunger which is raised and lowered by the water pressure from the other side to choke and open the air intake for the compressor.
POSSIBLE FAULT	<ul style="list-style-type: none"> • Air is not matching <ul style="list-style-type: none"> ○ O-ring needs to be greased ○ Water inlet has been crushed preventing the plunger from moving properly. <p>See “CAFS - Setting the Air Balance control Valves” on page 2.</p>



PART NUMBER	038-1470-03-0
DESCRIPTION	Air Intake Valve
OPERATION	Controls the amount of air going into the compressor. This in turn controls the amount of air being injected into the system. The farther open the plunger the more air being injected. The plunger is balanced
POSSIBLE FAULT	<ul style="list-style-type: none"> • No air injection <ul style="list-style-type: none"> ○ Too much air pressure from the control side of the air intake valve from the air balance valve • Pressure match isn't smooth <ul style="list-style-type: none"> ○ Plunger is sticking • Pressure isn't matching <ul style="list-style-type: none"> ○ See instructions on page 2. • Air leaks <ul style="list-style-type: none"> ○ O-ring/Seal is bad ○ Bolts to compressor are loose.



PART NUMBER	038-1560-00-0
DESCRIPTION	Blow Down Valve
OPERATION	Releases built up pressure in air system. Air pressure is supplied from the oil separator and the air intake. If they don't match the valve opens connection from the oil separator to atmosphere
POSSIBLE FAULT	<ul style="list-style-type: none"> • Air leaks <ul style="list-style-type: none"> ○ Valve is bad ○ Fittings are loose



PART NUMBER	038-00071-001
DESCRIPTION	Air Relief Valve
OPERATION	This valve relieves pressure from the control side of the air intake valve. Any pressure above the required pressure to close the air intake valve will be released. This improves the tracking speed for the pressure match, especially when reducing water pressure.
POSSIBLE FAULT	<ul style="list-style-type: none"> • Pressure isn't matching <ul style="list-style-type: none"> ○ Relief pressure is set too low. Tighten to increase relief pressure. • Air leaks <ul style="list-style-type: none"> ○ O-ring/Seal is bad



PART NUMBER	70141
DESCRIPTION	Air Intake Control Needle Valve
OPERATION	This valve controls the amount of air pressure limiting the air intake. The larger the air pressure the lower the air flow into the compressor. It also dampens the response of the air intake plunger.
POSSIBLE FAULT	<ul style="list-style-type: none"> • Air/Water tracking is not steady <ul style="list-style-type: none"> ○ Needle valve is open too far. • Air/Water tracking is too slow when changing water pressure <ul style="list-style-type: none"> ○ Needle valve is closed too far. <p>See instructions on page 2.</p>

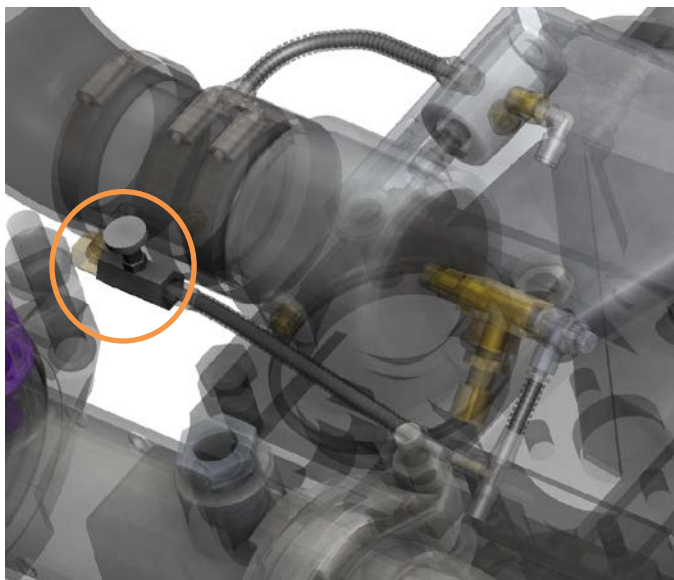

PART NUMBER	038-1680-01-0
DESCRIPTION	Air Intake Inlet Needle Valve
OPERATION	This valve controls the amount of air pressure dumping to atmosphere. The more air dumping the farther the air intake plunger opens.
POSSIBLE FAULT	<ul style="list-style-type: none"> • Air flow for wet is too great <ul style="list-style-type: none"> ○ Needle valve is open too far. • Air/Water not tracking <ul style="list-style-type: none"> ○ Needle valve is closed too far. ○ Needle valve is clogged. • Air/Water is not dry enough <ul style="list-style-type: none"> ○ Needle valve is closed too far. <p>See instructions on page 2.</p>

compressor operation

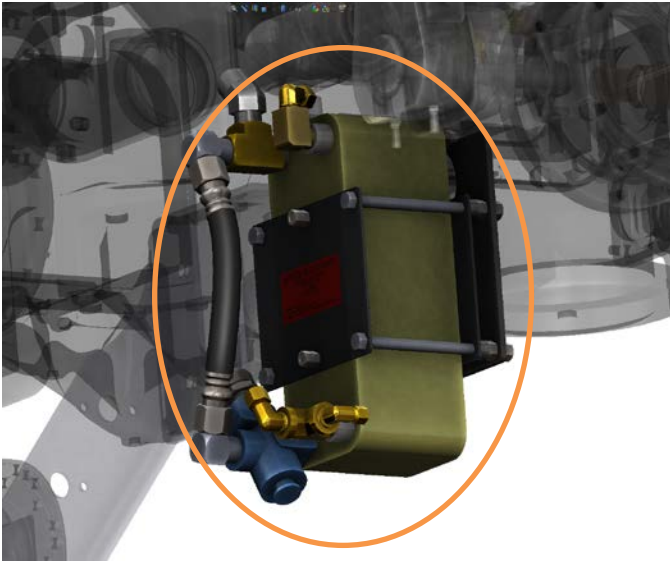

PART NUMBER	108-0641-00-0
DESCRIPTION	Heat Exchanger
OPERATION	Plate style heat exchanger cools the oil from the oil separator for the compressor with discharge water from the pump. Thermostatic Valve 038-1390-00-0 opens at 150°F (65°C) to allow the oil to run through the heat exchanger otherwise it bypasses the heat exchanger.
POSSIBLE FAULT	<ul style="list-style-type: none"> • Not opening <ul style="list-style-type: none"> ○ No air from solenoid. ○ Air port from solenoid is clogged.

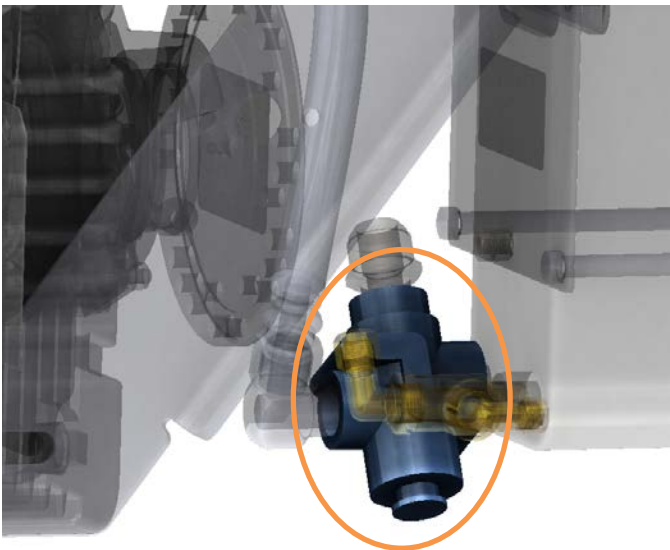

PART NUMBER	038-1390-00-0
DESCRIPTION	Thermostatic Oil Bypass Valve
OPERATION	Opens at 150°F (65°C) [fully opening at 170°F (76°C)] to allow the oil to run through the heat exchanger otherwise it bypasses the heat exchanger.
POSSIBLE FAULT	<ul style="list-style-type: none"> • Compressor is overheating <ul style="list-style-type: none"> ○ Not fully opening. ○ Oil temperature is above max operating temperature.

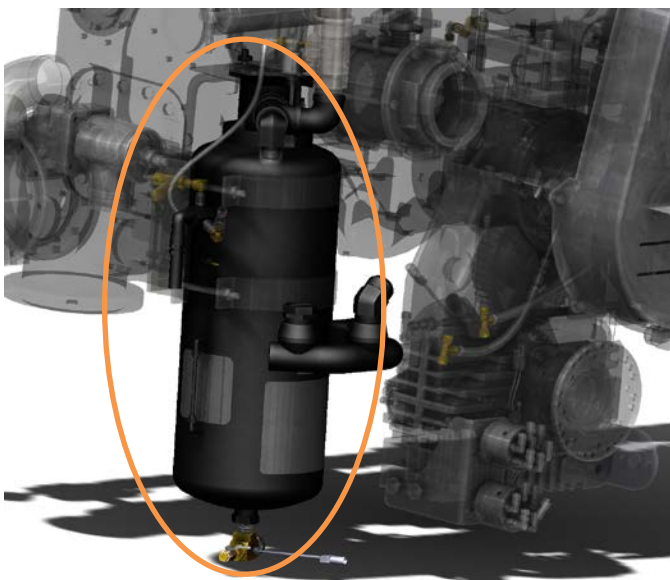

PART NUMBER	108-0630-00-0
DESCRIPTION	Oil Separator
OPERATION	Separates the air and oil through a series of chambers internally and any condensation/water, which can be drained from the bottom ball valve. The side “arm” is for replacing oil. The top port with the air valve is for discharging air to the pump or auxiliary port. The hex on the side supplies air to the control system for the compressor.
POSSIBLE FAULT	<ul style="list-style-type: none"> • Compressor is overheating <ul style="list-style-type: none"> ○ Oil is not at proper level. ○ Oil not being cooled by Heat Exchanger. • Air injection/Pressure match <ul style="list-style-type: none"> ○ Hex port on side is leaking ○ Brass orifice is missing from scavenge line.

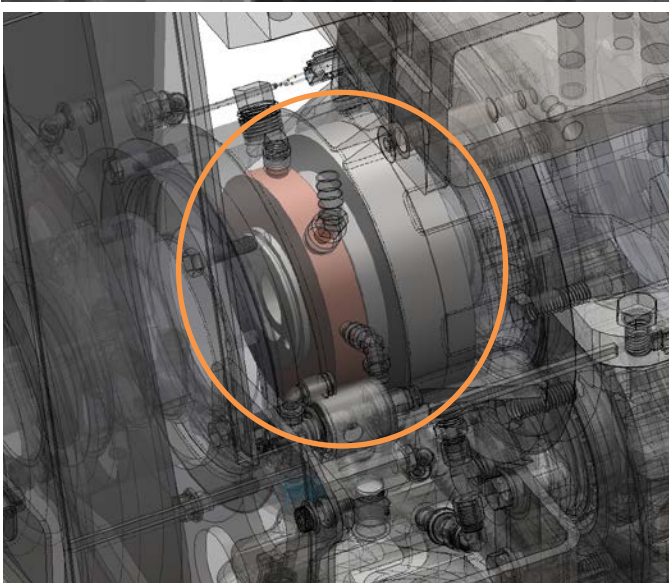
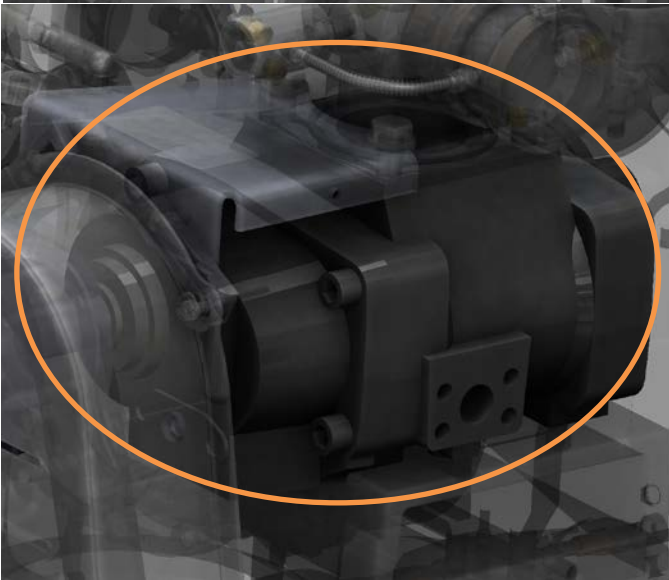
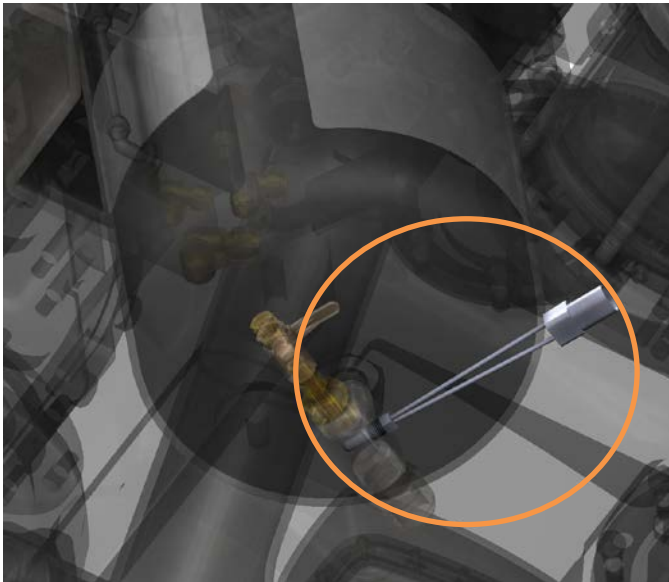

PART NUMBER	200-1161-00-0
DESCRIPTION	Oil Temperature Sensor
OPERATION	Temperature sensor enables/disables the compressor interlock. If temperature goes outside of operating range or if system loses signal from this sensor then the clutch will be disabled.
POSSIBLE FAULT	<ul style="list-style-type: none"> • Clutch is not engaging <ul style="list-style-type: none"> ○ No signal from this sensor. ○ Oil temperature is outside of operating range.
PART NUMBER	501-4140-01-0
DESCRIPTION	Compressor
OPERATION	Oil lubricated twin screw compressor is driven by gearbox by a herringbone drive belt that is enabled by a pneumatic clutch. Compressor is water cooled by plate heat exchanger. Air is supplied and controlled by the air intake valve.
POSSIBLE FAULT	<ul style="list-style-type: none"> • Clutch is not engaging <ul style="list-style-type: none"> ○ See clutch section. • Overheating <ul style="list-style-type: none"> ○ Belt is not a correct tension ○ Heat exchanger not functioning ○ Oil is not at correct level • No Air injection <ul style="list-style-type: none"> ○ Air Intake Valve isn't opening ○ Air Injection Valve isn't opening
PART NUMBER	505-0260-01-0
DESCRIPTION	Clutch
OPERATION	Pneumatic Clutch that can be set through the UV display to be engaged upon start up or only when CAFS is needed. It operates from truck air and is enabled by a solenoid. The engagement timing is controlled by a needle valve attached to the engagement solenoid.
POSSIBLE FAULT	<ul style="list-style-type: none"> • Clutch is not engaging <ul style="list-style-type: none"> ○ Clutch solenoid has failed ○ Inadequate air supply ○ Needle valve not set correctly. ○ Interlocks are enabled. • Overheating <ul style="list-style-type: none"> ○ Oil is at incorrect level ○ Plates are damaged ○ Belt is installed crooked ○ Belt is not at correct tension.

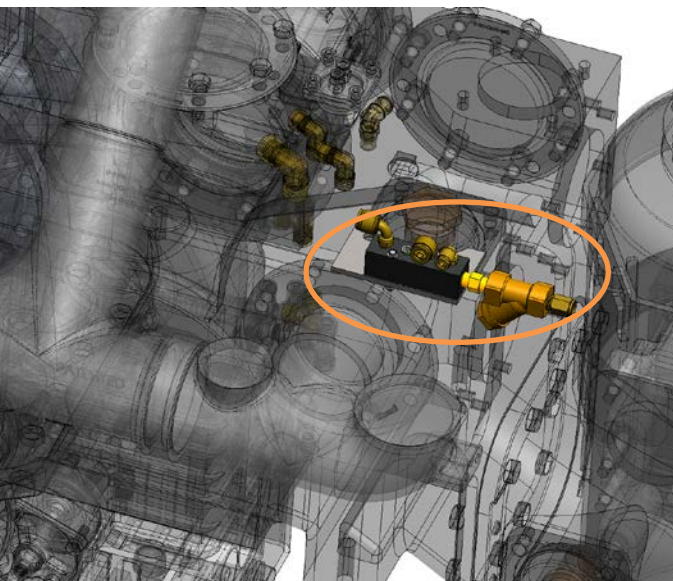
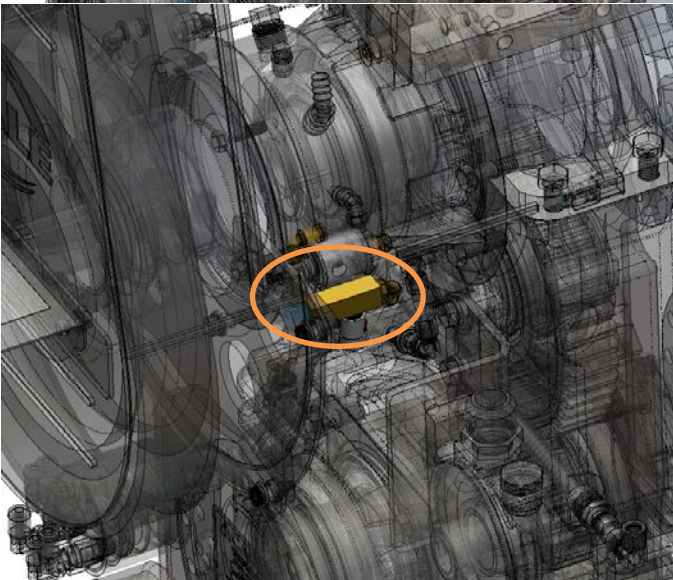
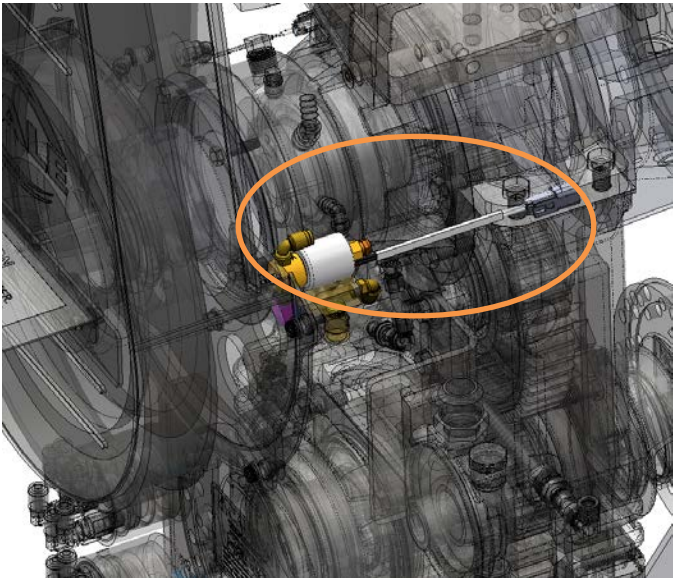

PART NUMBER	12V: 538-1910-10-0 24V: 538-1910-00-0
DESCRIPTION	Clutch Enable Solenoid
OPERATION	The clutch solenoid is normally closed. When all of the interlock conditions are met the solenoid opens and allows air to engage the clutch.
POSSIBLE FAULT	<ul style="list-style-type: none"> • Clutch is not engaging <ul style="list-style-type: none"> ○ Clutch solenoid has failed ○ Solenoid not receiving signal ○ Inadequate air supply ○ Interlocks are enabled. ○ Incorrect Solenoid is installed (Voltage or Normally Open)
PART NUMBER	038-2030-00-0
DESCRIPTION	Clutch Needle Valve
OPERATION	Clutch needle valve controls the engagement speed of the clutch by controlling the amount of air going to the clutch. Closing the needle valve slows engagement, while opening the needle valve speeds engagement.
POSSIBLE FAULT	<ul style="list-style-type: none"> • Clutch is not engaging <ul style="list-style-type: none"> ○ Clutch solenoid has failed ○ Inadequate air supply ○ Needle valve not set correctly. ○ Interlocks are enabled. <p>See “CAFS – Hot Shift Clutch Engagement” on page 4.</p>

PART NUMBER	178-1050-10-0
DESCRIPTION	Truck Air Manifold
OPERATION	This air manifold is used as an inlet from the truck air. It supplies air to the Master Drain, Tank-to-Pump, and clutch.
POSSIBLE FAULT	<p>Problems with Master Drain, Tank-to-Pump, and Clutch can be from:</p> <ul style="list-style-type: none"> • Dirty Strainer • Leaks in Manifold • No air from truck

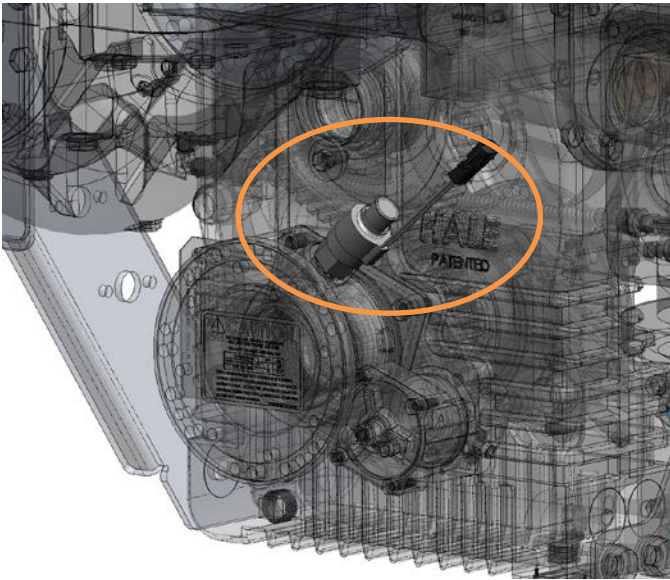

PART NUMBER	200-2610-00-0
DESCRIPTION	Tachometer
OPERATION	Tachometer reads the rotation of the drive shaft. It reports to the UV SmartCAFS display in order to meet interlock requirements for the clutch enable.
POSSIBLE FAULT	<ul style="list-style-type: none"> • Clutch is not engaging <ul style="list-style-type: none"> ○ Engine speed is too high ○ Tachometer has failed ○ Harness is damaged.

CAFS OPERATION

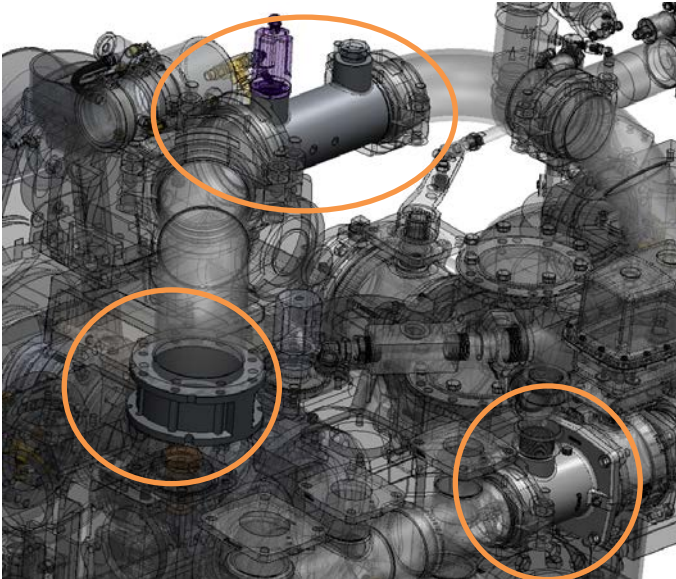

PART NUMBER	SINGLE CHECK: 538-1850-00-0 DOUBLE CHECK: 538-1840-00-0 4" WAFER: 038-1570-04-0 4" WAFER QTWO: 538-00038-001 CAFS CHECK: 114666
DESCRIPTION	Check Valves
OPERATION	The first two check valves isolate the pump from the foam, while the check valve after the ARC isolates the air from the foam. The configuration depends on the manifold ordered.
POSSIBLE FAULT	<ul style="list-style-type: none"> • Check Valve failure can result in: <ul style="list-style-type: none"> ○ Foam in the pump body ○ Poor CAFS pressure matching

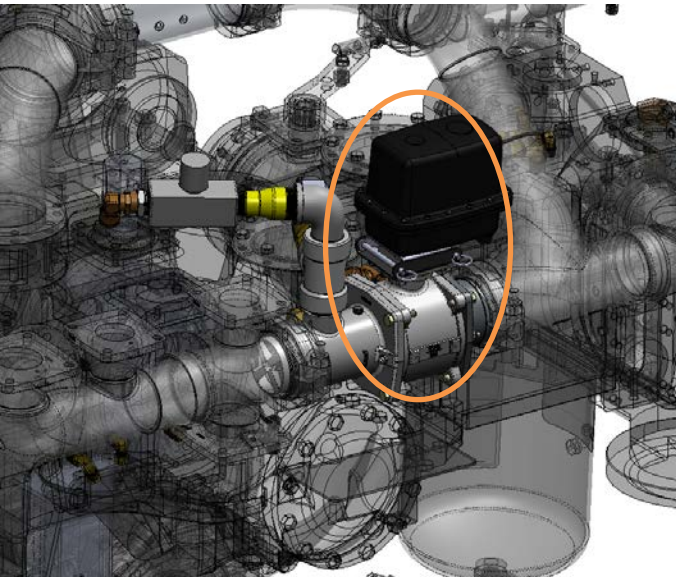

PART NUMBER	538-1900-05-0
DESCRIPTION	ARC VALVE
OPERATION	ARC valve controls the air/water ratio for CAFS operation. It automatically goes to full open when CAFS is not in operation. It is CAN controlled by the UV display. Bypass is installed for fine tuning (factory set).
POSSIBLE FAULT	<ul style="list-style-type: none"> • Poor CAFS performance <ul style="list-style-type: none"> ○ ARC is stuck <ul style="list-style-type: none"> ▪ (Remove actuator and loosen with 3/4" wrench being careful to keep the valve orientation the same when replacing valve. ▪ Grease valve ○ No signal to ARC valve

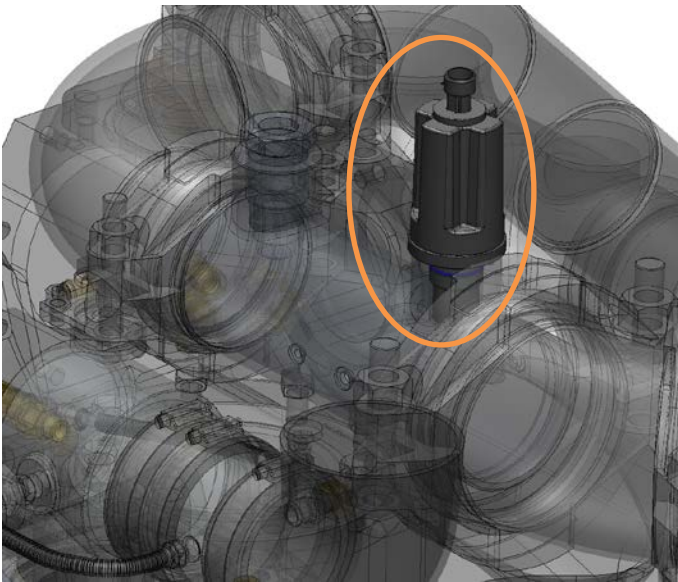

PART NUMBER	STANDARD: 102714 HIGH PRESSURE KIT: 8713198-1
DESCRIPTION	Paddlewheel
OPERATION	Paddlewheel measures the water flow before foam and air injection. The high pressure kit is for qtwo and other high pressure pump applications.
POSSIBLE FAULT	<ul style="list-style-type: none"> • No signal from paddlewheel can result in: <ul style="list-style-type: none"> ○ No foam injection ○ No air injection • Poor CAFS performance <ul style="list-style-type: none"> ○ Paddlewheel is out of calibration ○ Not properly grounded (can result in large jumps in the water flow reading).

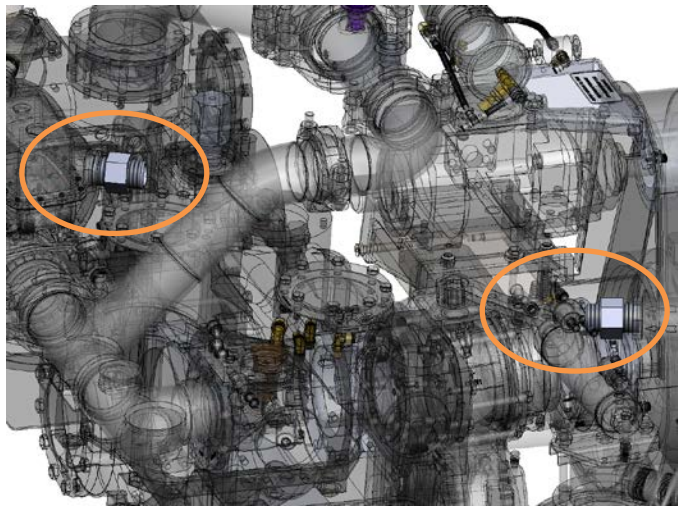

PART NUMBER	STANDARD: 038-1631-02-0
DESCRIPTION	Air Inject Check Valve
OPERATION	Air inject check valve prevents water from entering the oil separator.
POSSIBLE FAULT	<ul style="list-style-type: none"> • Check Valve failure can result in: <ul style="list-style-type: none"> ○ Water in the Oil Separator ○ Poor CAFS pressure matching

EXPRESS WARRANTY

EXPRESS WARRANTY: Hale Products, Inc (“Hale”) hereby warrants to the original buyer that products manufactured by it are free of defects in material and workmanship for one (1) year. The “Warranty Period” commences on the date the original buyer takes delivery of the product from the manufacturer.

LIMITATIONS: HALE’S obligation is expressly conditioned on the Product being:

- Subjected to normal use and service.
- Properly maintained in accordance with HALE’S Instruction Manual as to recommended services and procedures.
- Not damaged due to abuse, misuse, negligence or accidental causes.
- Not altered, modified, serviced (non-routine) or repaired other than by a Hale approved service facility.
- Manufactured per design and specifications submitted by the original Buyer.

THE ABOVE EXPRESS LIMITED WARRANTY IS EXCLUSIVE. NO OTHER EXPRESS WARRANTIES ARE MADE. SPECIFICALLY EXCLUDED ARE ANY IMPLIED WARRANTIES INCLUDED, WITHOUT LIMITATIONS, THE IMPLIED WARRANTIES OF MERCHANTABILITY OF FITNESS FOR A PARTICULAR PURPOSE OR USE; QUALITY; COURSE OF DEALING; USAGE OF TRADE; OR PATENT INFRINGEMENT FOR A PRODUCT MANUFACTURED TO ORIGINAL BUYER’S DESIGN AND SPECIFICATIONS.

EXCLUSIVE REMEDIES: If the Buyer promptly notifies HALE upon discovery of any such defect (within the Warranty Period), the following terms shall apply:

- Any notice to HALE must be in writing, identifying the Product (or component) claimed defective and circumstances surrounding its failure.
- HALE reserves the right to physically inspect the Product and require Buyer to return same to HALE’s plant or other authorized service provider.
- In such event, Buyer must notify HALE for a Returned Goods Authorization (“RGA”) number and Buyer must return the Product F.O.B. to HALE.
- If determined defective, HALE shall, at its option, repair or replace the Product, or refund the purchase price (less allowance for depreciation).
- Absent proper notice within the warranty Period, HALE shall have no further liability or obligation to Buyer therefore.

THE REMEDIES PROVIDED ARE THE SOLE AND EXCLUSIVE REMEDIES AVAILABLE. IN NO EVENT SHALL HALE BE LIABLE FOR INCIDENTAL OR COSEQUENTIAL DAMAGE(S) INCLUDING, WITHOUT LIMITATIONS, LOSS OF LIFE; PERSONAL INJURY; DAMAGE TO REAL OR PERSONAL PROPERTY DUE TO WATER OR FIRE; TRADE OR OTHER COMMERCIAL LOSSES ARISING, DIRECTLY OR INDIRECTLY, OUT OF PRODUCT FAILURE.