

12.5  
[318]

# HALE FYR-PAK

UNIT WEIGHT: 34 POUNDS (15.5 kg)

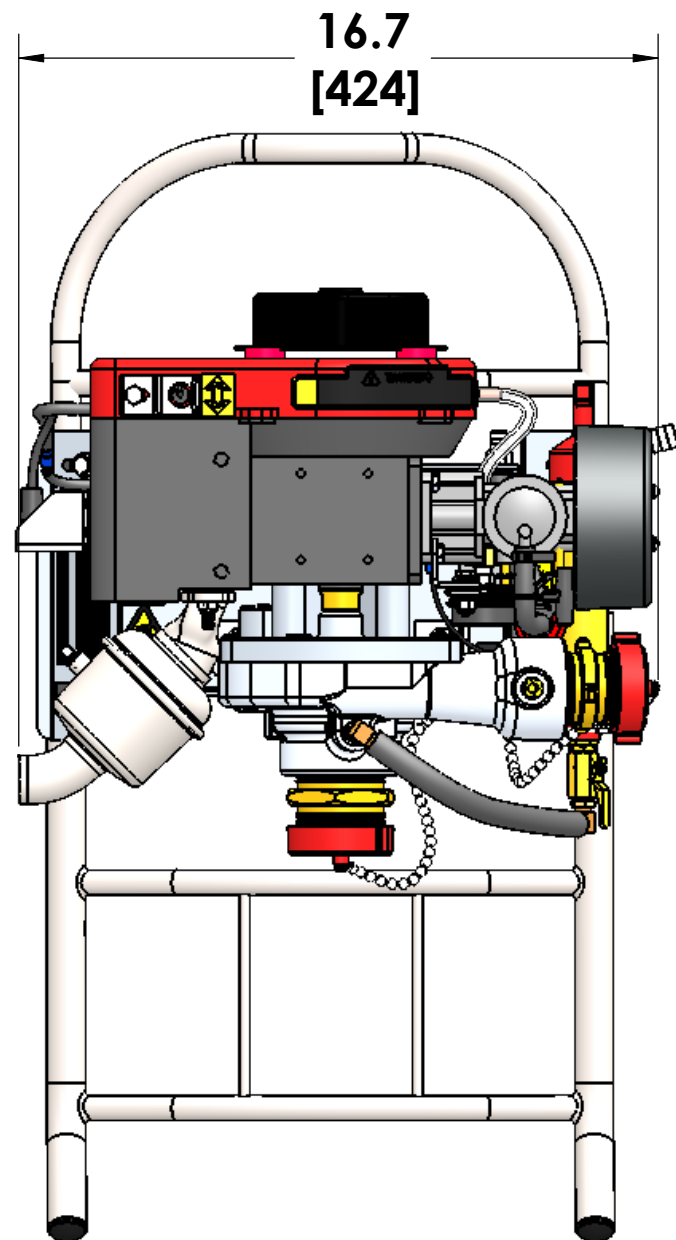

16.7  
[424]

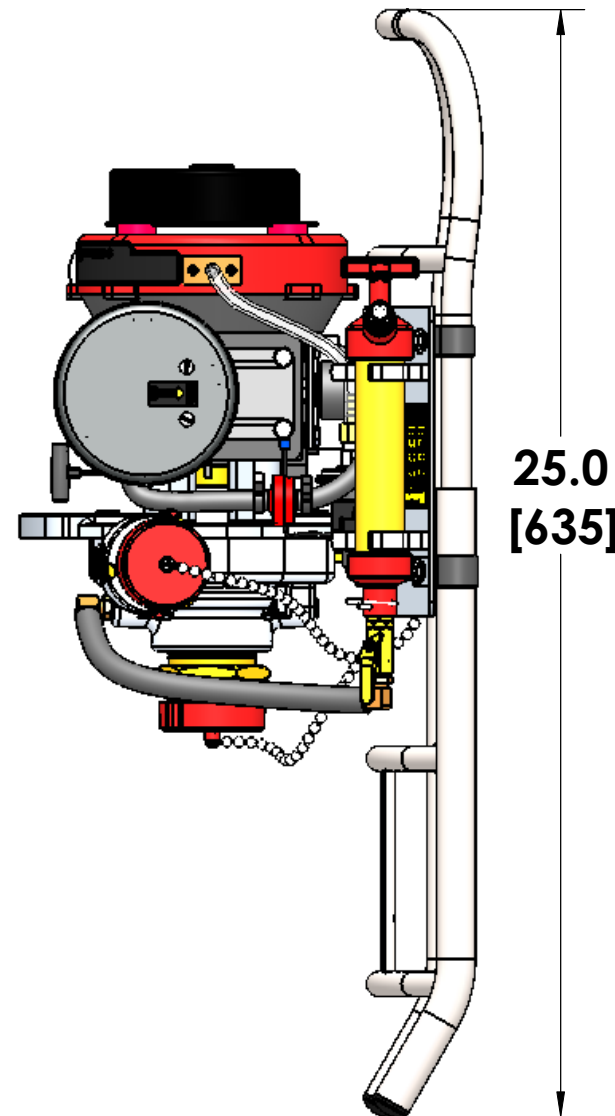

25.0  
[635]

## FEATURES:

- PADDED ADJUSTABLE FRAME
- SINGLE STAGE CENTRIFUGAL PUMP
- HIGH SPEED 2-CYCLE ENGINE
- BRASS PISTON TYPE HAND PRIMING PUMP
- SELF-ADJUSTING MECHANICAL TYPE PUMP SEAL
- UP TO 220 PSI (15.2 bar) DISCHARGE PRESSURE
- FLOWS UP TO 75 GPM (285 lpm)
- OPTIONAL INTAKE AND DISCHARGE ADAPTOR SIZES
- OPTIONAL ACCESSORY KITS
- EMBER RESISTANT AIR FILTER
- MANUAL THROTTLE
- ENGINE OVER SPEED PROTECTION

NOTE: [###] = mm

THIRD ANGLE PROJECTION 			A unit of 		607 N.W. 27th Ave. Ocala, Florida 34475 Phone: 352-629-5020 FAX: 352-629-2902	
	<b>FYR-PAK UNIT</b> <b>PRODUCT DRAWING</b>					
This document and the information hereon are the exclusive property of Class 1 and is loaned to you subject to return on demand, unless otherwise agreed to in writing by Class 1.	CAGE IDENT. NO.	COMPLETED 9/16/10	DRAWN JBS	CHECKED JBS	APPROVED JBS	PROJECT --
	SIZE <b>B</b>	DRAWING NUMBER				REV -
	SCALE 1:10	<b>CL1-PL-0049</b>				SHEET 1 OF 1